

USER GROUP: 6-23 Months, 2-5 Years, 5-12 Years
 RECOMMENDED CREW: 1 Person
 TOOLS REQUIRED:
 • Hammer / Mallet
 INSTALLATION TIME: 5 Minutes Per Timber
 WEIGHT: 20 lbs. Each
 CONCRETE REQUIRED: None

ITEM	Part No.	QTY	DESCRIPTION
1	LT-4	1	BLACK 4 ft x 12" Timber
2	LTH	1	30" Timber Stake

PRE-INSTALLATION CHECK:

Customer is responsible for verifying materials received by comparing received items with packing list. If any parts are missing or damaged, including documentation, contact your local sales representative immediately.

Supplier is not responsible for items discovered missing after 72 hours from time of delivery.

Before beginning installation, all installers must read and understand the Installation Introduction manual as supplied. If you did not receive a copy, or if you have any questions regarding any information in the Installation Instructions or this Installation Guideline, contact your local sales representative.

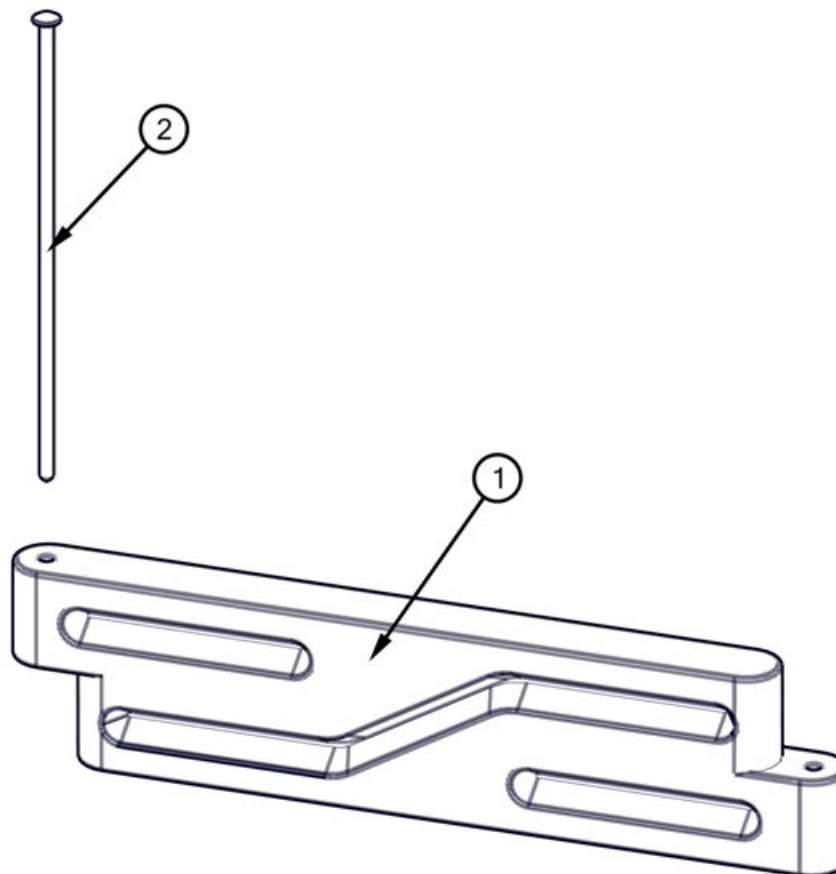

STEP 1

Lay out all timbers based upon site plan. Ensure ends of timbers fit together with holes aligned. Drive in stakes to temporarily hold timbers in place. Do not fully drive in spikes. Complete placing of all timbers. If timbers form a closed area, ensure last two timbers connect properly. Ensure required clearances for equipment is correct. Once timbers are set, complete driving in of stakes. Head of stake should be flush against top of timber. **DO NOT OVERDRIVE STAKES.** See Detail 1-1. Installation is complete.

Detail 1-1

