

Site Amenities

BY SUPERIOR RECREATIONAL PRODUCTS

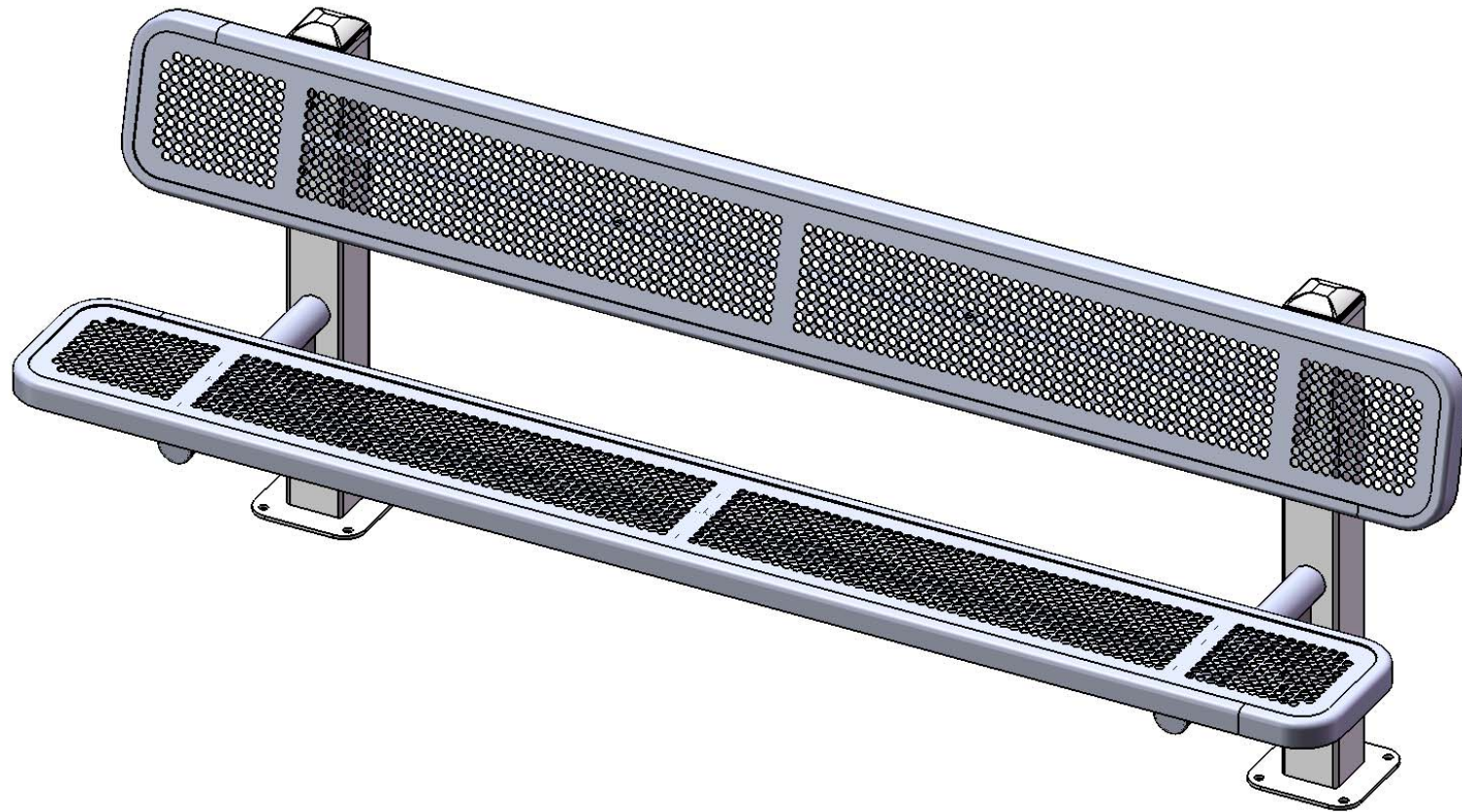

Model # B8WBINNVD4-4SM

HARDWARE

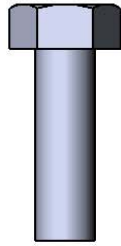

5/16" x 1"
Machine Bolt

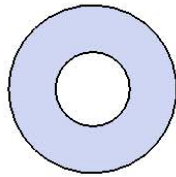

5/16" Washer

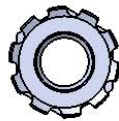

5/16" Washer

PRODUCT SPECIFICATIONS

B8WBINNVD4-4SM SINGLE SIDED SURFACE MOUNT BENCH WITH BACK

Seat & Back: 11 gauge die formed angle frame 1"x1-7/8" with 3" radius corners. 12 ga. sheet steel is punched with 5/8" diameter holes to create the perforated pattern. 7 gauge x 1-1/2" flat bar center support and mounting bracket understructure. Electrically MIG welded.

Coating: Oven fused functionalized polyethylene copolymer-based thermoplastic. Fluidized bed coating application with superior mechanical performance, impact resistance and UV-stability.

Frame: The main post is fabricated from 4 x 4 x 11 gauge square tubing. 2-3/8" O.D. x 12 gauge pre-galvanized structural steel tubing seat support. Seat arms are supported by a 1/4" thick, 6" gusset. Tube ends are pre-galvanized steel capped. Seat and back mounting points are 7 gauge x 1-1/2" die stamped steel flat bar. All electrically MIG welded.

Frame Coating: Electrostatic powder coated application oven cured.

Hardware: All stainless steel hardware fasteners.

Dimensions: 8' bench surface mount with back. Seat and back are 12" wide x 96" long. Seat height is 18-1/2". Seat back height is 35-1/2". Total depth of seat with back is 25".

COMPONENTS

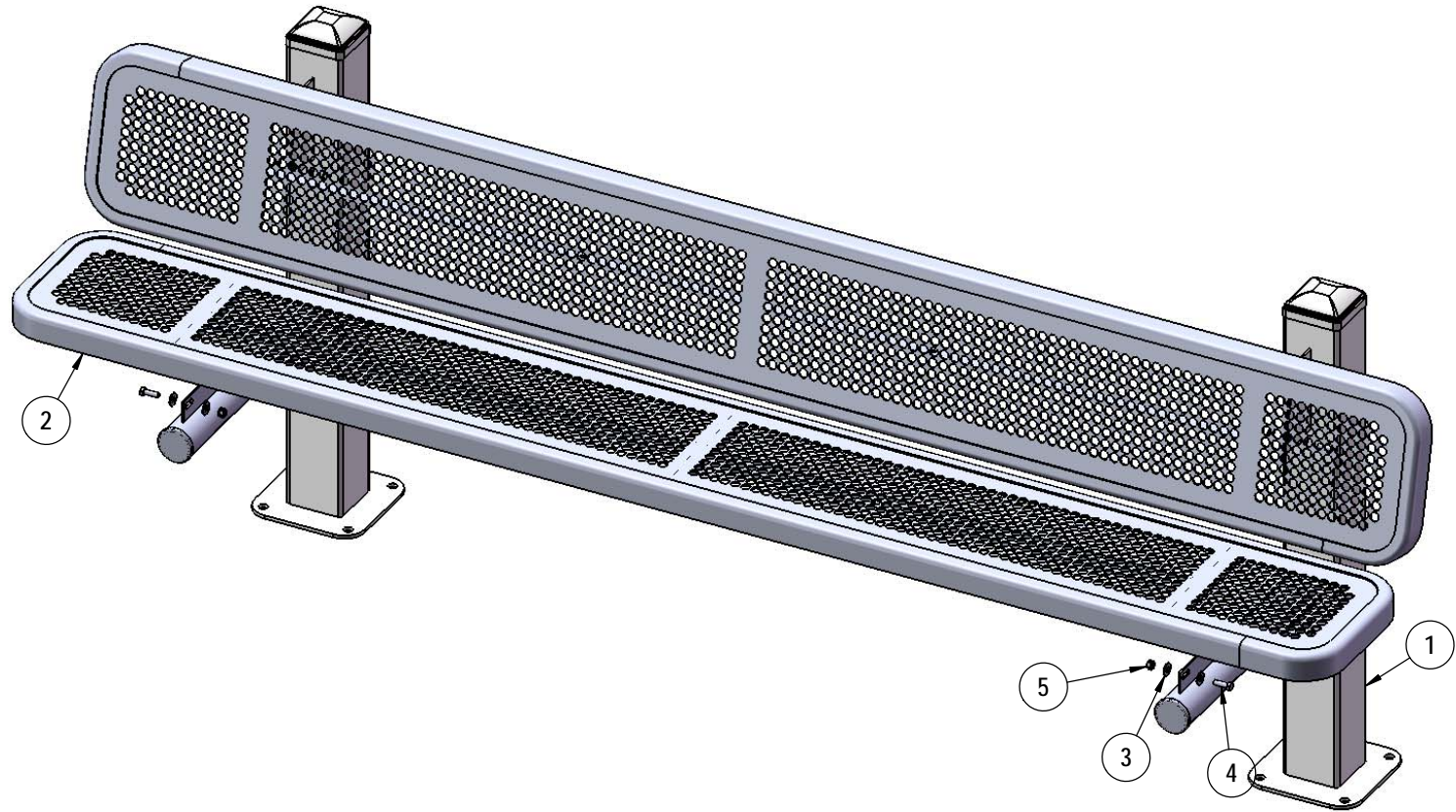

ITEM NO.	PartNo	DESCRIPTION	QTY.
1	P-V961SM	961 Vinyl Surface Mount Leg	2
2	T-P96-S	8' Punched Seat	2
3	33-02-0007	5/16" SS Washer	16
4	33-05-0029	5/16" x 1" Machine Bolt (SS)	8
5	33-03-0012	5/16" Kep Nut (SS)	8

Optional Surface Mount Hardware:
 3/8" x 3-1/2" Concrete Expansion Anchor Bolts
 (Not Included)



STEP 1

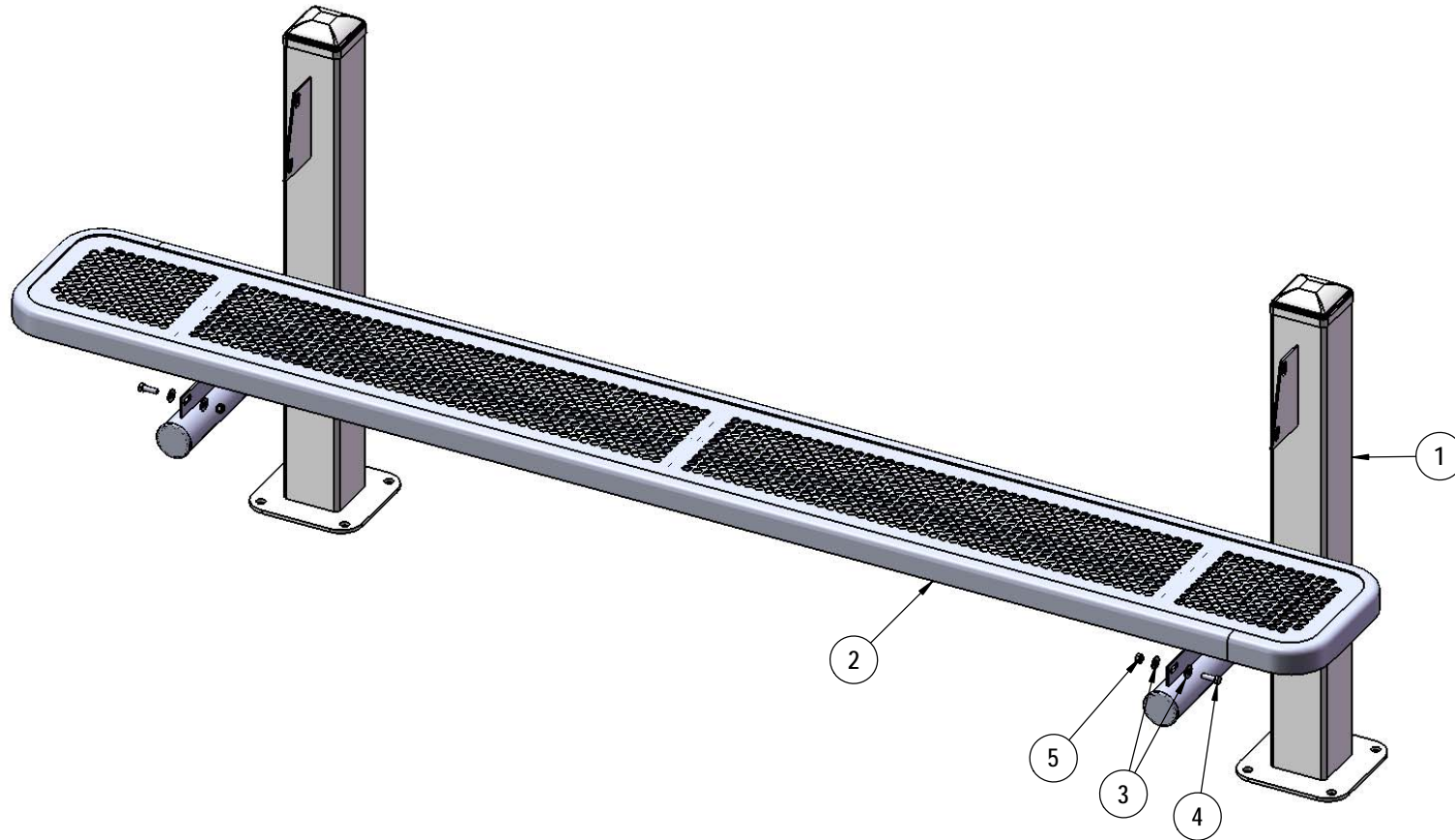

Attach the 8' Seat to the Legs using specified hardware.

STEP 2

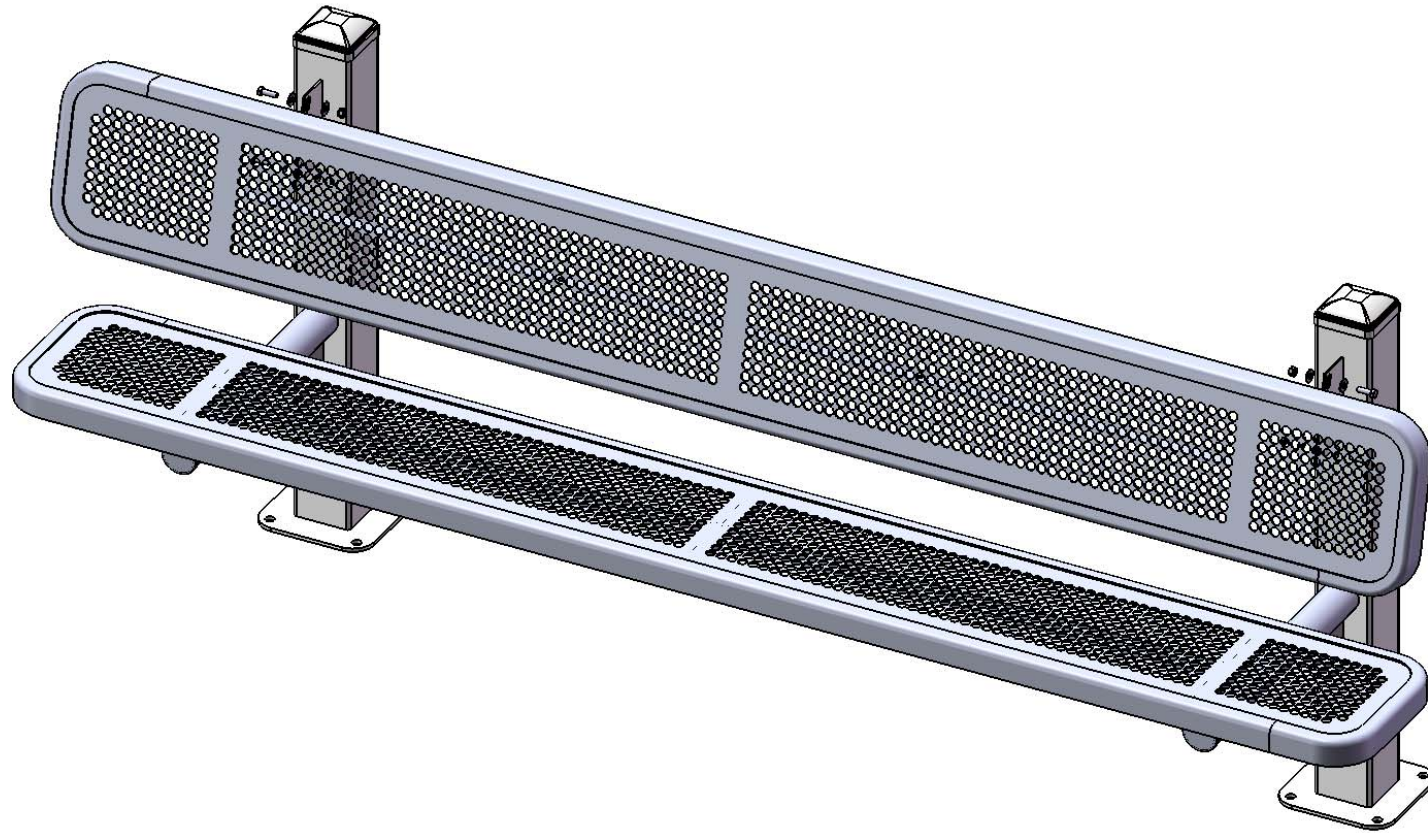

Repeat Step 1 for the back.

OVERALL DIMENSIONS

