

# Site Amenities

BY SUPERIOR RECREATIONAL PRODUCTS

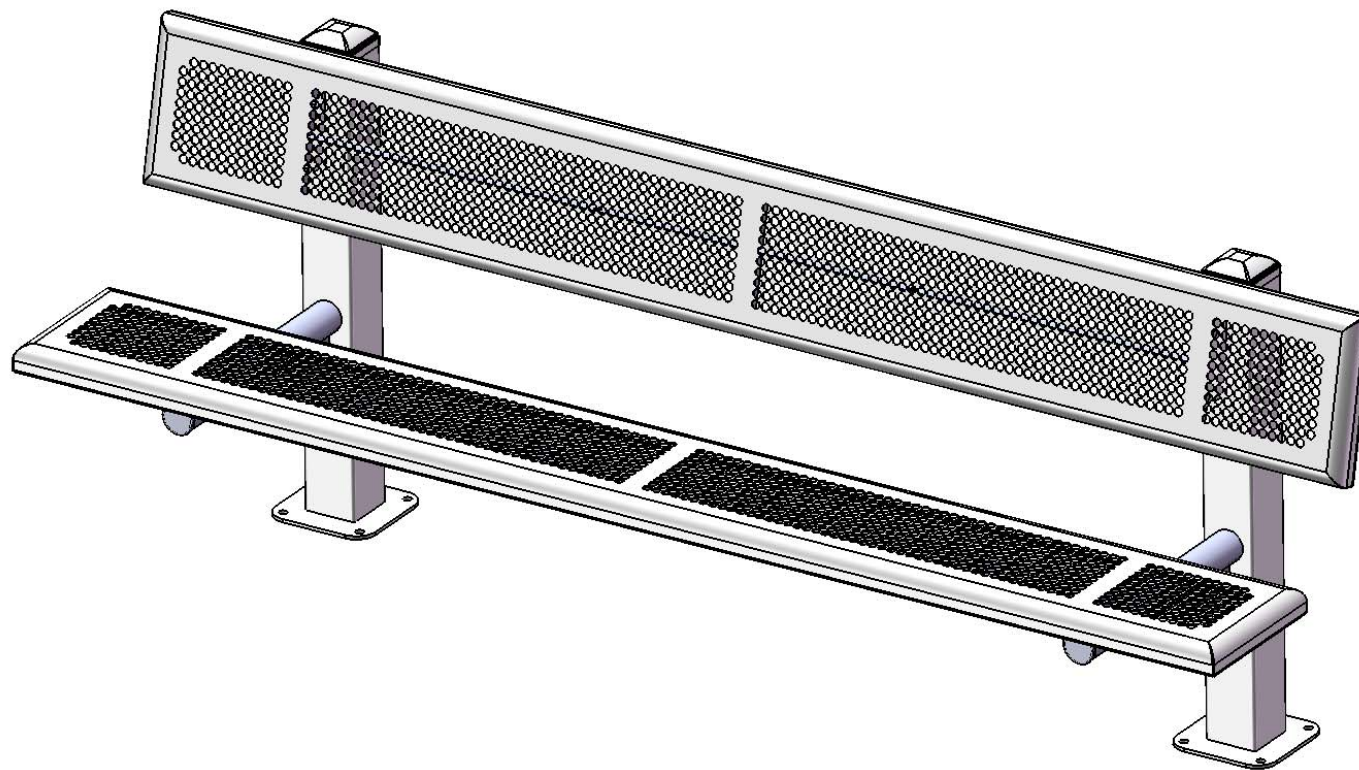

Model # B8WBPERFD4-4SM

 **SUPERIOR**<sup>®</sup>  
RECREATIONAL PRODUCTS  
A **PLAYCORE** Company

# HARDWARE

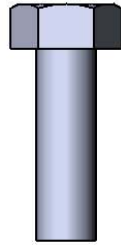

5/16" x 1"  
Machine Bolt

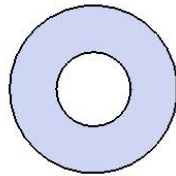

5/16" Washer

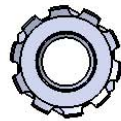

5/16" Kep Nut

# PRODUCT SPECIFICATIONS

## **B8WBPERFD4-4SM SINGLE SIDED SURFACE MOUNT BENCH WITH BACK**

**Seats & Back:** Seats shall have a 1 ½" radius edge, fabricated from a 14 ga. plate. Holes are precision punched at 5/8" diameter. 7 gauge x 1-1/2" flat bar center support and mounting bracket understructure. Electrically MIG welded.

**Coating:** Oven fused functionalized polyethylene copolymer-based thermoplastic. Fluidized bed coating application with superior mechanical performance, impact resistance and UV-stability.

**Frame:** The main post is fabricated from 4 x 4 x 11 gauge square tubing. 2-3/8" O.D. x 12 gauge pre-galvanized structural steel tubing seat support. Seat arms are supported by a 1/4" thick, 6" gusset. Tube ends are pre-galvanized steel capped. Seat and back mounting points are 7 gauge x 1-1/2" die stamped steel flat bar. All electrically MIG welded.

**Frame Coating:** Electrostatic powder coated application oven cured.

**Hardware:** All stainless steel hardware fasteners.

**Dimensions:** 8' bench surface mount with back. Seat and back are 12-1/8" wide x 96-1/8" long. Seat height is 18". Seat back height is 36". Total depth of seat with back is 25".

# COMPONENTS

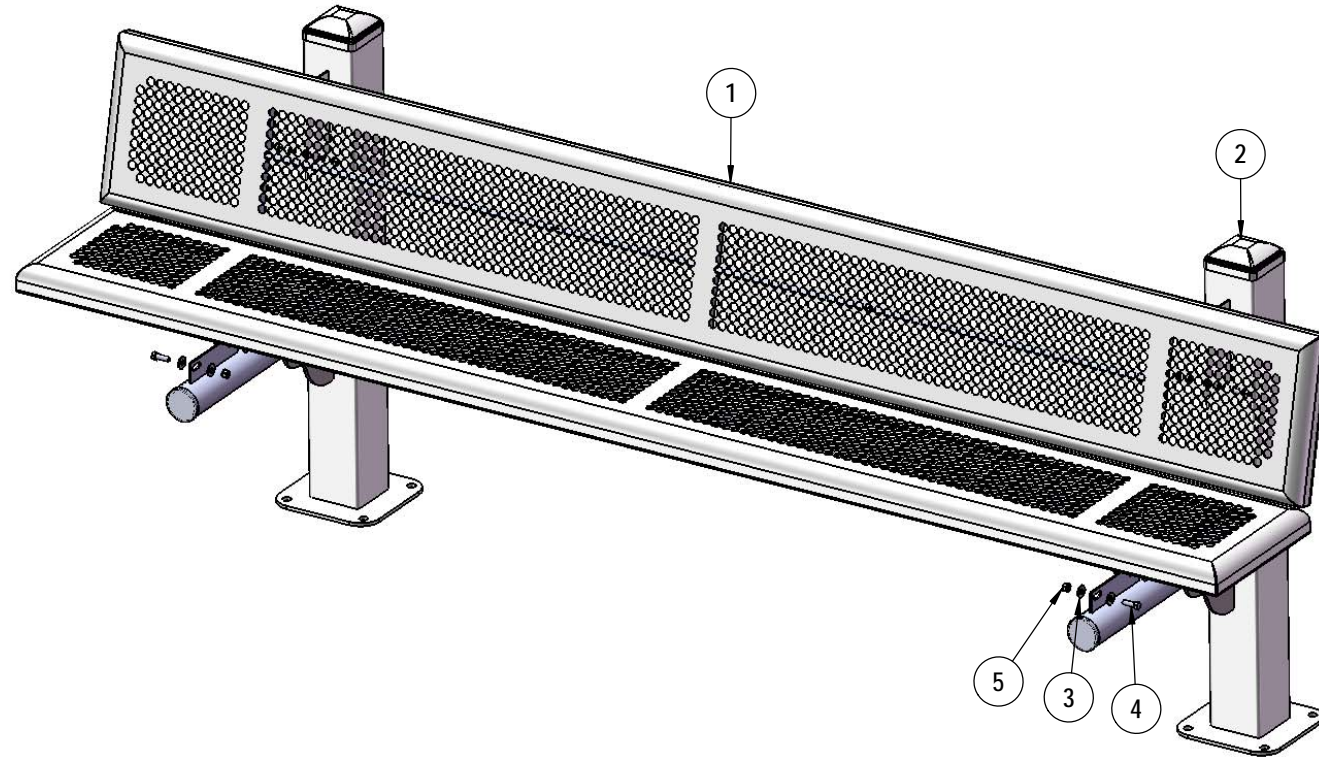

ITEM NO.	PartNo	DESCRIPTION	QTY.
1	T-PR96-S	8' Punched Rolled Seat	2
2	P-V961SM	961 Vinyl Surface Mount Leg	2
3	33-02-0007	5/16" SS Washer	16
4	33-05-0029	5/16" x 1" Machine Bolt (SS)	8
5	33-03-0012	5/16" Kee Nut (SS)	8

Optional Surface Mount Hardware:  
 3/8" x 3-1/2" Concrete Expansion Anchor Bolts  
 (Not Included)



# STEP 1

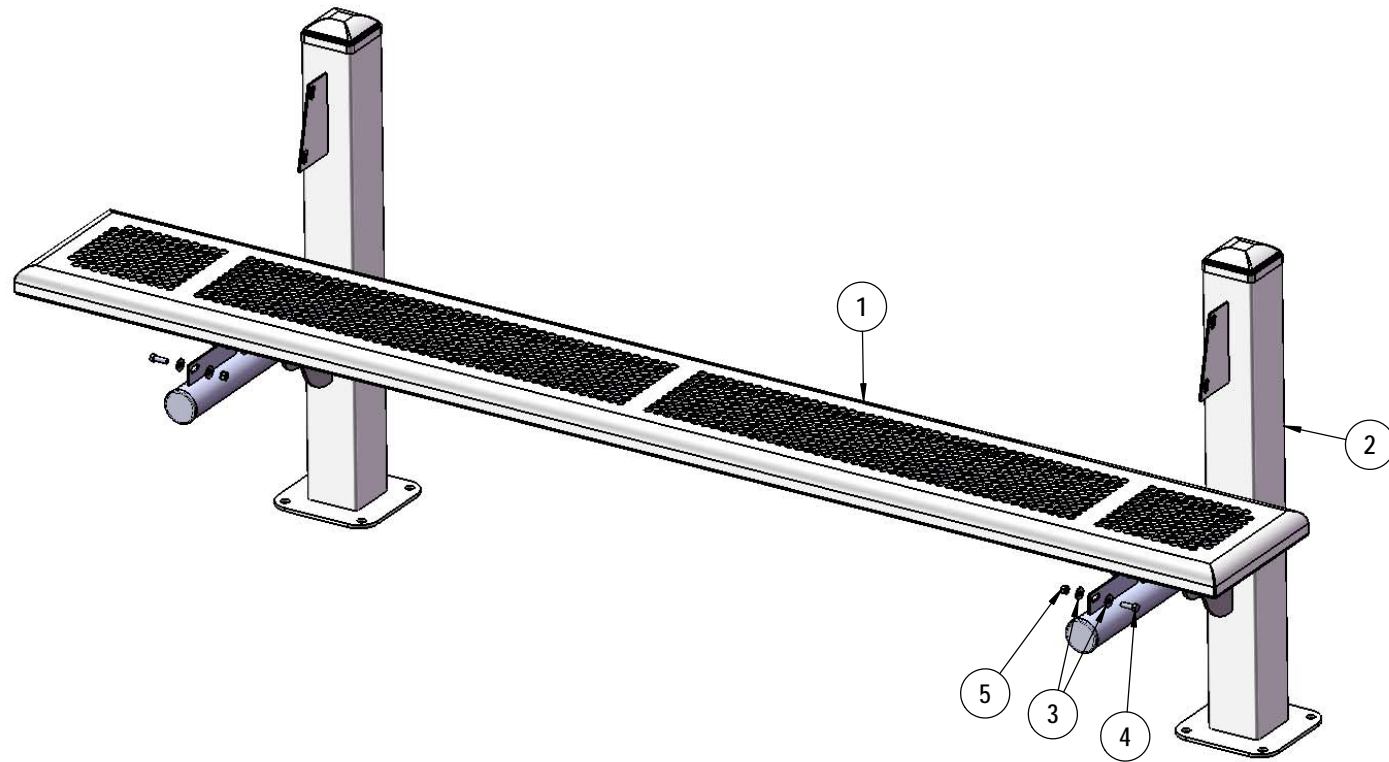

Attach the 8' Seat to the Legs using specified hardware.

## STEP 2

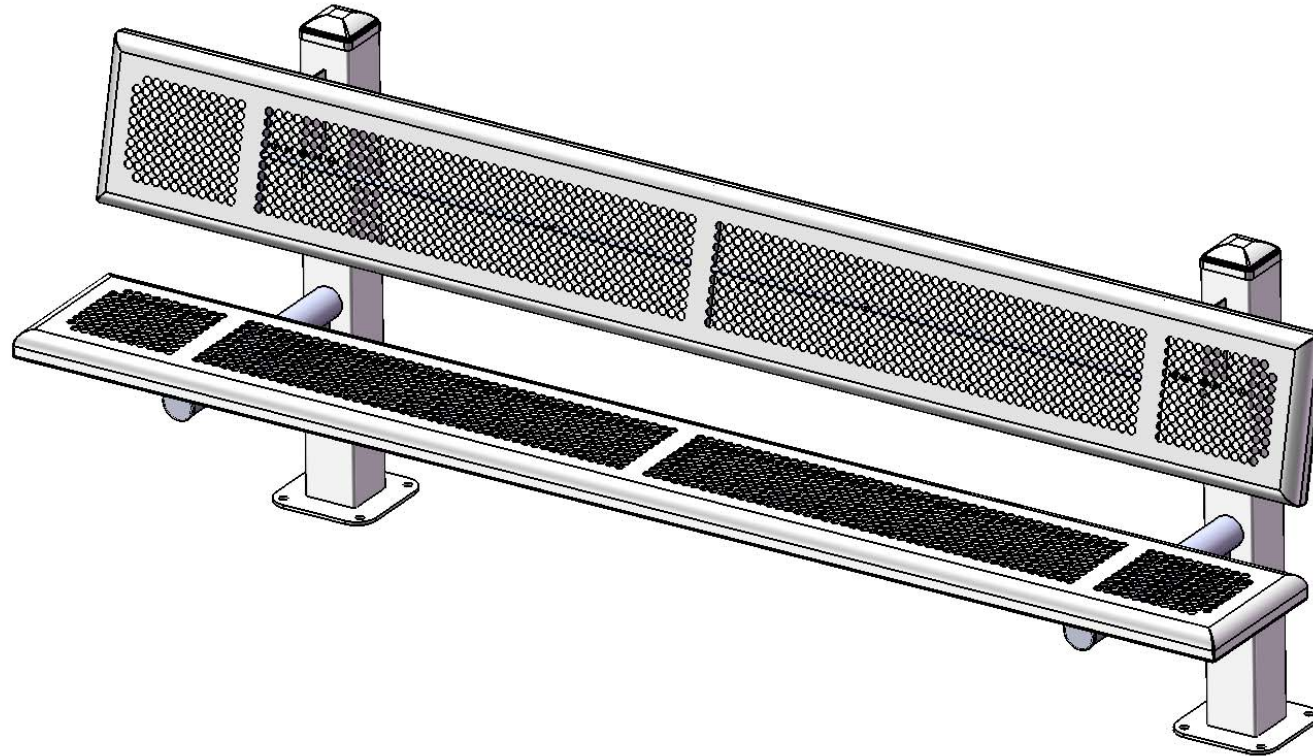

Repeat Step 1 for the back.



# OVERALL DIMENSIONS

