

# Site Amenities

BY SUPERIOR RECREATIONAL PRODUCTS

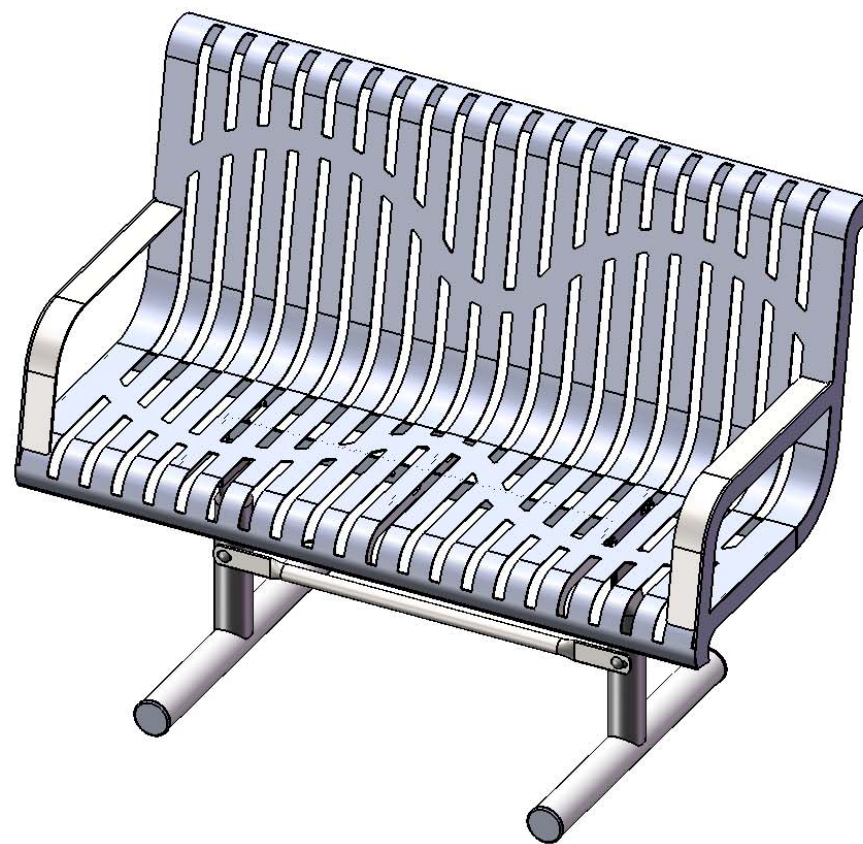

Model #  
B4WBCLASSICWINGLINEP

 **SUPERIOR**<sup>®</sup>  
RECREATIONAL PRODUCTS  
A **PLAYCORE** Company

# PRODUCT SPECIFICATIONS

## **B4WBCLASSICWINGLINEP PORTABLE CONTOURED BENCH WITH BACK**

Seats: 12 gauge die formed flat steel plate with laser cut design. End plates are made of 10 gauge flat steel plate. Reinforced with 3/16 x 1-1/2" flat strip. Armrest are made from 7ga steel plate. Electrically MIG welded.

Coating: Oven fused functionalized polyethylene copolymer-based thermoplastic. Fluidized bed coating application with superior mechanical performance, impact resistance and UV-stability.

Frame: Legs are 2-3/8" O.D. x 12 gauge pre-galvanized structural steel tubing. Tube ends are pre-galvanized steel capped. Seat mounting points are 10 gauge x 1-1/2" die stamped steel flat bar. All electrically MIG welded.

Frame Coating: Electrostatic powder coated application oven cured.

Hardware: All hardware shall be stainless steel.

Dimensions: 4' portable bench with back. Seats are 17-3/4" wide x 48-3/8" long. Seat height is 18-1/8" from the ground to the top of the seat. The overall dimensions are 48" x 24-3/4" x 37-5/16" ..

# COMPONENTS

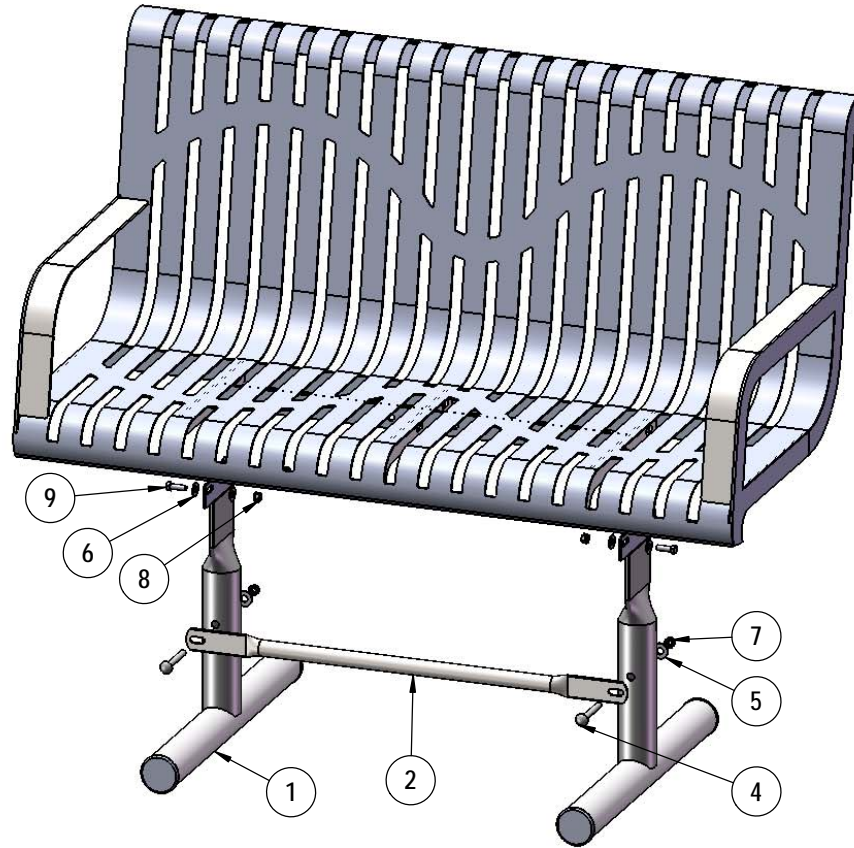

ITEM NO.	PartNo	DESCRIPTION	QTY
1	P-V942P	942P Vinyl Leg	2
2	P-04-04-0018	29 1/2" brace	1
3	T-01-01-0931	963 4' Classic Modern Seat	1
4	33-06-0058	3/8" x 3" Carriage Bolt (SS)	2
5	33-02-0008	3/8" Flat Washer (SS)	2
6	33-02-0007	5/16" SS Washer	8
7	33-03-0013	3/8" Kep Nut (SS)	2
8	33-03-0012	5/16" Kep Nut (SS)	4
9	33-05-0029	5/16" x 1" Machine Bolt (SS)	4

# STEP 1

Attach the 4' Seat to the 942 Legs using specified hardware.

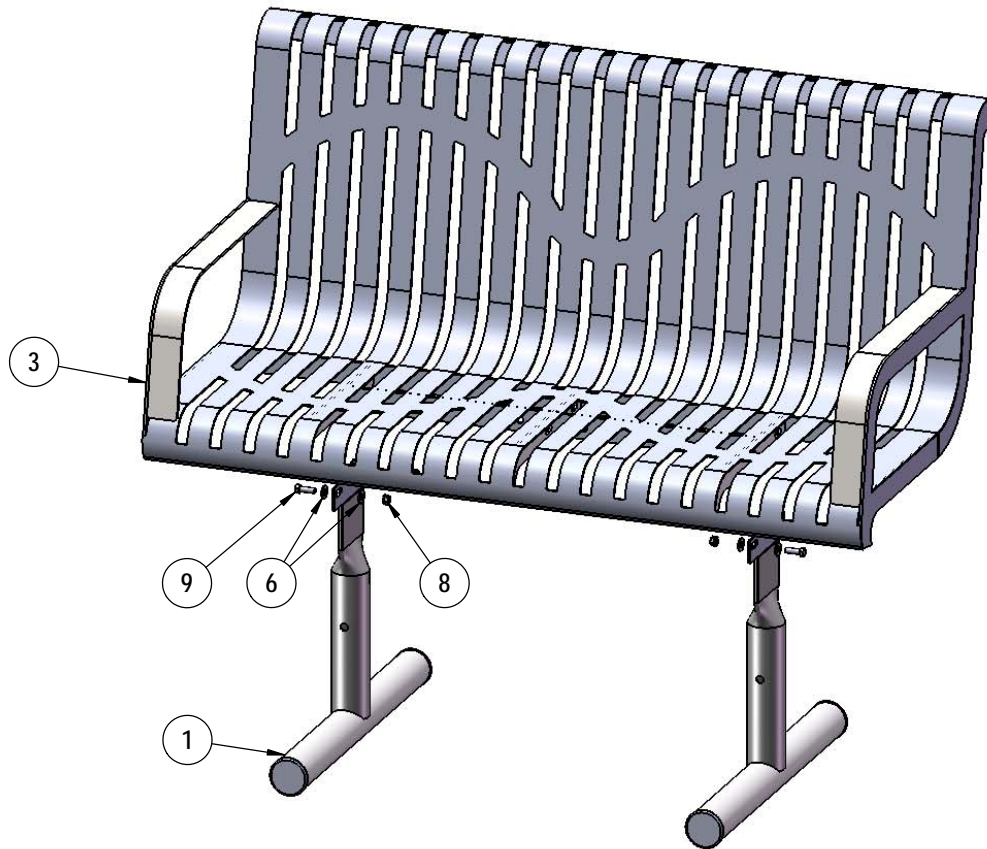

## STEP 2

Attach the 29-1/2" Brace to both legs using specified hardware.

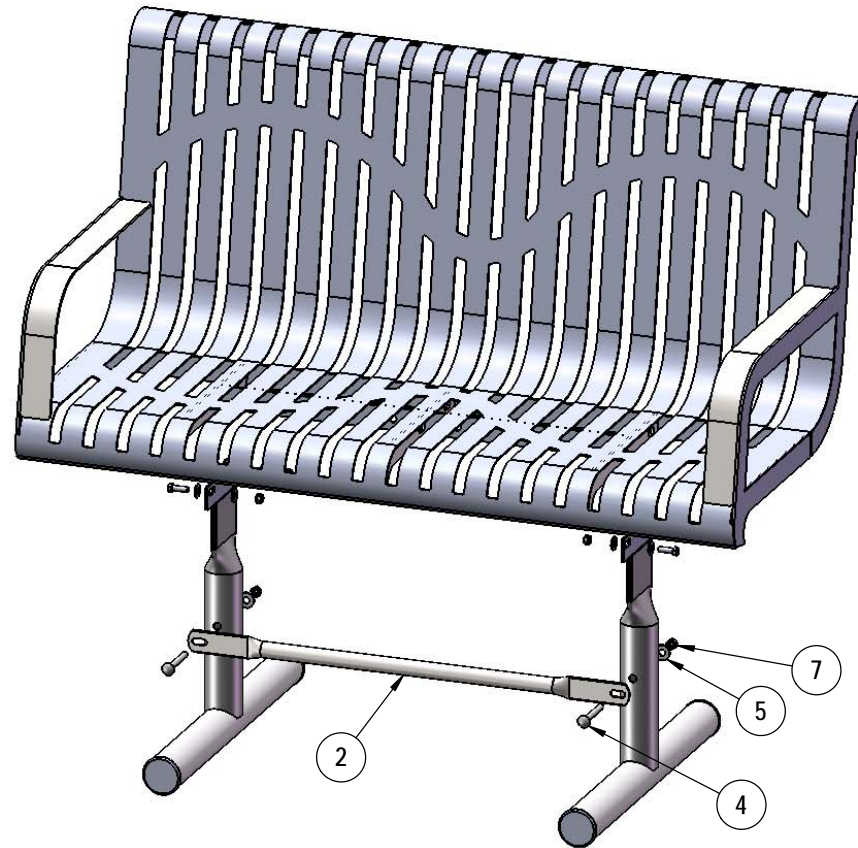

# OVERALL DIMENSIONS

