

# Site Amenities

BY SUPERIOR RECREATIONAL PRODUCTS

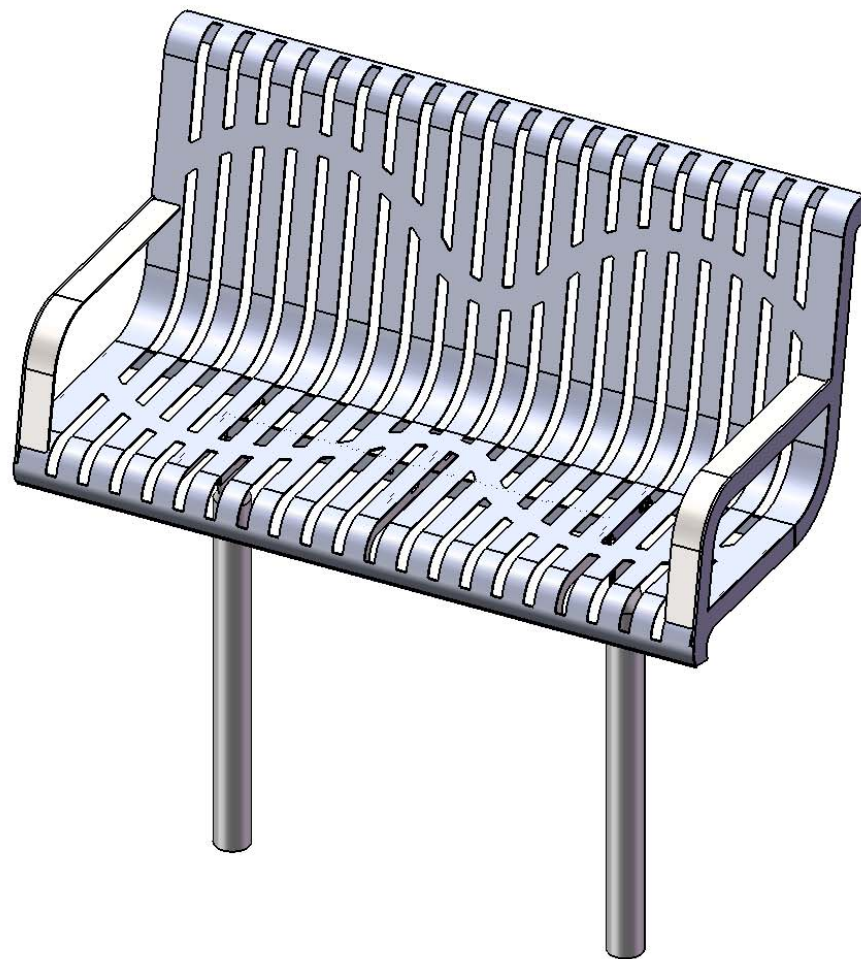

Model #  
B4WBCLASSICWINGLINES

 **SUPERIOR**<sup>®</sup>  
RECREATIONAL PRODUCTS  
A **PLAYCORE** Company

# PRODUCT SPECIFICATIONS

## **B4WBCLASSICWINGLINES INGROUND CONTOURED BENCH WITH BACK**

Seats: 12 gauge die formed flat steel plate with laser cut design. End plates are made of 10 gauge flat steel plate. Reinforced with 3/16 x 1-1/2" flat strip. Armrest are made from 7ga steel plate. Electrically MIG welded.

Coating: Oven fused functionalized polyethylene copolymer-based thermoplastic. Fluidized bed coating application with superior mechanical performance, impact resistance and UV-stability.

Frame: Legs are 2-3/8" O.D. x 12 gauge pre-galvanized structural steel tubing. Seat mounting points are 10 gauge x 1-1/2" die stamped steel flat bar. All electrically MIG welded.

Frame Coating: Electrostatic powder coated application oven cured.

Hardware: All hardware shall be stainless steel.

Dimensions: 4' inground bench with back. Seats are 17-3/4" wide x 43-5/8" long. Seat height is 18" from the ground to the top of the seat. The overall dimensions are 48" x 24-3/4" x 51-1/16".

# COMPONENTS

Attach the 4' Seat to the 942 Legs using specified hardware.

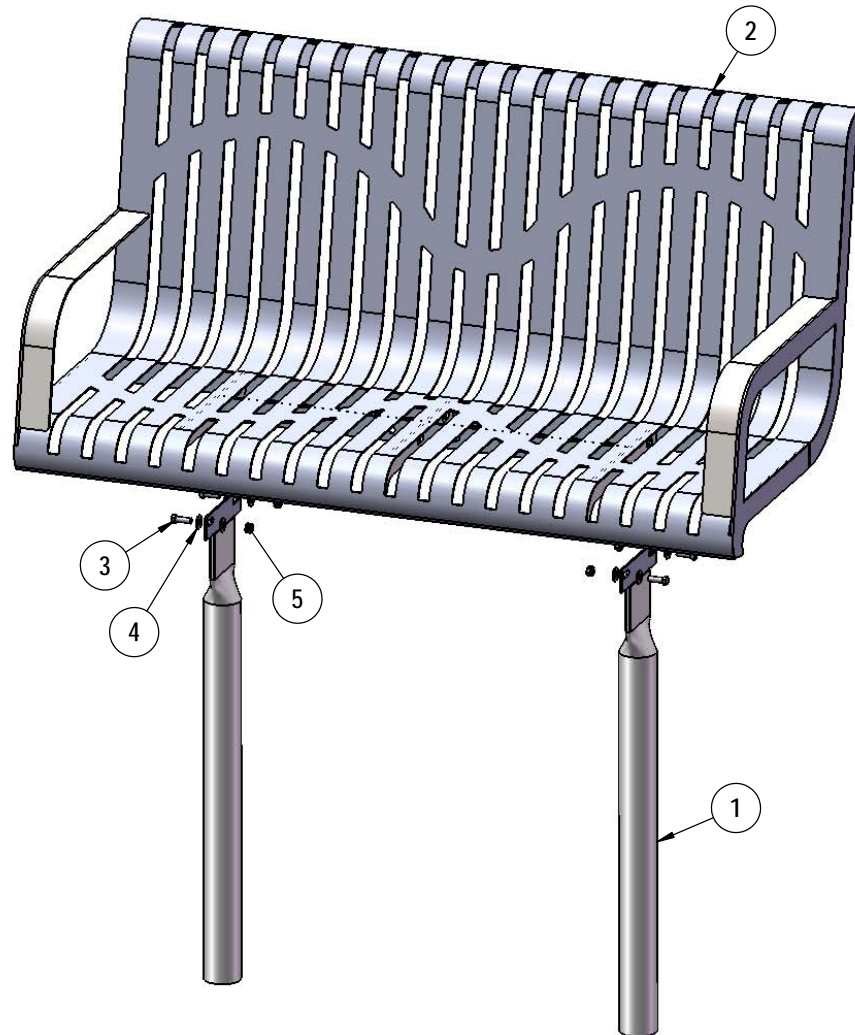

ITEM NO.	PartNo	DESCRIPTION	QTY
1	P-V942S	942S VINYL LEG	2
2	T-01-01-0931	963 4' Classic Modern Seat	1
3	33-05-0029	5/16" x 1" Machine Bolt (SS)	4
4	33-02-0007	5/16" SS Washer	8
5	33-03-0012	5/16" Kep Nut (SS)	4

# FOOTINGS

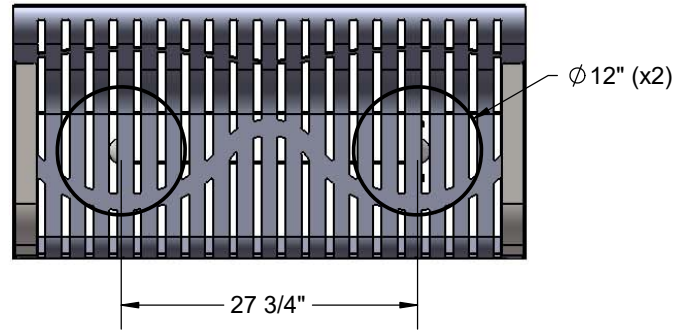

Estimated Required Concrete:  
11 - 50lb Bags of Concrete Mix

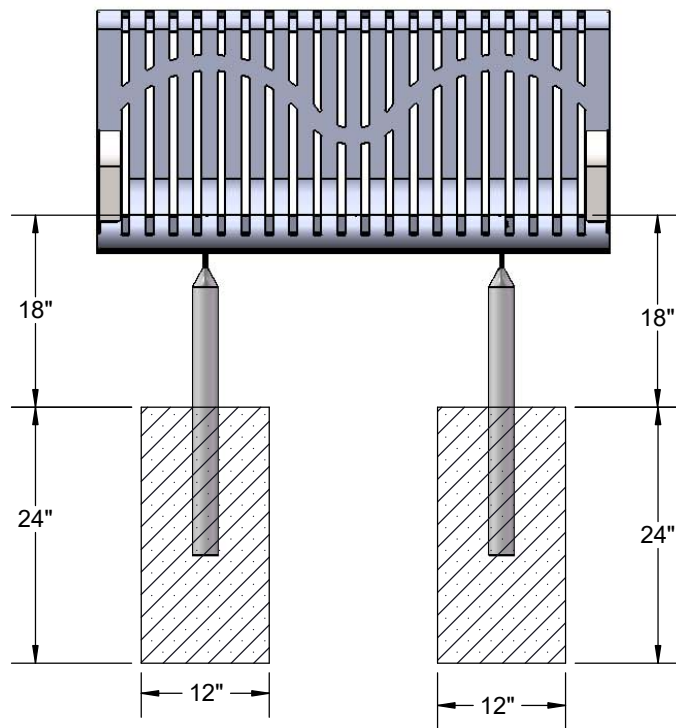

# OVERALL DIMENSIONS

