

# Site Amenities

BY SUPERIOR RECREATIONAL PRODUCTS



Model #  
B4WBGW-ST-V

 **SUPERIOR**<sup>®</sup>  
RECREATIONAL PRODUCTS  
A **PLAYCORE** Company

# HARDWARE

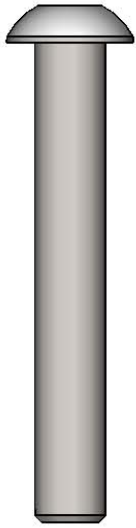

3/8" X 2-1/2"  
Button Head Bolt

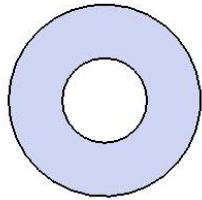

3/8" Washer

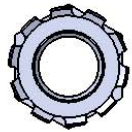

3/8" Kep Nut

## TOOLS REQUIRED

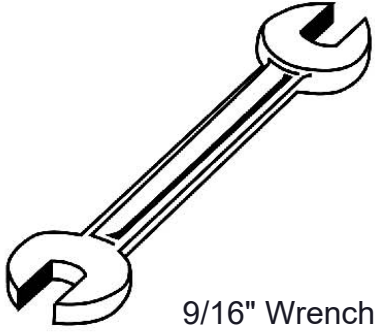

9/16" Wrench



9/16" Socket Wrench

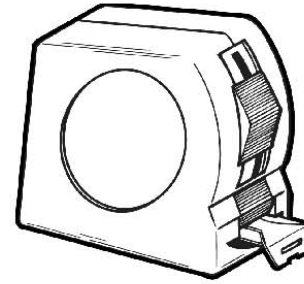

Tape Measure

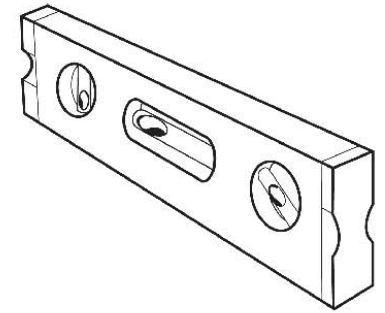

Level

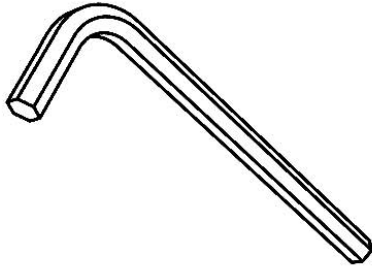

7/32 Allen Wrench

# PRODUCT SPECIFICATIONS

## **B4WBGW-ST-V GATEWAY SLAT BENCH WITH BACK**

Seats: Seats dimensions are 30" x 48". 12 gauge sheet steel is precision punched to create the slat pattern. End plates are made of 7 gauge flat steel plate. Reinforced with 3/16 x 1-1/2" flat strip. Electrically MIG welded.

Frame: Legs are cast aluminum.

Frame Coating: Metal is sandblasted to near white condition. Coated with zinc rich epoxy primer and top coated with electrostatic powdercoat, oven cured.

Hardware: All fasteners are stainless steel.

Dimensions: 4' portable/surface mount bench with back. Seats are 30" wide x 48" long. Seat height is 18-1/2" from the ground to the top of the seat. The overall dimensions are 30-1/4" x 51" x 37-1/2" tall.

# COMPONENTS

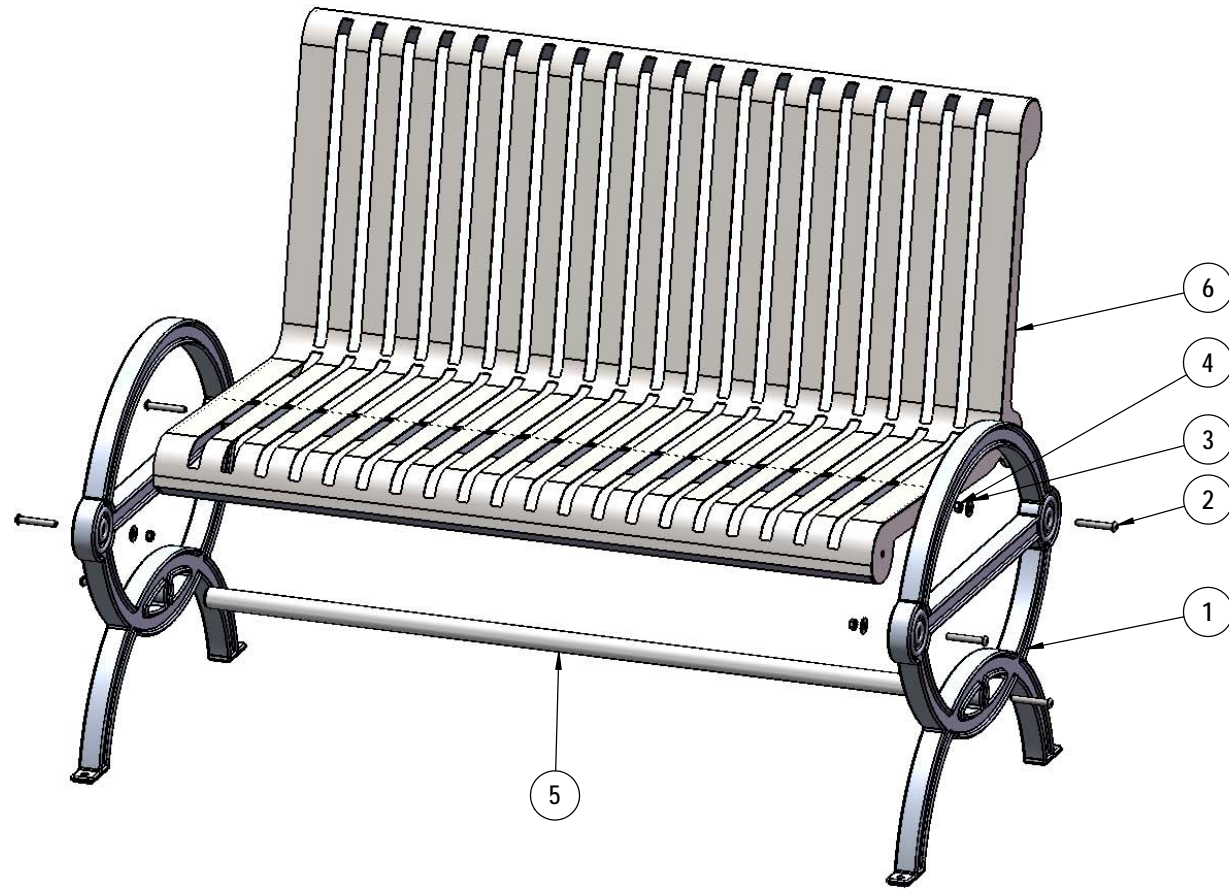

Optional Surface Mount Hardware:  
 3/8" x 3-1/2" Concrete Expansion Anchor Bolts  
 (Not Included)

ITEM NO.	PartNo	DESCRIPTION	QTY
1	11-01-CAST8	Durham Casted Aluminum Bench Frame	2
2	33-06-0093	3/8"-16 x 2-1/2" Button Head Bolt (SS)	6
3	33-02-0008	3/8" Flat Washer (SS)	4
4	33-03-0013	3/8" Kep Nut (SS)	4
5	01-01-0499	48" Support Bar	1
6	01-01-0641	4' Slat Durham w/back - Welded	1

# STEP 1

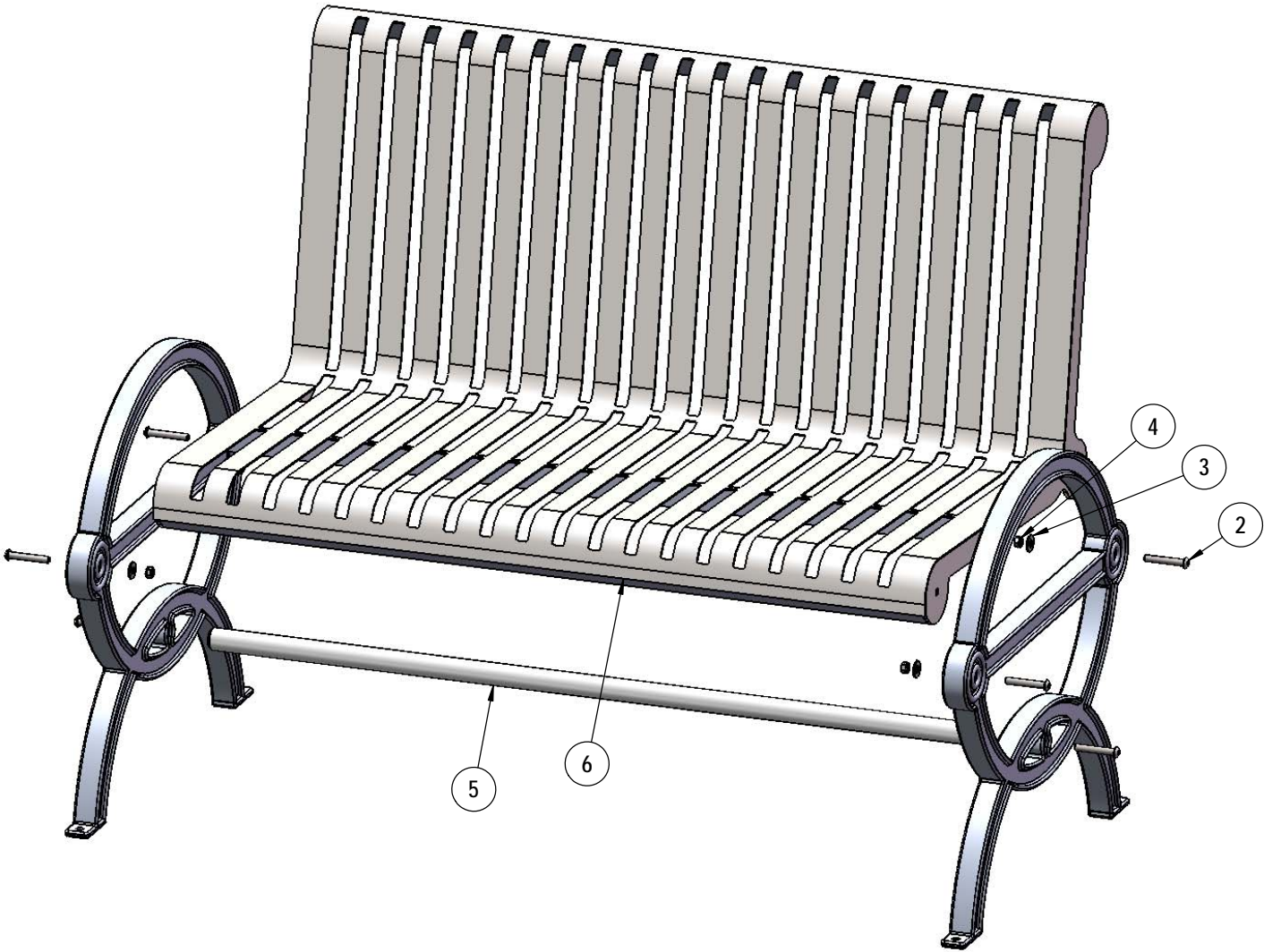

Attach the Seat and Support Bar to the Cast End Frames using the specified hardware.

# OVERALL DIMENSIONS

