

Site Amenities

BY SUPERIOR RECREATIONAL PRODUCTS

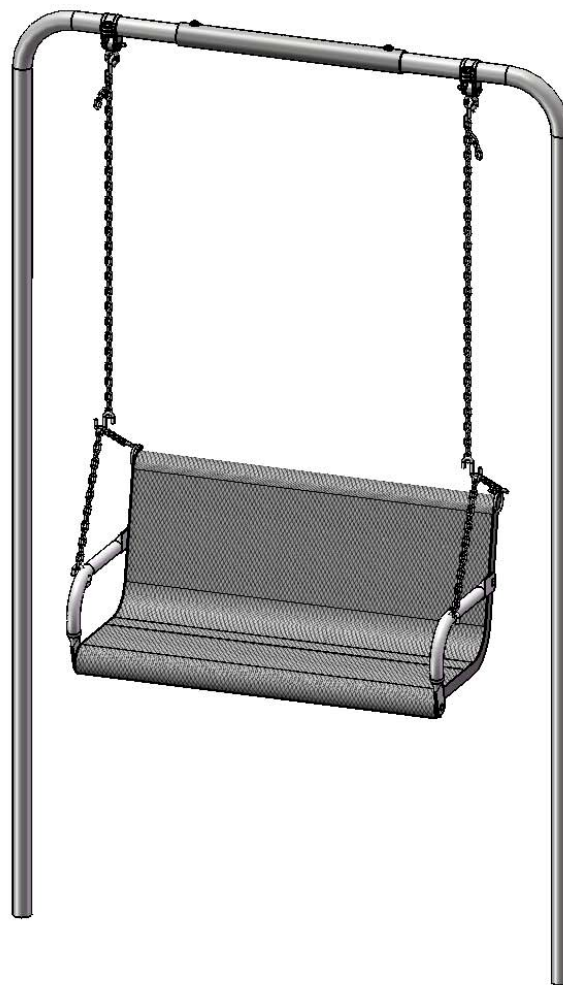

Model #B4WBMODSWING

HARDWARE



1/2" x 3/4"
Set Screw

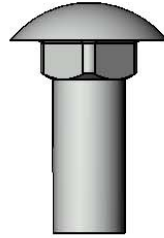

3/8" x 1"
Carriage Bolt

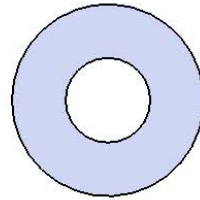

3/8" Flat Washer

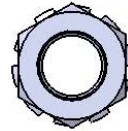

3/8" Kep Nut

USE ZONE

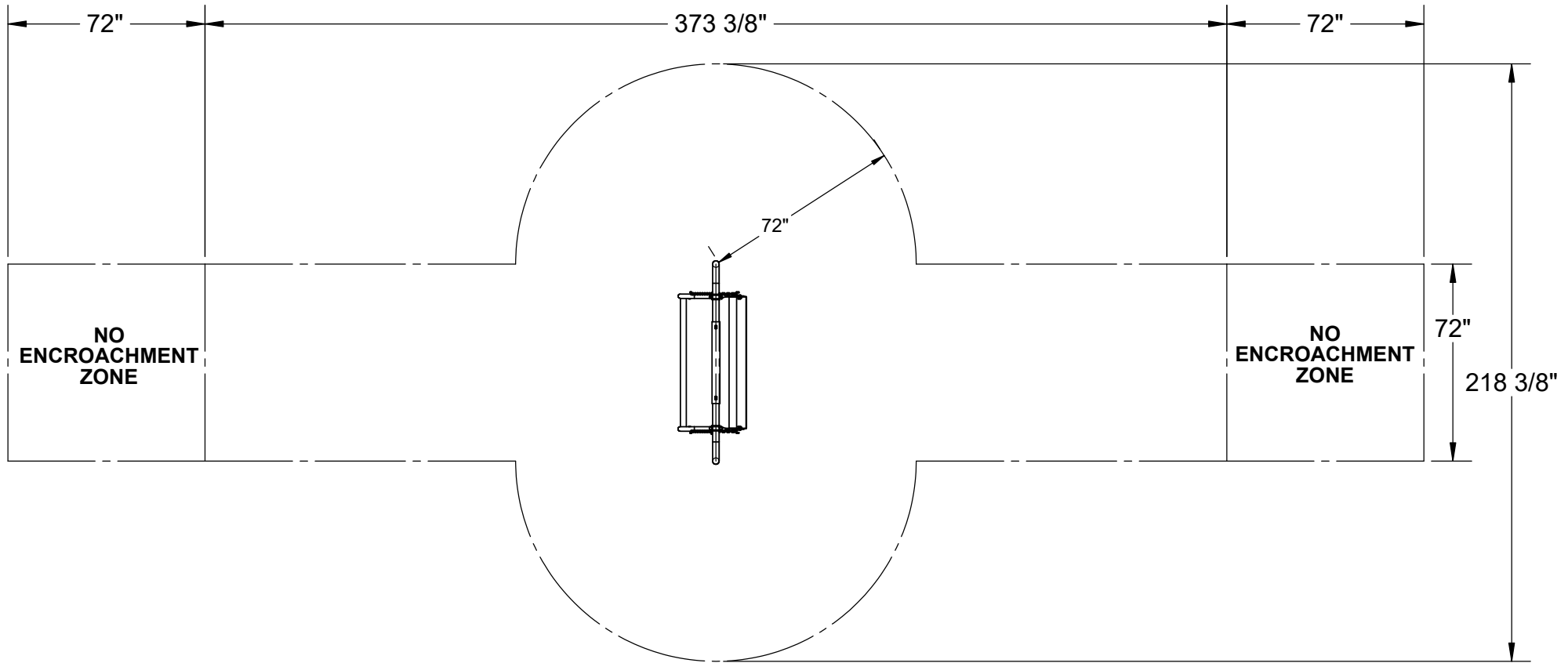

MINIMUM USE ZONE REQUIRED.

PRODUCT SPECIFICATIONS

B4WBMODSWING CONTOURED BENCH SWING WITH BACK, INGROUND

Seats: Seats dimensions are 24-3/4" x 15-1/8". 3/4" #9 steel expanded metal. End plates are made of 7 gauge flat steel plate. Reinforced with 3/16 x 1-1/2" flat strip. Electrically MIG welded.

Seat Coating: Oven fused functionalized polyethylene copolymer-based thermoplastic. Fluidized bed coating application with superior mechanical performance, impact resistance and UV-stability.

Frame: Legs are 2-3/8" O.D. x 10 gauge pre-galvanized structural steel tubing. Seat support is bent over a mandrel through the bend radius producing a wrinkle free bend. All electrically MIG welded. Galvanized Bearing hangers shall be malleable with oil impregnated bushings. Bench shall be suspended by a 4' chain.

Frame Coating: Electrostatic powder coated application oven cured.

Hardware: All stainless steel hardware fasteners.

Dimensions: 4' bench with back. Seats are 24-3/4" wide x 15-1/8" high. Seat height is 18" from the ground to the top of the seat.

Critical Fall Height: Fall height is 92-3/4" from the pivot point of the swing to the ground.

COMPONENTS

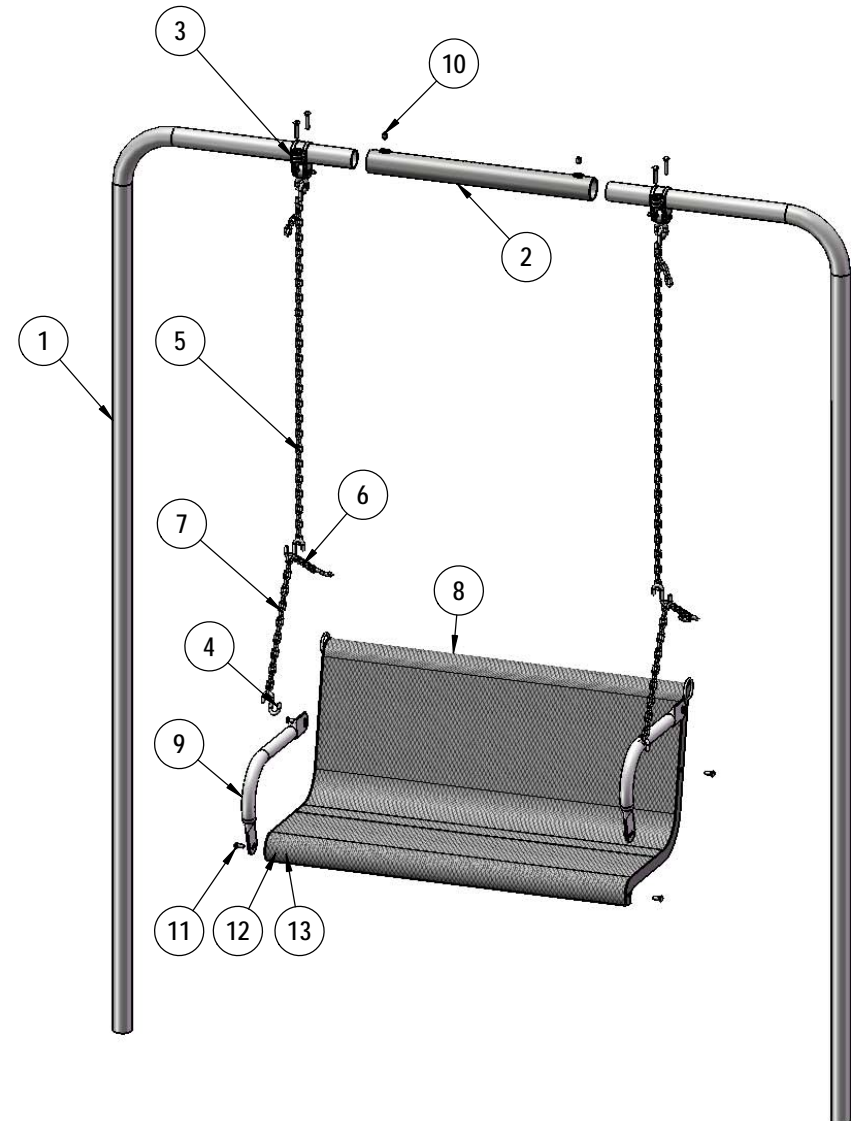

ITEM NO.	PartNo	DESCRIPTION	QTY.
1	V967-48	967 4' Leg	2
2	01-01-0183	967 Sleeve	1
3	55-SH-09	Swing Hanger For 2-38" OD	2
4	55-H155	S Hook	8
5	02-07-0205	49" Swing Chain	2
6	01-01-0190	967 11" Short Swing Chain	2
7	01-01-0191	967 19" Long Swing Chain	2
8	T-V48CT-967	4' Expanded Contour Seat	1
9	01-01-0185	967 Armrest - Welded	2
10	33-05-0009	1/2" x 3/4" set screw SS	2
11	33-06-0042	3/8" x 1" Carriage Bolt (SS)	4
12	33-02-0008	3/8" Flat Washer (SS)	4
13	33-03-0013	3/8" Kep Nut (SS)	4

STEP 1

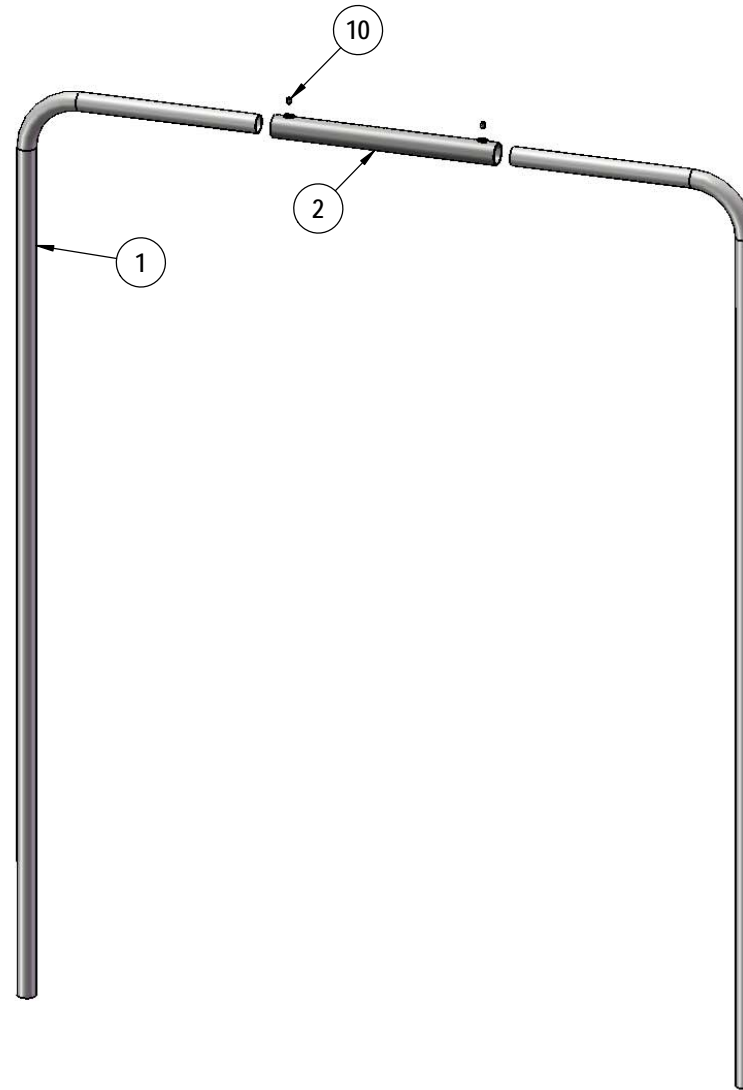

Before Footings are poured attach the 967 Sleeve to the 967 Legs using the specified hardware at the appropriate width. Tighten hardware till it is tight against the 967 leg.

FOOTINGS

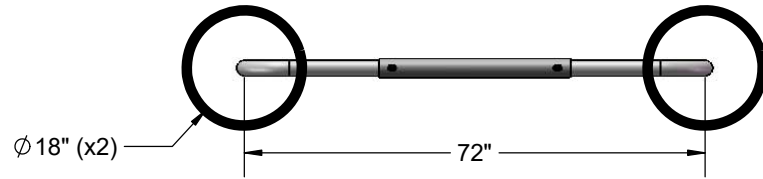

Estimated Required Concrete: 22 - 50lb. bags of Concrete

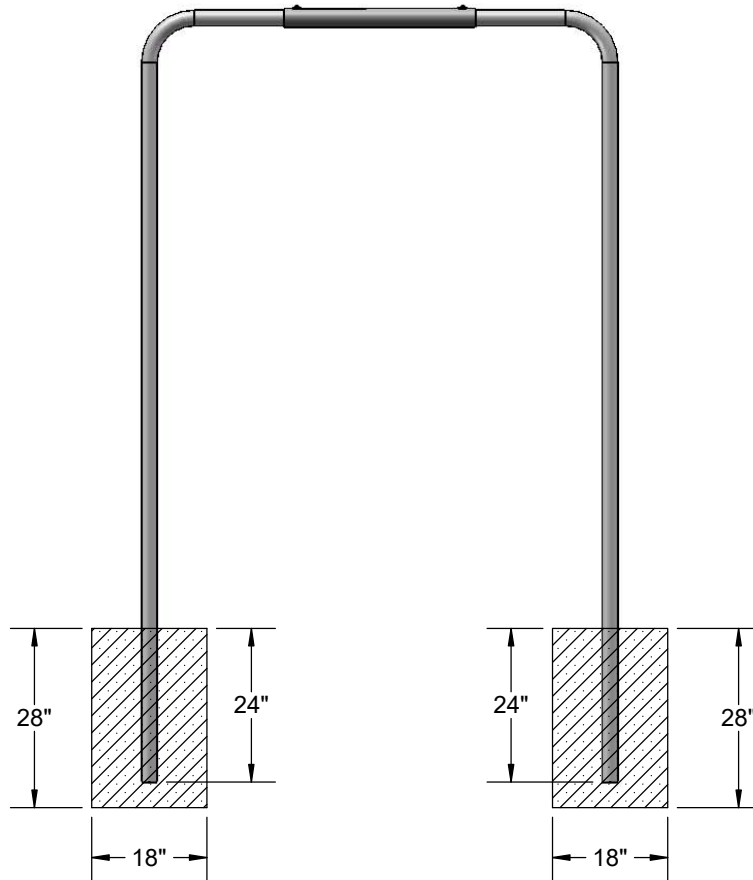

After Step 1 place 967 Legs into footings and pour the estimated amount of Concrete to fill footings. While curing continue to Step 2.

STEP 2

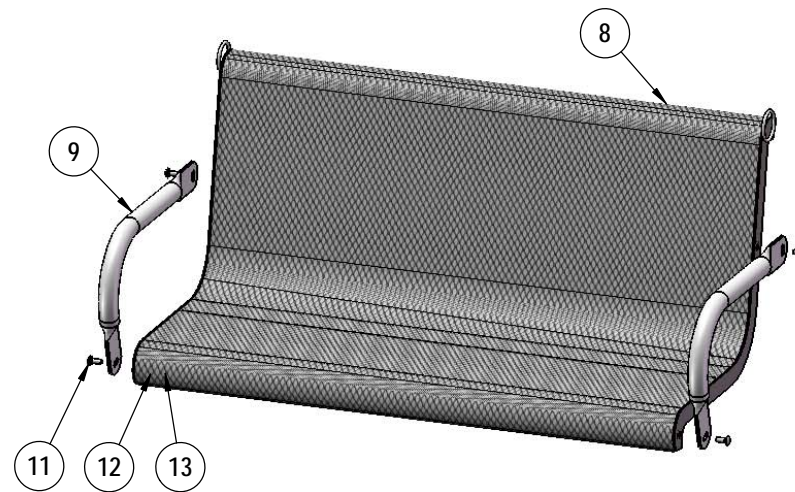

While waiting for Footings to cure attach the 967 Armrest to the 967 Bench using the specified hardware.

STEP 3

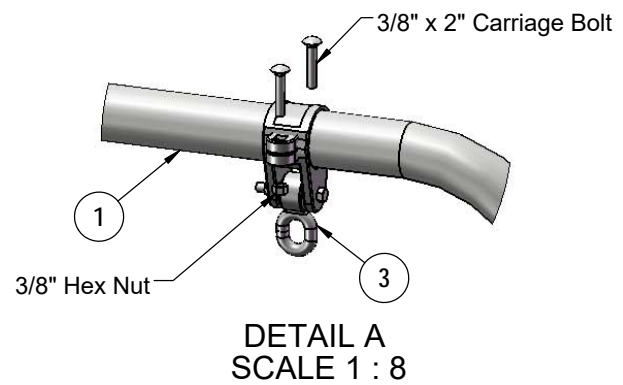
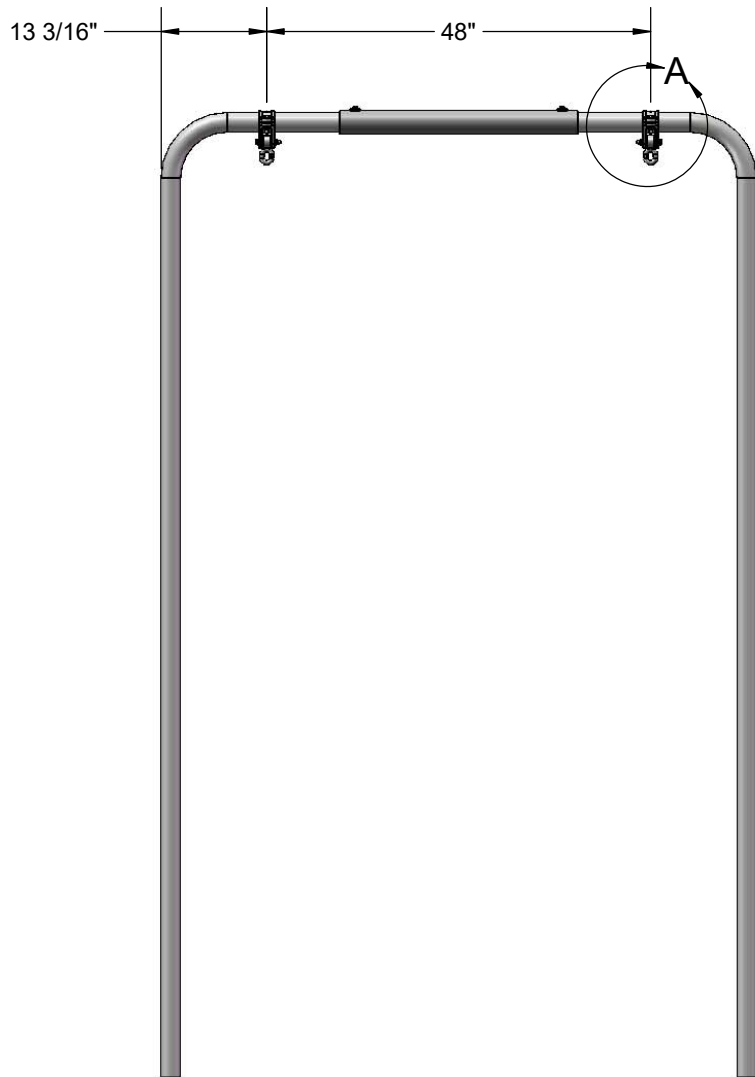

After Footings have cured attach the 2- Swing Hangers to the 967 Legs using the specified hardware. At the appropriate distance apart from each other.

STEP 4

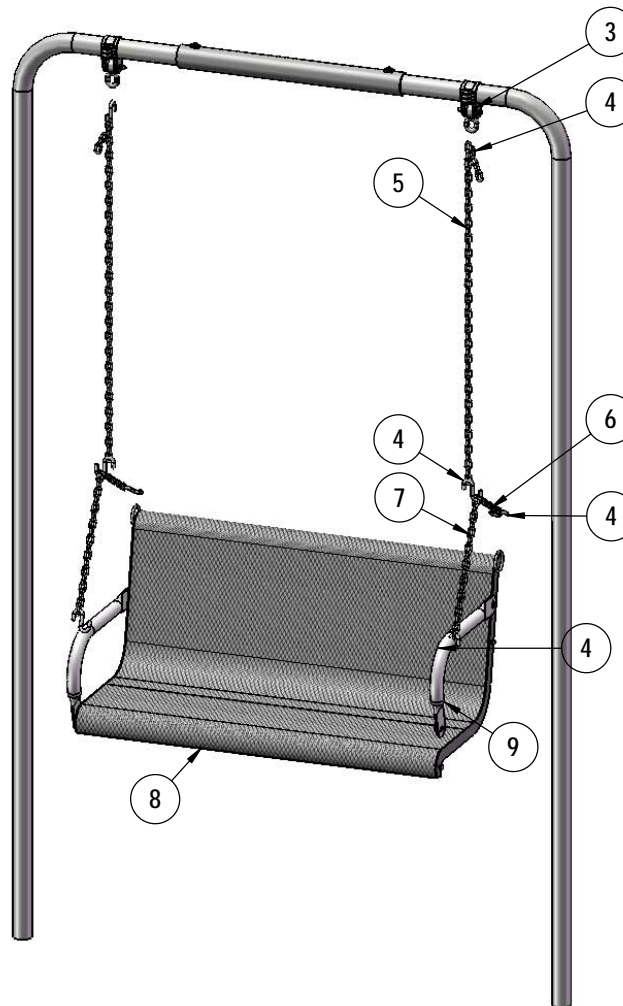

Attach the 967 11" and 19" Swing Chains to the 967 Bench using the S Hooks. S Hooks must hook through the loops on the 967 Bench and 967 Arms. Then attach the 11" Short Swing Chain to the 19" Long Swing Chain together using a S Hook. Next attach the 49" Swing Chain to the now attached S Hook that is attached to the 11" and 19" Swing Chains. Now on the other end of that 49" Swing Chain attach the final S Hooks to the Chain and then to the Swing Hanger at the desired length. We recommend where the top of the seat of the 967 Bench is approximately 18" from Ground Level.

OVERALL DIMENSIONS

