

Site Amenities

BY SUPERIOR RECREATIONAL PRODUCTS

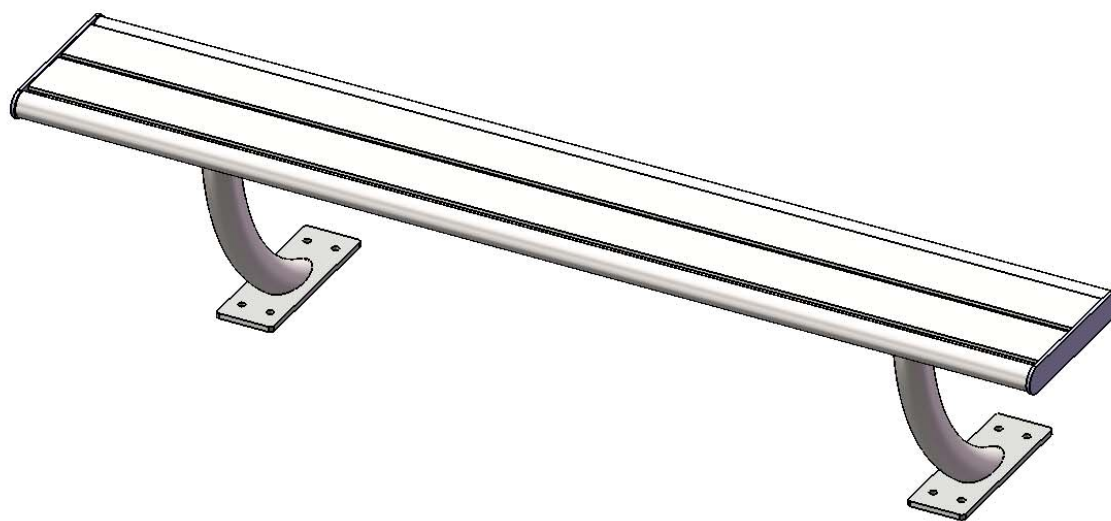

Model #
B6ACSM

 **SUPERIOR**[®]
RECREATIONAL PRODUCTS
A **PLAYCORE** Company

HARDWARE

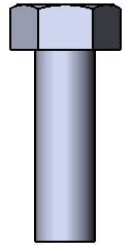

5/16" x 1"
Machine Bolt

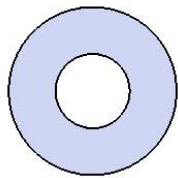

5/16" Washer

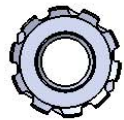

5/16" Kep Nut

TOOLS REQUIRED

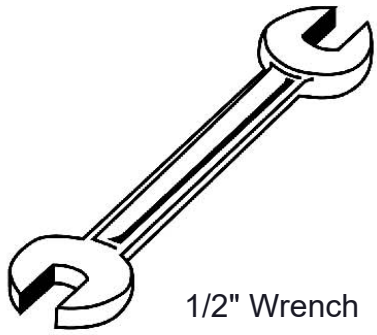

1/2" Wrench

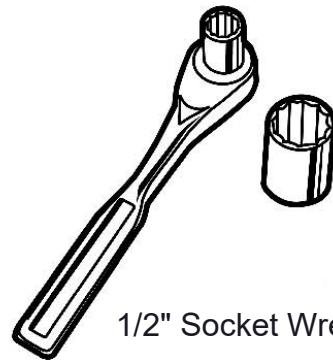

1/2" Socket Wrench

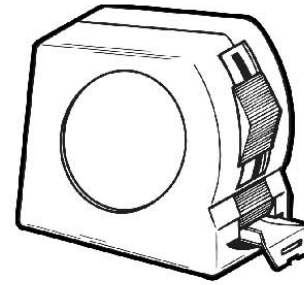

Tape Measure

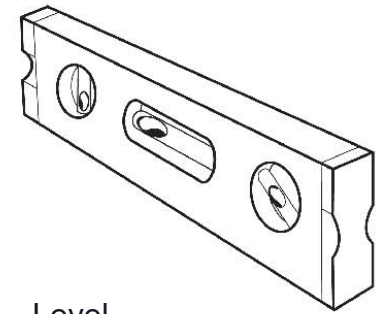

Level

PRODUCT SPECIFICATIONS

B6ACSM ACADIA SURFACE MOUNT BENCH WITHOUT BACK

Seat: Seat shall be made from 1-5/8" OD x 13ga steel tube and 1/4" x 4" flat steel plate. The ends shall be 1/4" thick steel plate. Electrically MIG welded.

Coating: Steel is sandblasted to near white condition. Coated with zinc rich epoxy primer and top coated with electrostatic powder coat, oven cured.

Frame: 2-3/8" O.D. x 12 gauge pre-galvanized structural steel tubing. Seat/back support is bent over a mandrel through the bend radius producing a wrinkle free bend. Tube ends are pre-galvanized steel capped. Seat mounting points are 7 gauge x 1-1/2" die stamped steel flat bar. A 4" x 12" steel plate makes up the surface mount footing. The surface mount plate has four holes for stable mounting. All electrically MIG welded.

Frame Coating: Steel is sandblasted to near white condition. Coated with zinc rich epoxy primer and top coated with electrostatic powder coat, oven cured.

Hardware: All stainless steel hardware fasteners.

Dimensions: 6' surface mount bench without back. Seat is 12-3/16" wide x 72" long. Seat height is 18-1/4". Total depth of bench with back is 21-3/16".

COMPONENTS

Attach the 6' Seat to the legs using specified hardware.

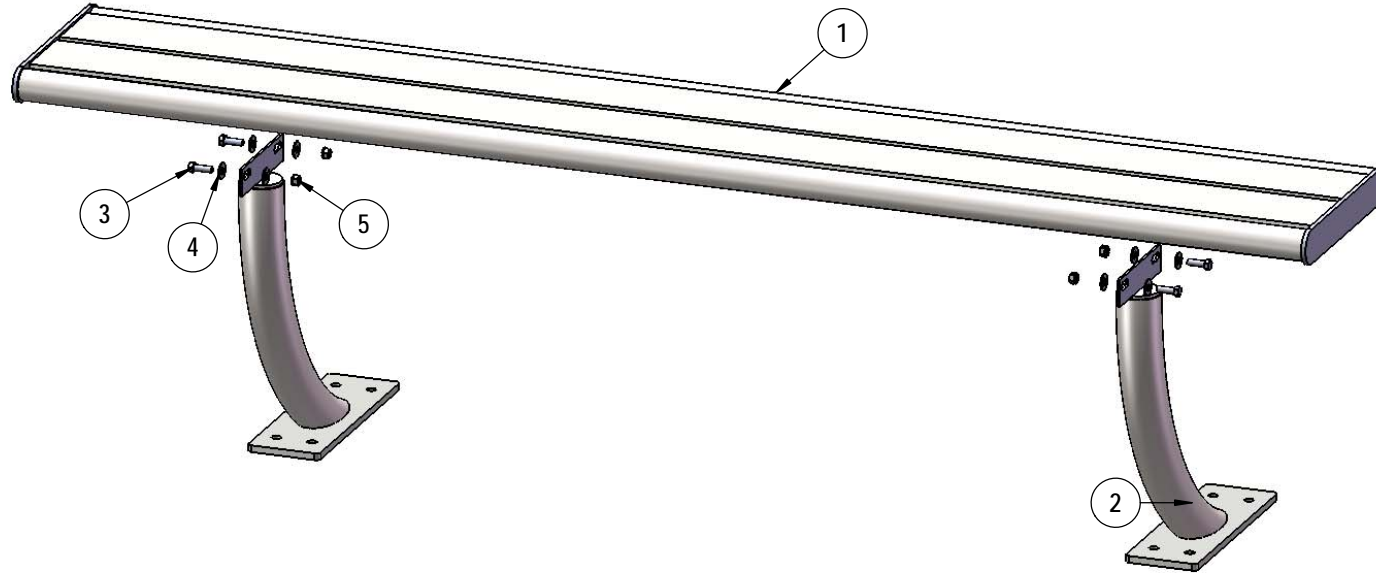

Recommended Surface Mount Hardware:
 3/8" x 3-1/2" Concrete Expansion Anchor Bolts
 (Not Included)

ITEM NO.	PartNo	DESCRIPTION	QTY
1	01-01-0692	Hartford 6' Seat/Back Plank	1
2	01-01-0684	Hartford Series Without back Leg - welded	2
3	33-05-0029	5/16" x 1" Machine Bolt (SS)	4
4	33-02-0007	5/16" SS Washer	8
5	33-03-0012	5/16" Kep Nut (SS)	4

OVERALL DIMENSIONS

