

Site Amenities

BY SUPERIOR RECREATIONAL PRODUCTS

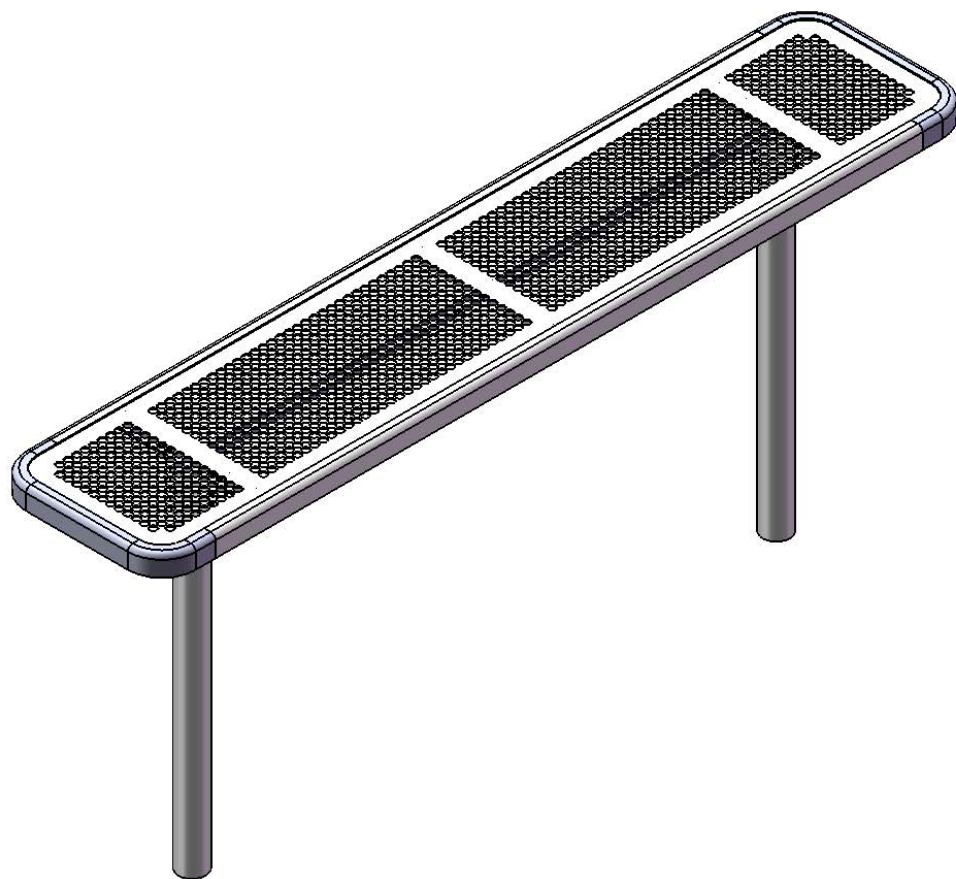

Model # B6PLAYERINNVS

HARDWARE

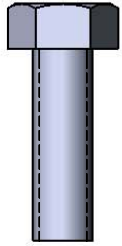

5/16" x 1"
Machine Bolt

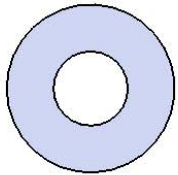

5/16" Washer

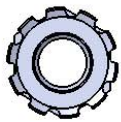

5/16" Kep Nut

PRODUCT SPECIFICATIONS

B6PLAYERINNVS DELUXE INGROUND BENCH WITHOUT BACK

Seat: 11 gauge die formed angle frame 1"x1-7/8" with 3" radius corners. 12 gauge sheet steel is precision punched with a 5/8" hole. 7 gauge x 1-1/2" flat bar center support and mounting bracket understructure. Electrically MIG welded.

Coating: Oven fused functionalized polyethylene copolymer-based thermoplastic. Fluidized bed coating application with superior mechanical performance, impact resistance and UV-stability.

Frame: 2-3/8" O.D. x 12 gauge pre-galvanized structural steel tubing. Tube ends are pre-galvanized steel capped. Seat mounting points are 7 gauge x 1-1/2" die stamped steel flat bar. All electrically MIG welded.

Frame Coating: Electrostatic powder coated application oven cured.

Hardware: All stainless steel hardware fasteners.

Dimensions: 6' bench inground without back. Seats are 15" wide x 72" long. Seat height is 18". Total depth of bench is 15".

COMPONENTS

Attach the 6' Punched Deluxe Seat to the Legs using specified hardware.

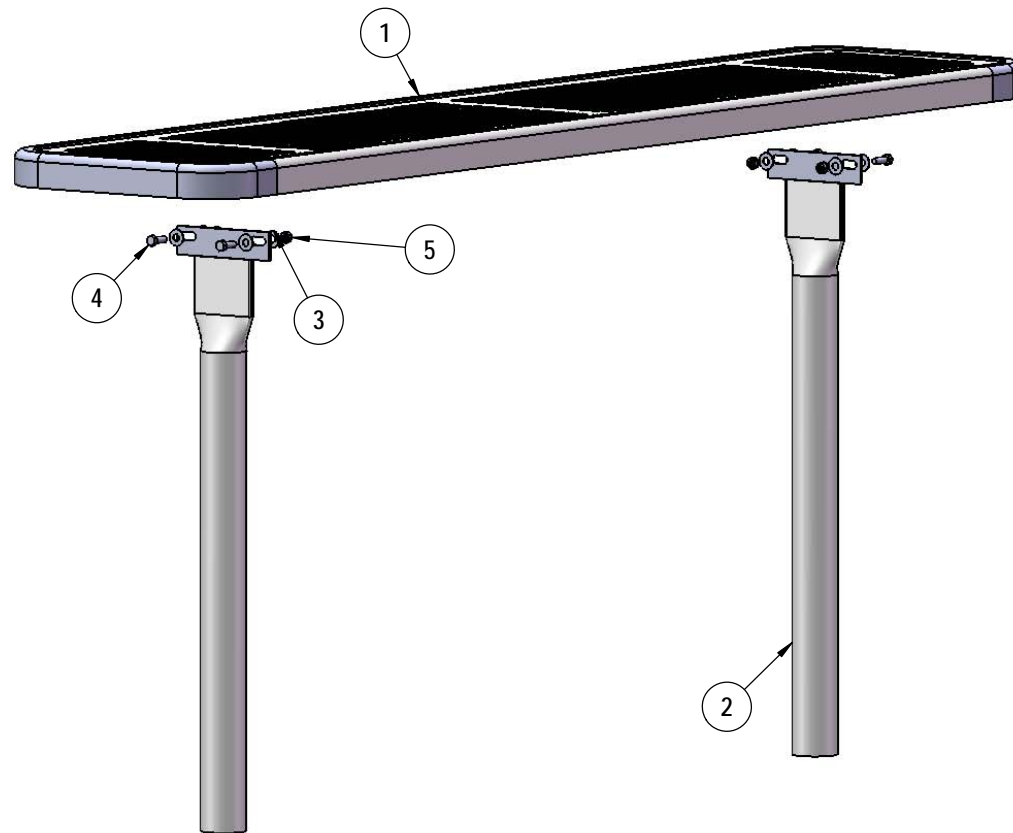

ITEM NO.	PartNo	DESCRIPTION	QTY
1	T-DP72-S	6' Punched Deluxe Seat	1
2	P-V942S	942S VINYL LEG	2
3	33-02-0007	5/16" SS Washer	8
4	33-05-0029	5/16" x 1" Machine Bolt (SS)	4
5	33-03-0012	5/16" Kep Nut (SS)	4

FOOTINGS

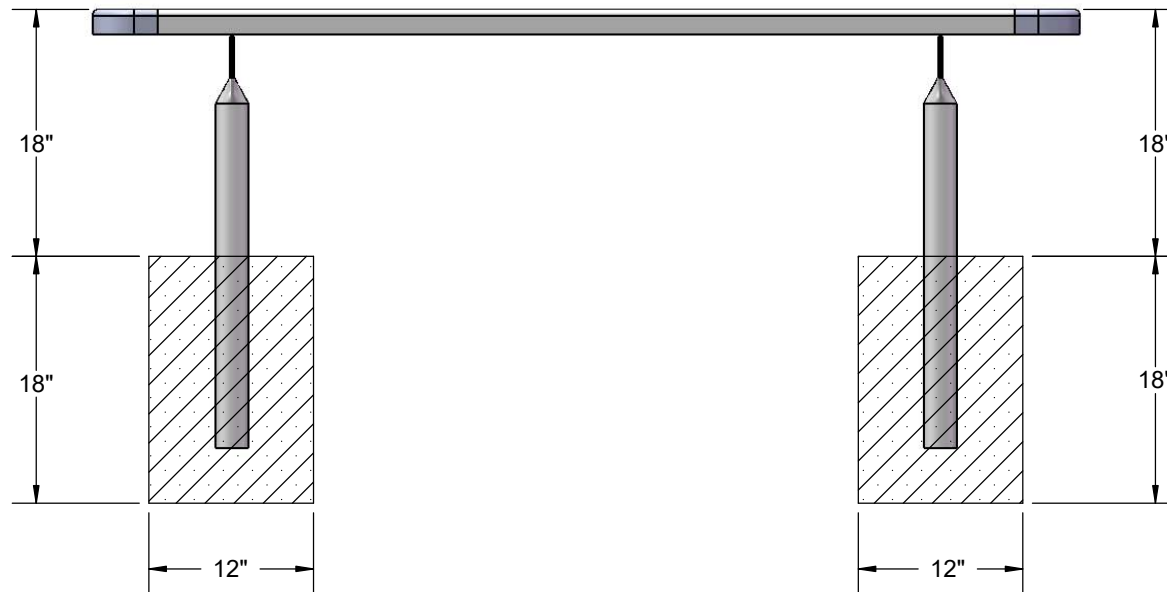
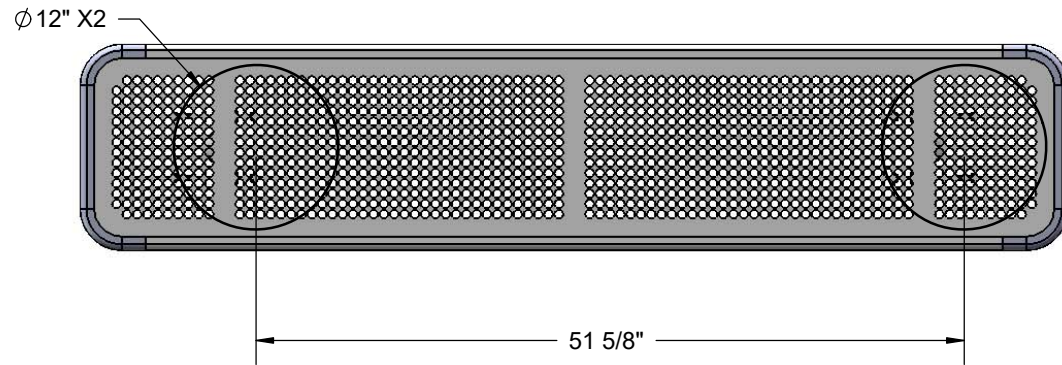

Estimated Required Concrete:
7 - 50 lb. Bags of Concrete Mix

OVERALL DIMENSIONS

