

Site Amenities

BY SUPERIOR RECREATIONAL PRODUCTS

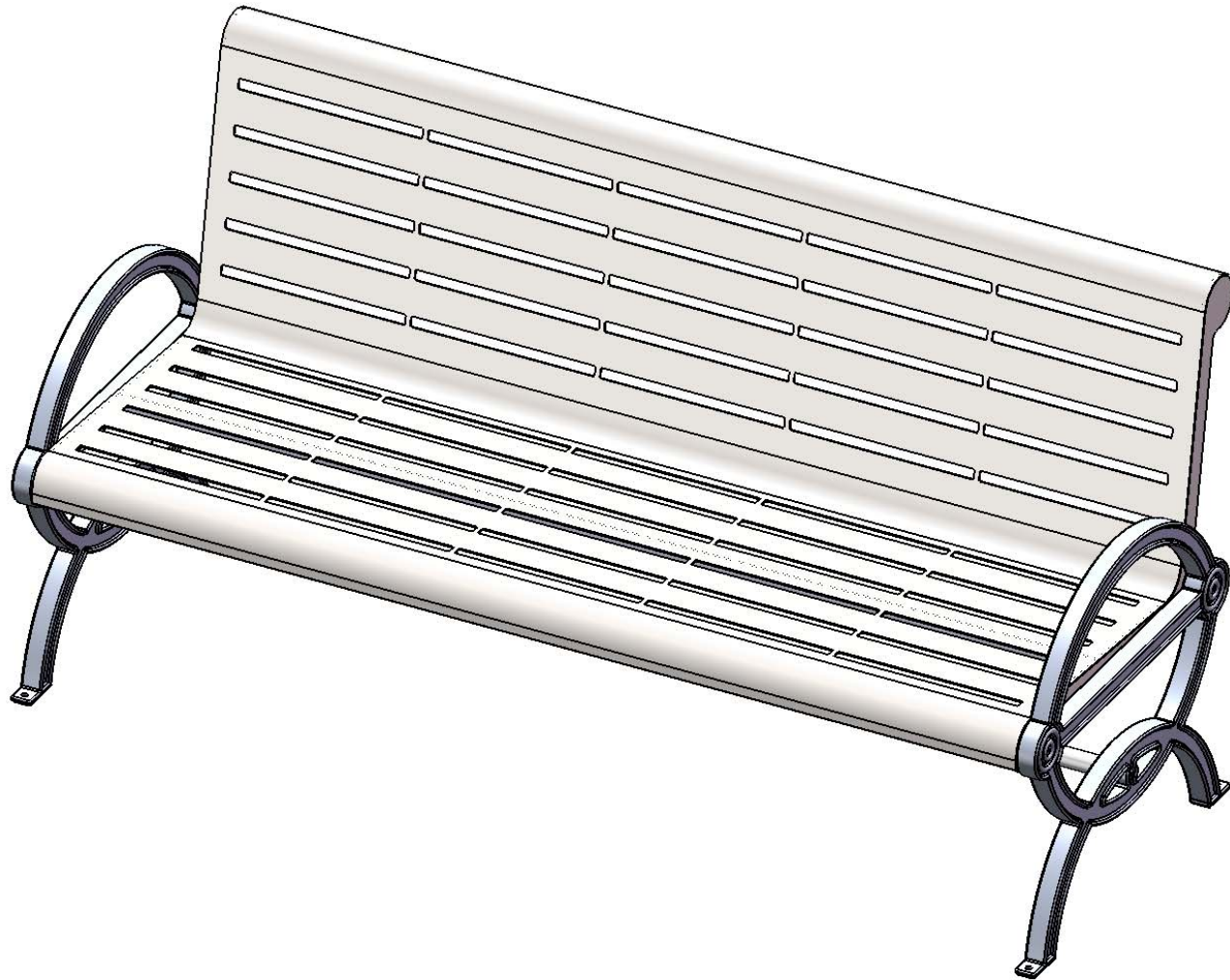

Model #
B6WBGW-ST-H

 **SUPERIOR**[®]
RECREATIONAL PRODUCTS
A **PLAYCORE** Company

HARDWARE

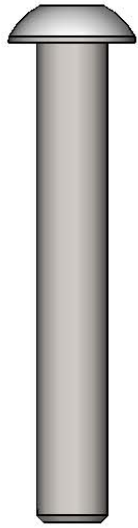

3/8" X 2-1/2"
Button Head Bolt

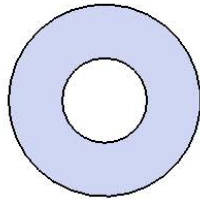

3/8" Washer

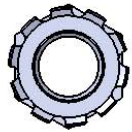

3/8" Kep Nut

TOOLS REQUIRED

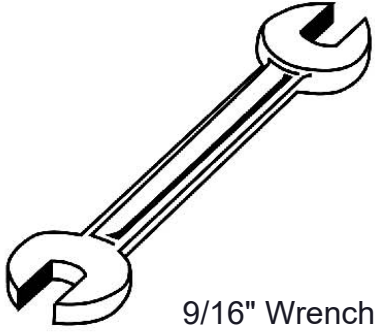

9/16" Wrench



9/16" Socket Wrench

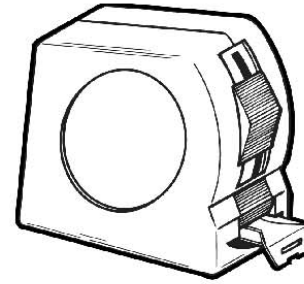

Tape Measure

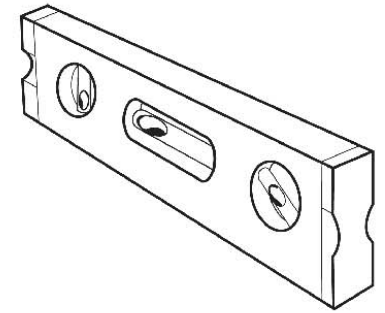

Level

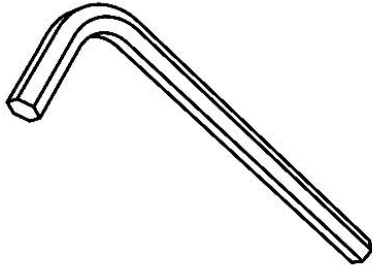

7/32 Allen Wrench

PRODUCT SPECIFICATIONS

B6WBGW-ST-H GATEWAY SLAT BENCH WITH BACK

Seats: Seats dimensions are 30" x 48". 12 gauge sheet steel is precision punched to create the slat pattern. End plates are made of 7 gauge flat steel plate. Reinforced with 3/16 x 1-1/2" flat strip. Electrically MIG welded.

Frame: Legs are cast aluminum.

Frame Coating: Metal is sandblasted to near white condition. Coated with zinc rich epoxy primer and top coated with electrostatic powdercoat, oven cured.

Hardware: All fasteners are stainless steel.

Dimensions: 6' portable/surface mount bench with back. Seats are 30" wide x 72" long. Seat height is 18-1/2" from the ground to the top of the seat. The overall dimensions are 30-1/4" x 75" x 37-1/2" tall.

COMPONENTS

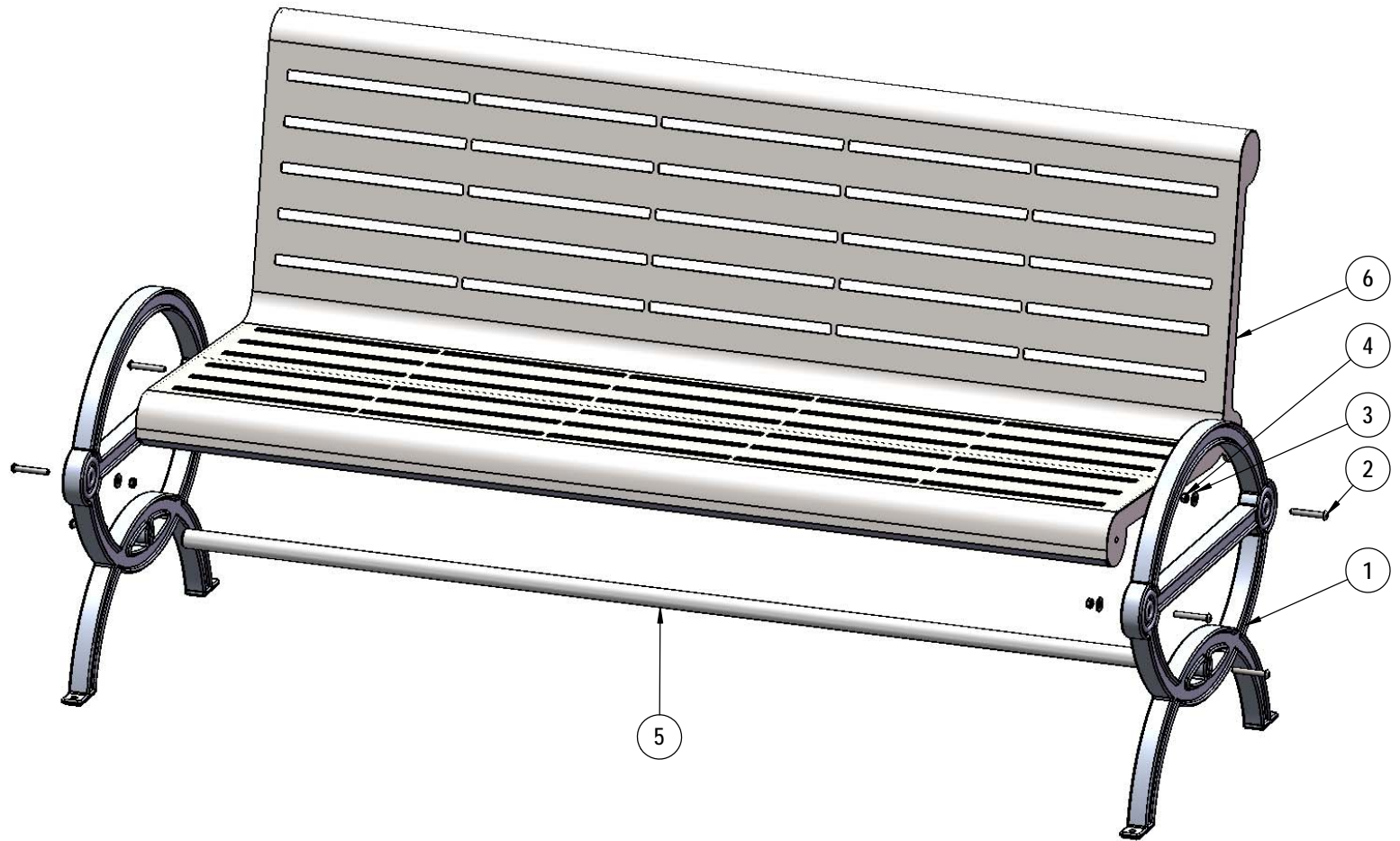

Optional Surface Mount Hardware:
 3/8" x 3-1/2" Concrete Expansion Anchor Bolts
 (Not Included)

ITEM NO.	PartNo	DESCRIPTION	QTY
1	11-01-CAST8	Durham Casted Aluminum Bench Frame	2
2	33-06-0093	3/8"-16 x 2-1/2" Button Head Bolt (SS)	6
3	33-02-0008	3/8" Flat Washer (SS)	4
4	33-03-0013	3/8" Kep Nut (SS)	4
5	01-01-0498	72" Support Bar	1
6	01-01-0600	6' H Slat Durham w/back - Welded	1

STEP 1

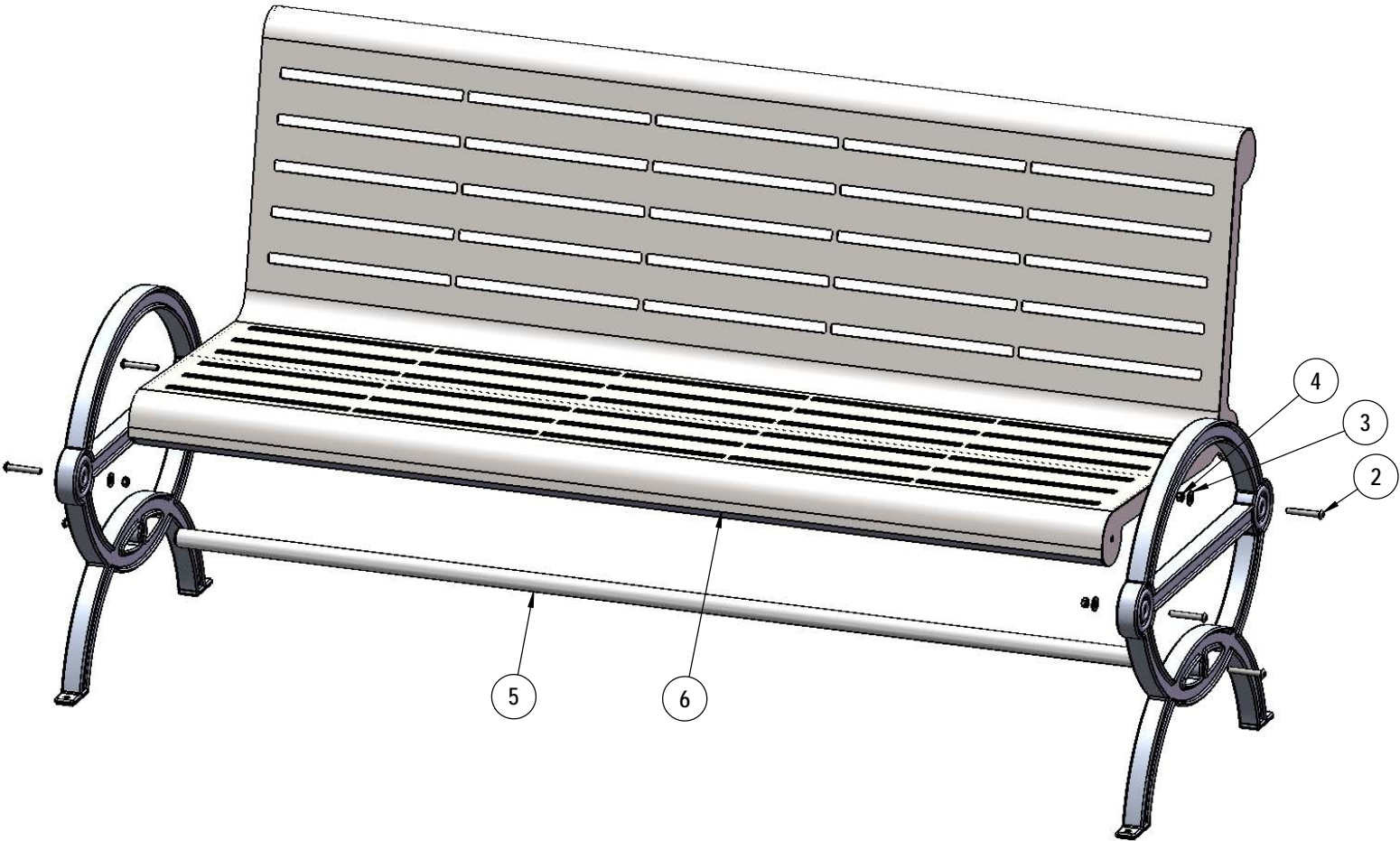

Attach the Seat and Support Bar to the Cast End Frames using the specified hardware.

OVERALL DIMENSIONS

