

Site Amenities

BY SUPERIOR RECREATIONAL PRODUCTS



Model #
B6WBULPERFS

 **SUPERIOR**[®]
RECREATIONAL PRODUCTS
A **PLAYCORE** Company

HARDWARE

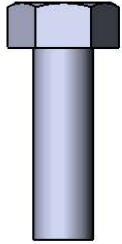

5/16" x 1"
Machine Bolt

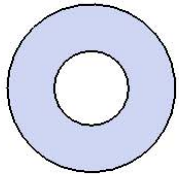

5/16" Washer

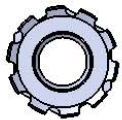

5/16" Kep Nut

PRODUCT SPECIFICATIONS

B6WBULPERFS INGROUND BENCH WITH BACK

Seats & Back: 11 gauge die formed angle frame 1"x1-7/8" with 3" radius corners. Seat and back plates are fabricated from a 14ga plate. Holes are precision punched at 3/4" diameter. 10 gauge x 1-1/2" flat bar center support and mounting bracket understructure. Electrically MIG welded.

Coating: Oven fused functionalized polyethylene copolymer-based thermoplastic. Fluidized bed coating application with superior mechanical performance, impact resistance and UV-stability.

Frame: 2-3/8" O.D. x 12 gauge pre-galvanized structural steel tubing. Seat/back support is bent over a mandrel through the bend radius producing a wrinkle free bend. Tube ends are pre-galvanized steel capped. Seat mounting points are 7 gauge x 1-1/2" die stamped steel flat bar. All electrically MIG welded.

Frame Coating: Electrostatic powder coated application oven cured.

Hardware: All stainless steel hardware fasteners.

Dimensions: 6' bench inground with back. Seats and back 10" wide x 72" long. Seat height is 18", seat back height is 34". Total depth of seat with back is 21-1/4".

COMPONENTS

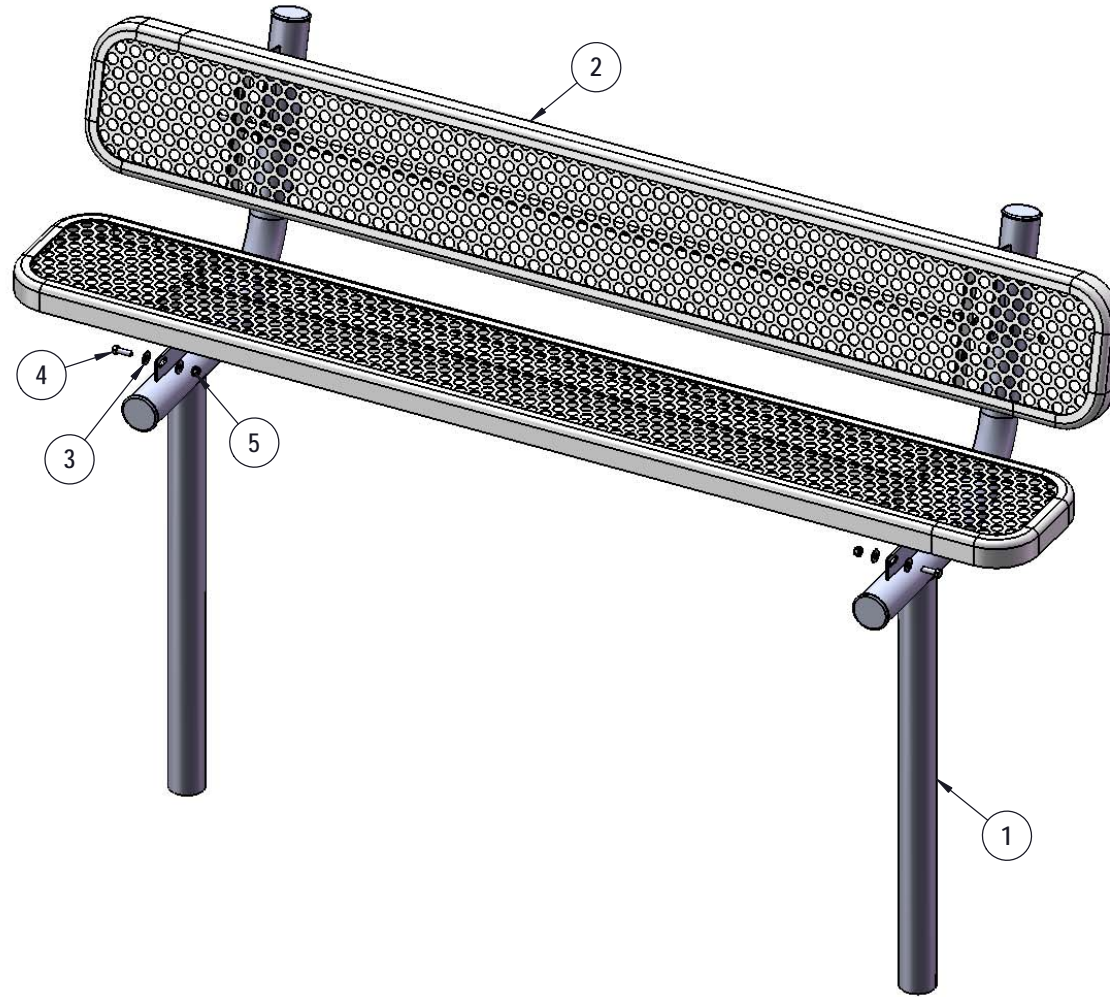

ITEM NO.	PartNo	DESCRIPTION	QTY
1	P-V940S	940 In Ground Leg	2
2	T-EP72-S	6' x 10" perf seat	2
3	33-02-0007	5/16" SS Washer	16
4	33-05-0029	5/16" x 1" Machine Bolt (SS)	8
5	33-03-0012	5/16" Kep Nut (SS)	8

STEP 1



Attach the seat plank to the legs using specified hardware.

STEP 2



Repeat Step 1 for the back.

FOOTINGS

Estimated Required Concrete: 7 - 50 lb. Bags of Concrete

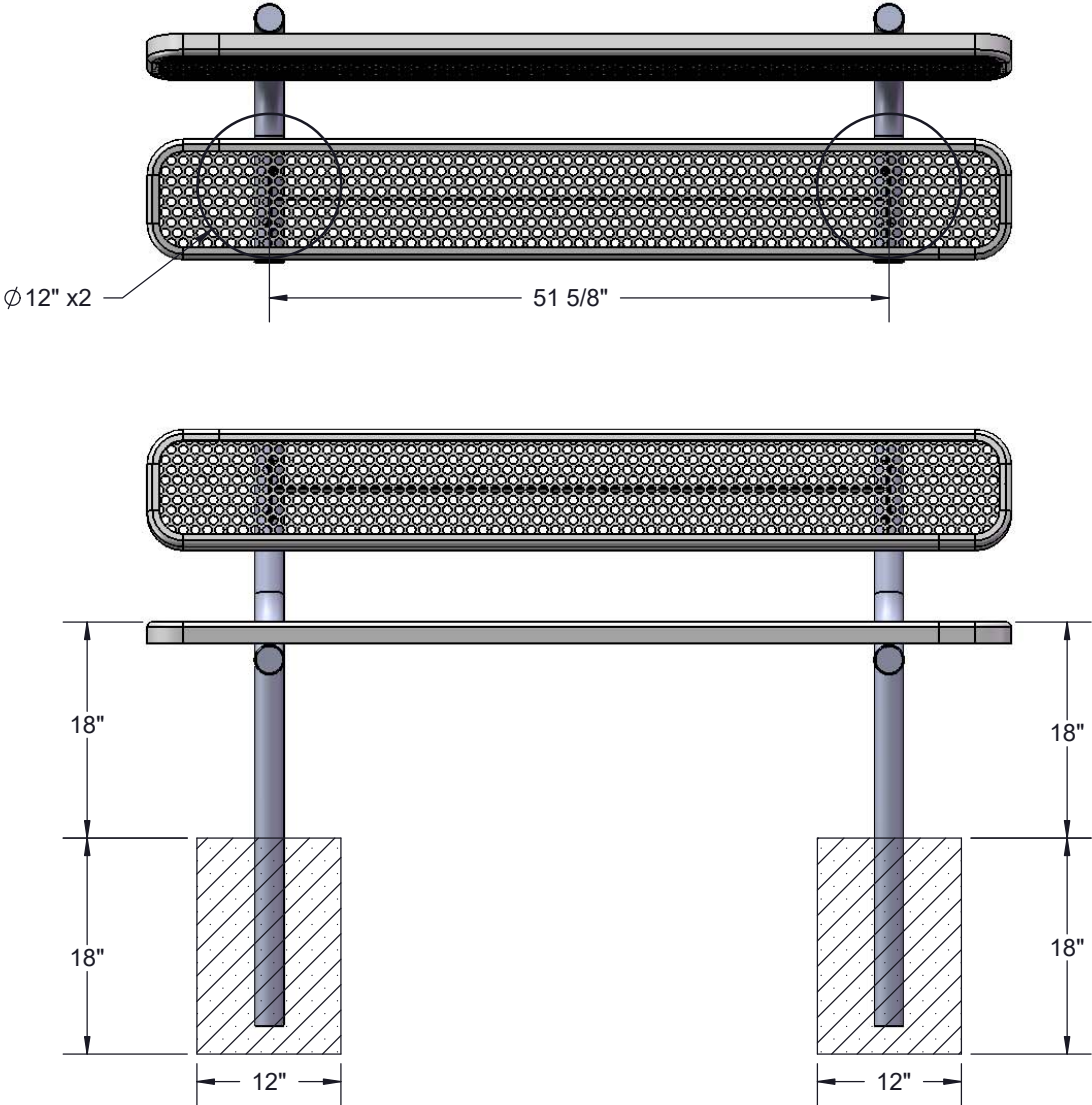

OVERALL DIMENSIONS

