

Site Amenities

BY SUPERIOR RECREATIONAL PRODUCTS



Model # B8ULPERFP

 **SUPERIOR**[®]
RECREATIONAL PRODUCTS
A **PLAYCORE** Company

HARDWARE

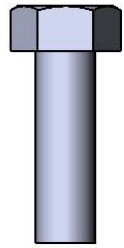

5/16" x 1"
Machine Bolt

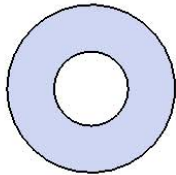

5/16" Washer



5/16" Kep Nut

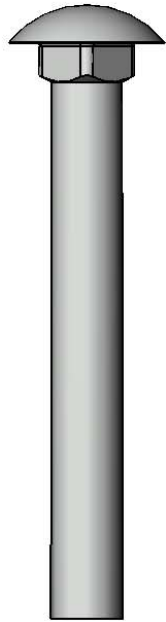

3/8" x 3"
Carriage Bolt

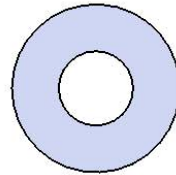

3/8" Washer

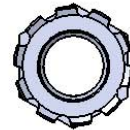

3/8" Kep Nut

PRODUCT SPECIFICATIONS

B8ULPERFP PORTABLE BENCH WITHOUT BACK

Seat: 11 gauge die formed angle frame 1"x1-7/8" with 3" radius corners. 12 gauge sheet steel is precision punched with a 3/4" hole. 10 gauge x 1-1/2" flat bar center support and mounting bracket understructure. Electrically MIG welded.

Coating: Oven fused functionalized polyethylene copolymer-based thermoplastic. Fluidized bed coating application with superior mechanical performance, impact resistance and UV-stability.

Frame: 2-3/8" O.D. x 12 gauge pre-galvanized structural steel tubing. Tube ends are pre-galvanized steel capped. Seat mounting points are 7 gauge x 1-1/2" die stamped steel flat bar. Cross braces are 1" O.D. x 16 gauge pre-galvanized structural steel tubing. All electrically MIG welded.

Frame Coating: Electrostatic powder coated application oven cured.

Hardware: All stainless steel hardware fasteners.

Dimensions: 8' bench portable without back. Seats are 10" wide x 96" long. Seat height is 18-1/4". Total depth of bench is 22".

COMPONENTS

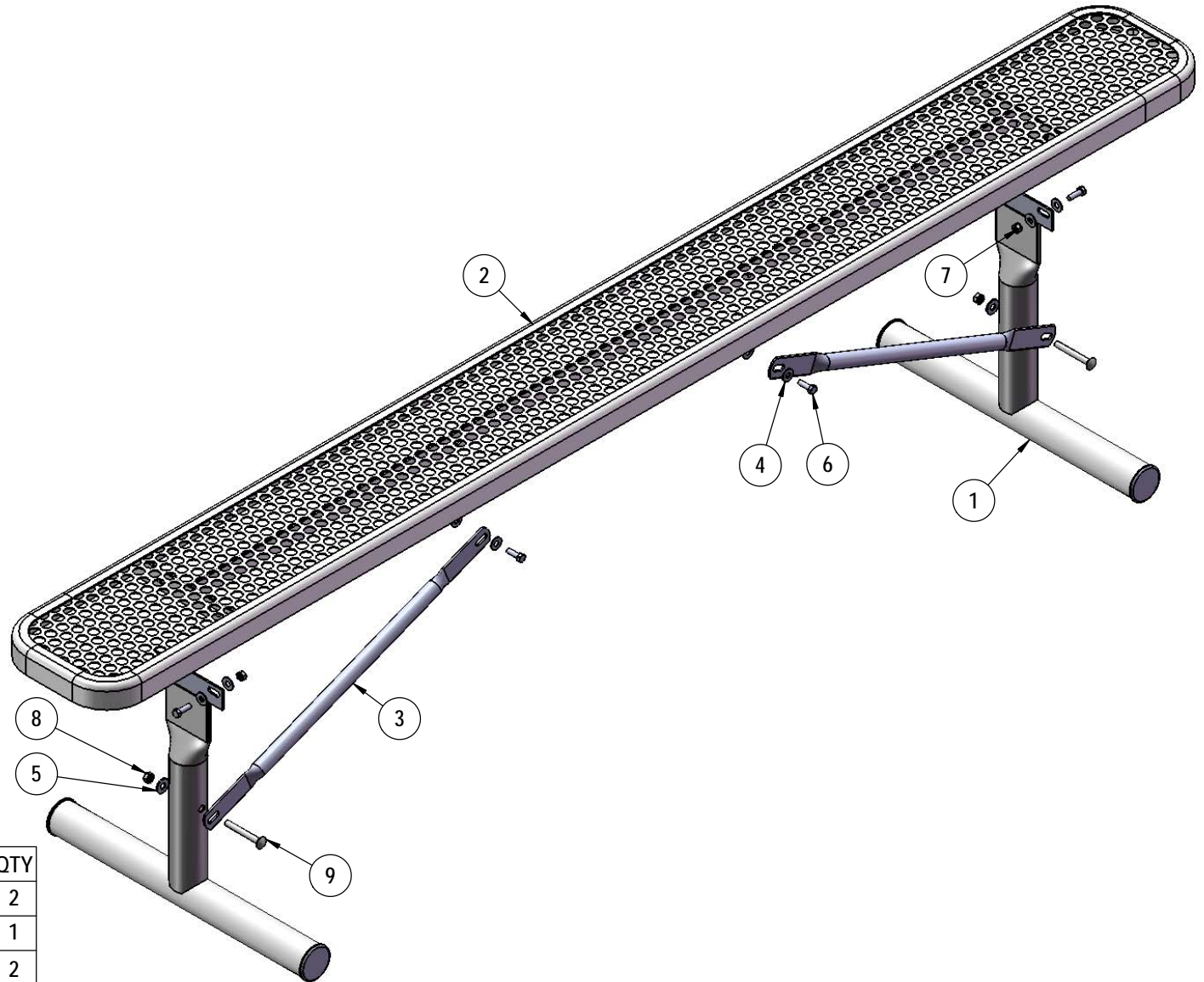

ITEM NO.	PartNo	DESCRIPTION	QTY
1	P-V942P	942P Vinyl Leg	2
2	T-EP96-S	8' x 10" perf seat	1
3	04-04-0019	26 1/2" Brace	2
4	33-02-0007	5/16" SS Washer	12
5	33-02-0008	3/8" Flat Washer (SS)	2
6	33-05-0029	5/16" x 1" Machine Bolt (SS)	6
7	33-03-0012	5/16" Keps Nut (SS)	6
8	33-03-0013	3/8" Keps Nut (SS)	2
9	33-06-0058	3/8" x 3" Carriage Bolt (SS)	2

STEP 1

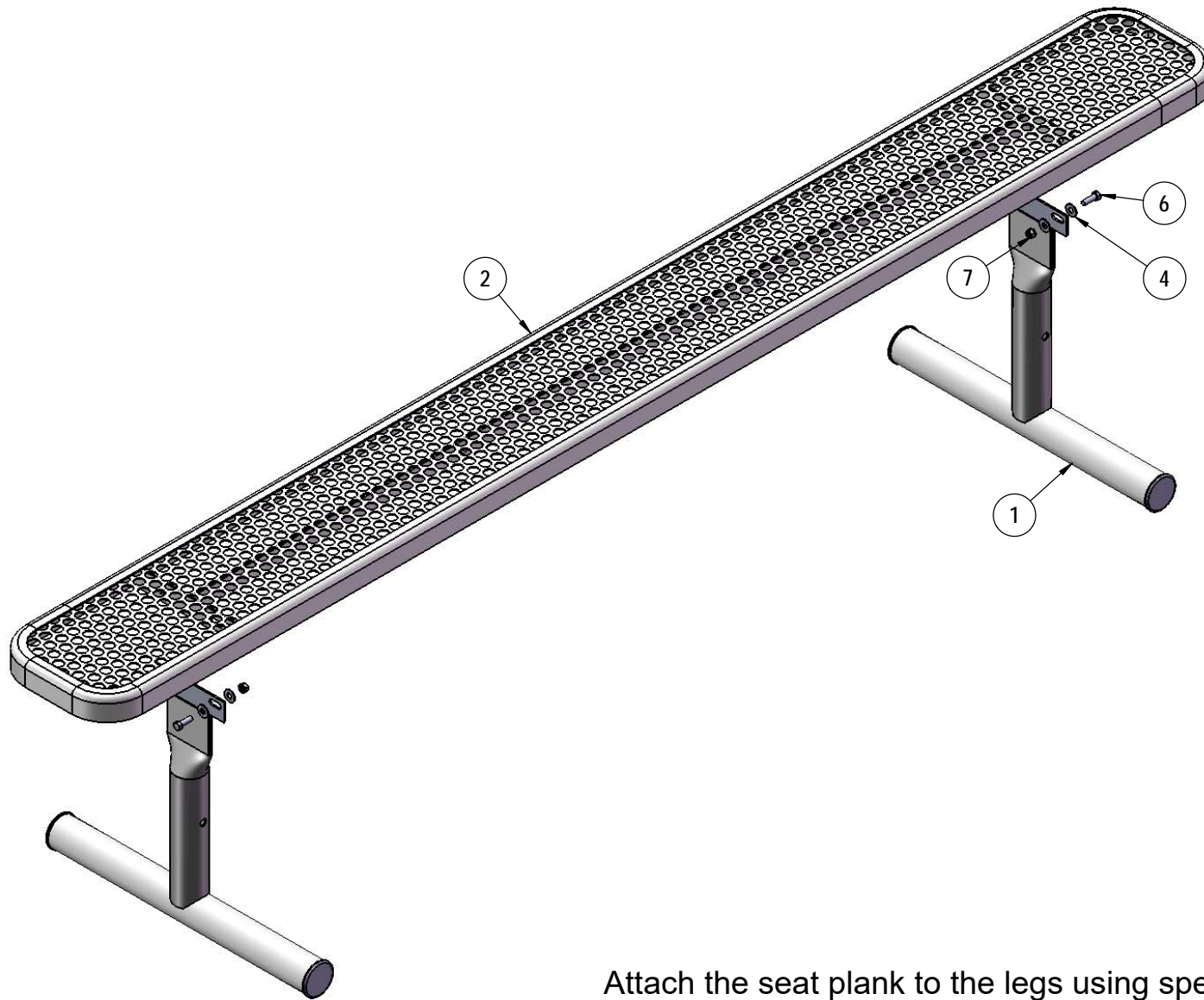

Attach the seat plank to the legs using specified hardware.

STEP 2

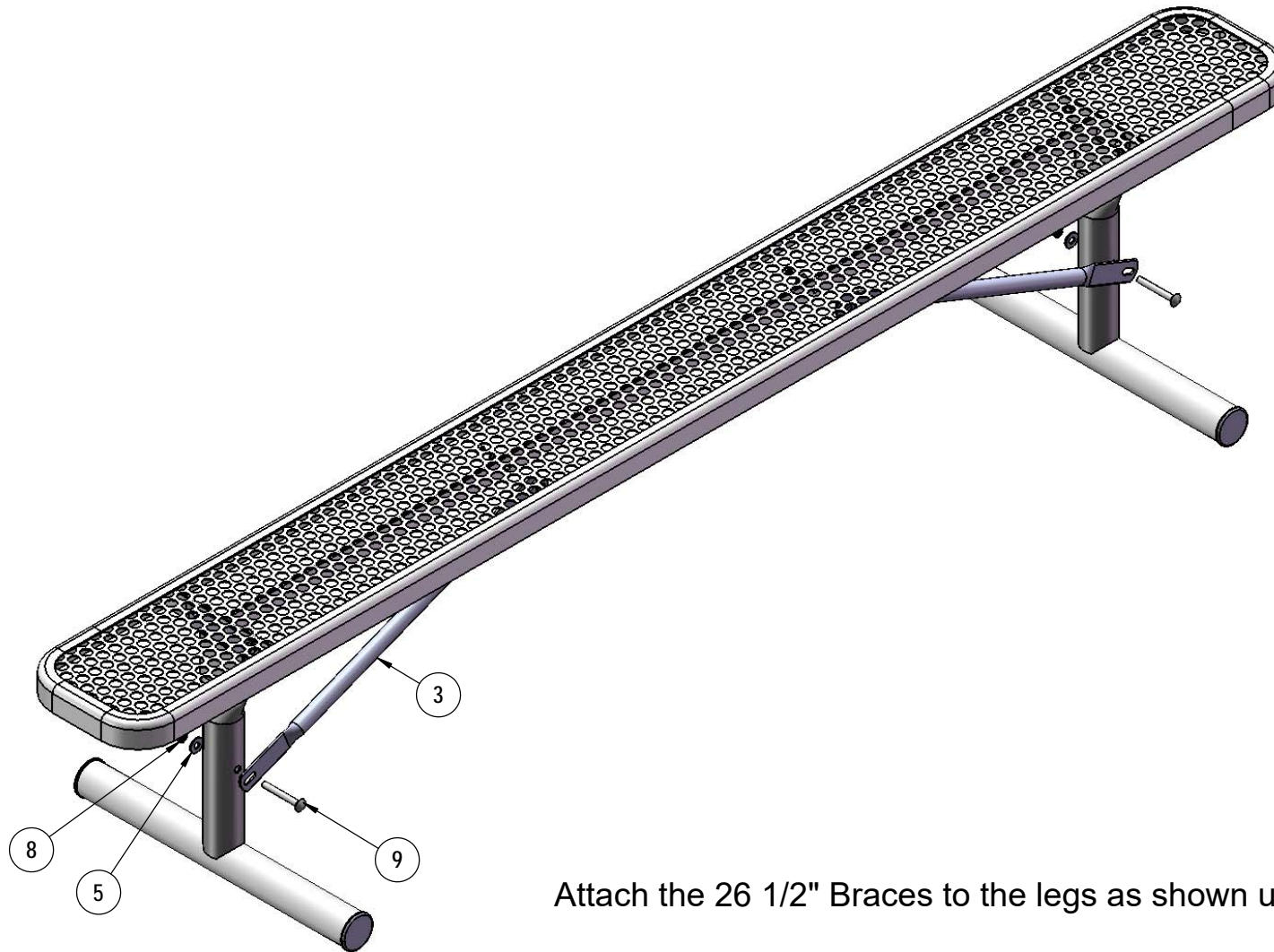

Attach the 26 1/2" Braces to the legs as shown using specified hardware.

OVERALL DIMENSIONS

