

Model # B8WBBCGS

HARDWARE

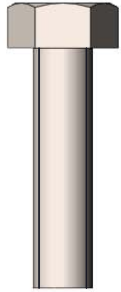

5/16" x 1-1/4"
Machine Bolt

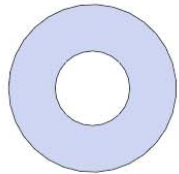

5/16" Washer



5/16" Kep Nut

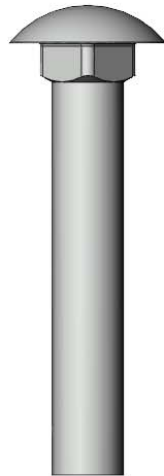

3/8" x 2-1/4"
Carriage Bolt

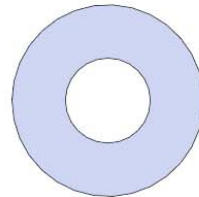

3/8" Washer



3/8" Kep Nut

TOOLS REQUIRED

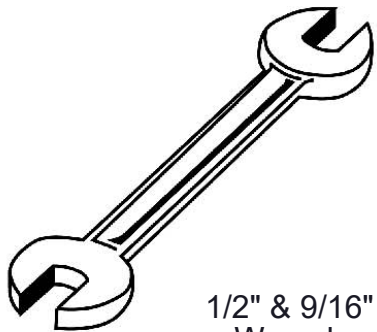

1/2" & 9/16"
Wrench

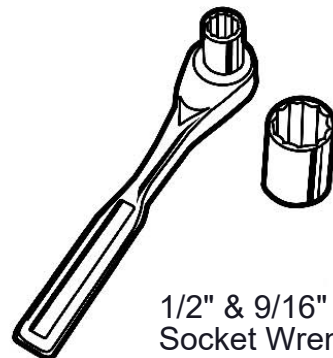

1/2" & 9/16"
Socket Wrench

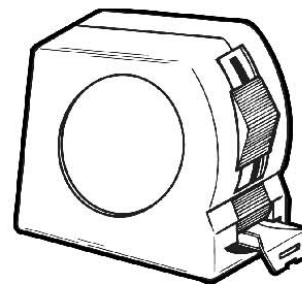

Tape Measure

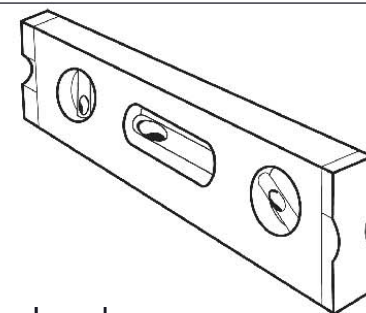

Level

PRODUCT SPECIFICATIONS

B8WBBCGS **8' Biscayne Geometric Bench with Back, Inground Mount**

Seat and Back: Seats are fabricated from 1" x 1" x 11 ga. steel square and 2" x 1" x 11ga steel tubing. Attachment brackets are 7ga formed sheet steel. Seat back shall be 1-1/2" x 1/4" flat steel strips. Front and top rails shall be 1" x 2" x 11 ga. steel rectangular tubing. Side rails shall be 2" x 2" x 11ga square tubing. All electrically MIG welded.

Frame: Bench legs shall be fabricated from 4" x 4" x 11 gauge pre-galvanized steel square tubing. Attachment plates are made from 10ga sheet steel. Surface mounting plates shall be 8" sq x 1/4" steel plate. All electrically MIG welded.

Coating: Steel is sandblasted to near white condition. Coated with zinc rich epoxy primer and top coated with electrostatic powder coat, oven cured.

Hardware: All stainless steel hardware.

Dimensions: 8' inground bench with back. Seats are 15-7/8" wide x 46" long. Seat height is 19" from the ground to the top of the seat. The overall dimensions are 79-3/4" x 92-7/16" x 36".

COMPONENTS

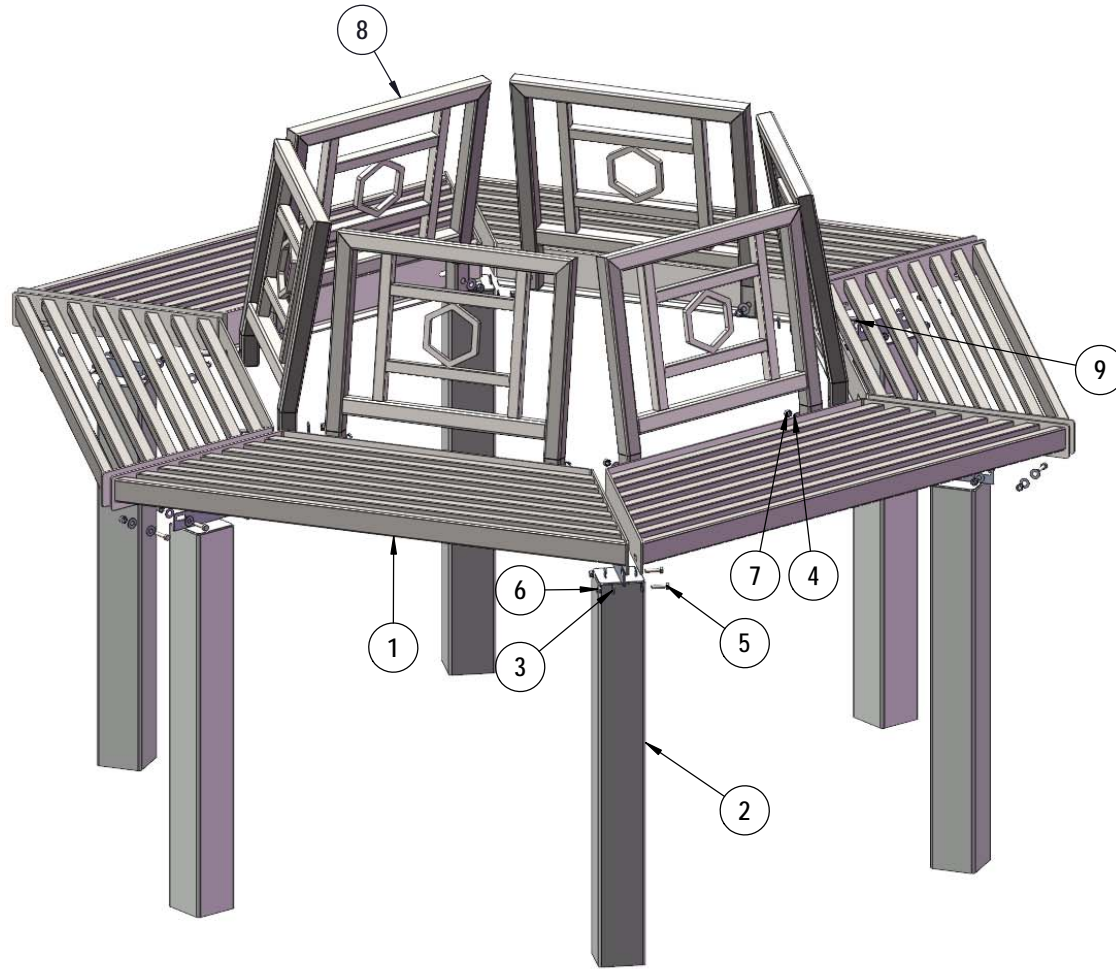

ITEM NO.	PartNo	DESCRIPTION	QTY
1	01-01-0998	Hexagon Tree Bench Seat 4'	6
2	P-V349S-S	Vinyl S Seat leg	6
3	33-02-0007	5/16" SS Washer	48
4	33-02-0008	3/8" Flat Washer (SS)	12
5	33-05-0028	5/16" x 1 1/4" Machine Bolt (SS)	24
6	33-03-0012	5/16" Kep Nut (SS)	24
7	33-03-0013	3/8" Kep Nut (SS)	12
8	01-01-1000	Hexagon Tree Bench Back 4'	6
9	33-06-0060	3/8" x 2-1/4" Carriage Bolt (SS)	12

Superior[®]
 RECREATIONAL PRODUCTS
 A PLAYCORE Company

STEP 1

Seat planks bolt together using the 2 outside attachment holes.
The legs are easier to attach if seat sections are pre-assembled in sections of 2-3.

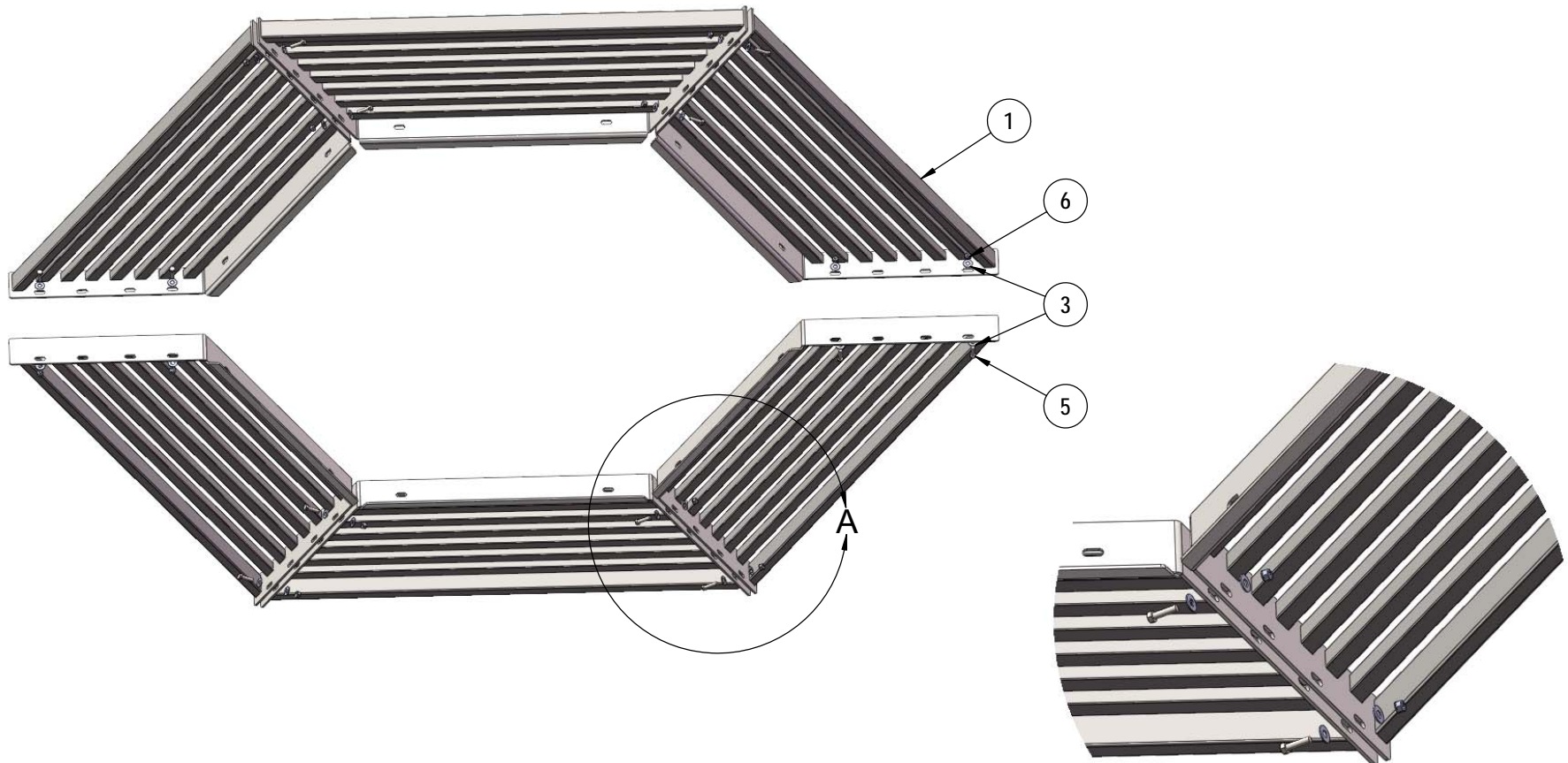

DETAIL A
SCALE 1 : 8

STEP 2

Attach legs to the planks using the 2 center attachment holes. Please note- each leg should be attached to each set of planks on the same side as you work your way around the bench.

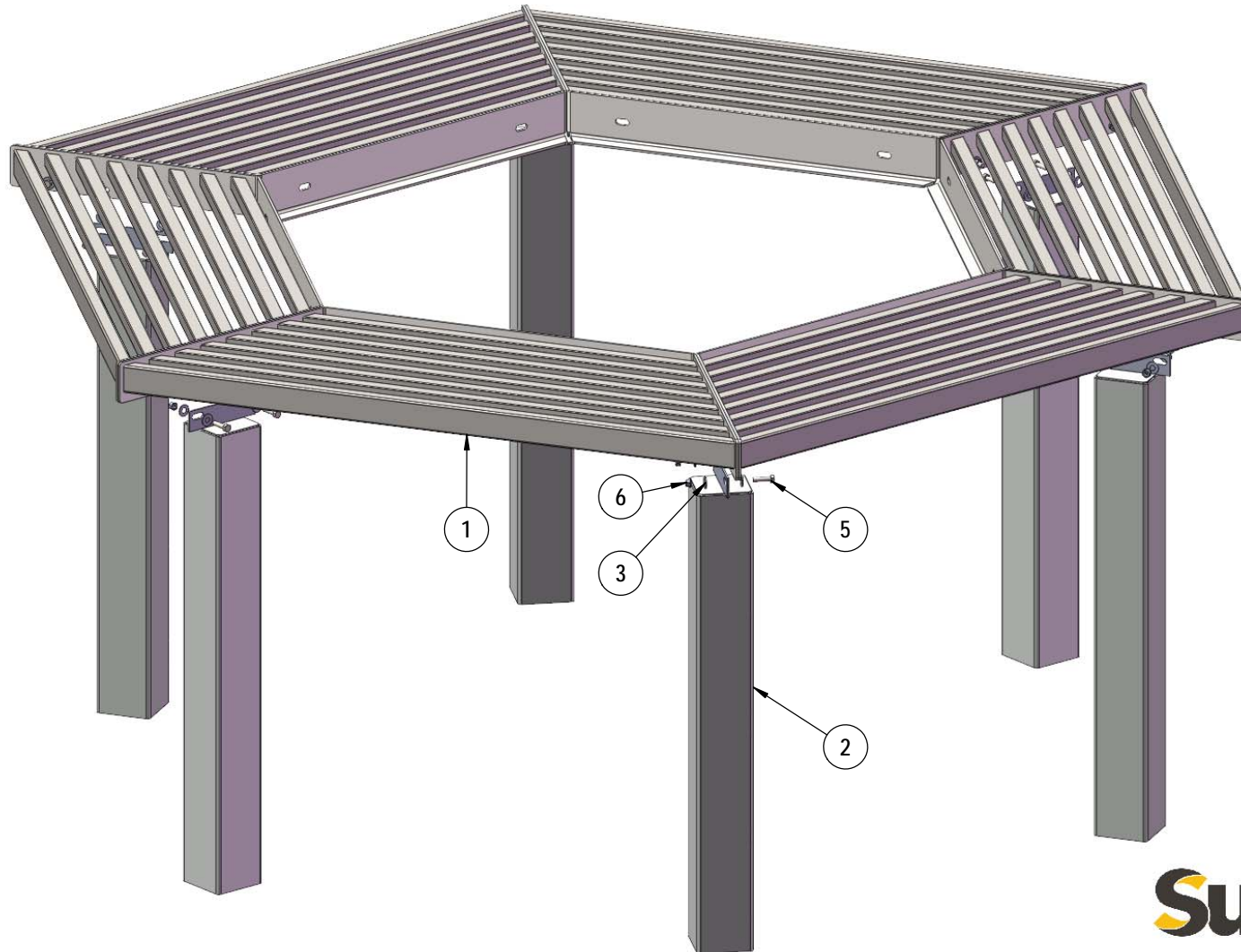

STEP 3

Attach the seat backs to the back of the seats shown using specified hardware.



FOOTINGS

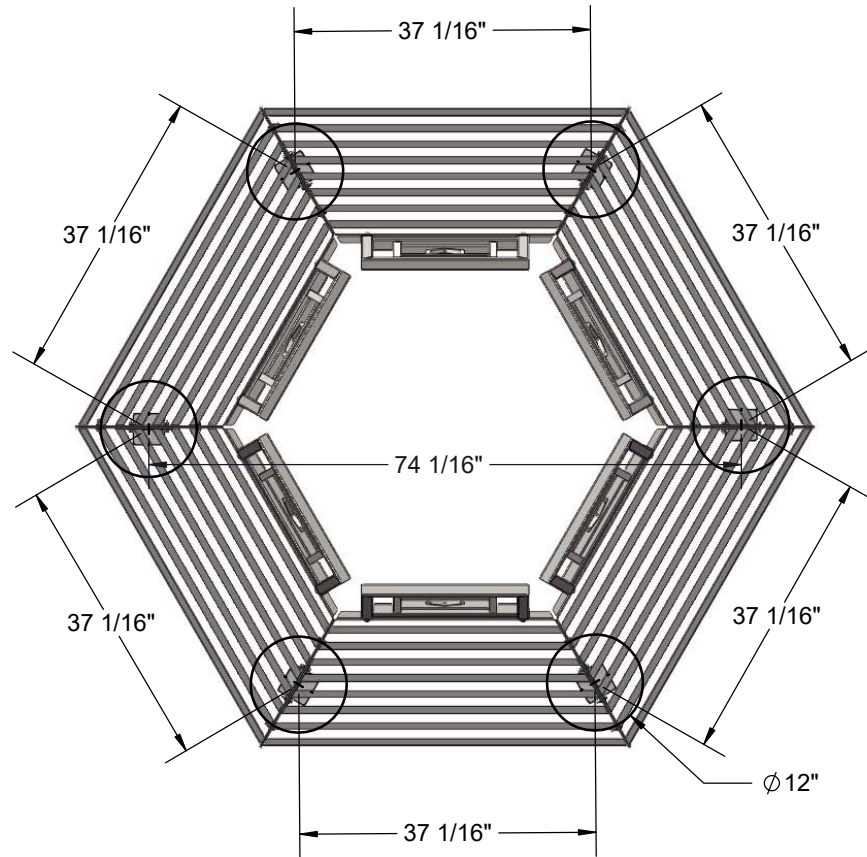

Estimated Required Concrete:
21 - 50 lb Bags of Concrete Mix

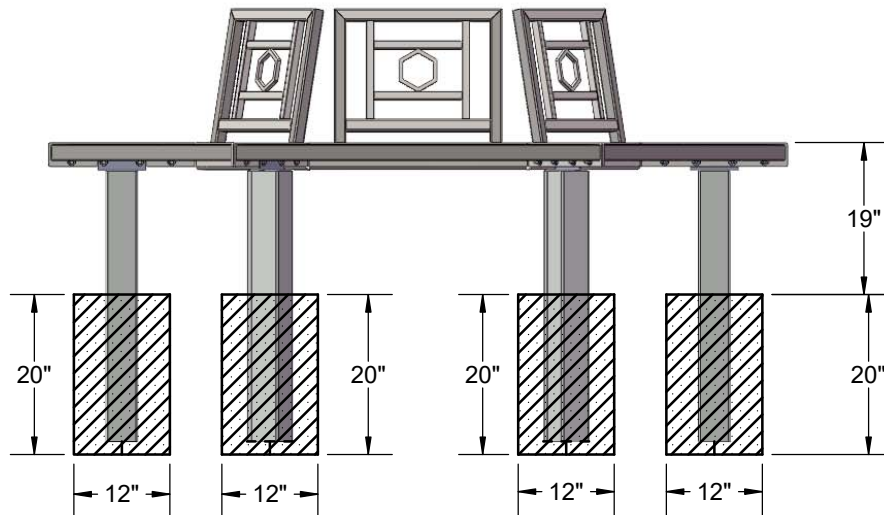

Superior[®]
RECREATIONAL PRODUCTS
A PLAYCORE Company

OVERALL DIMENSIONS

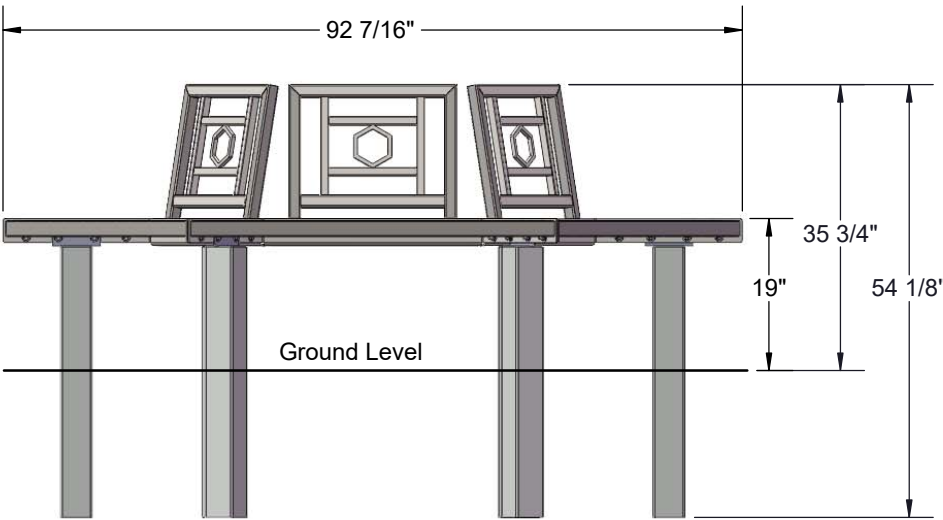
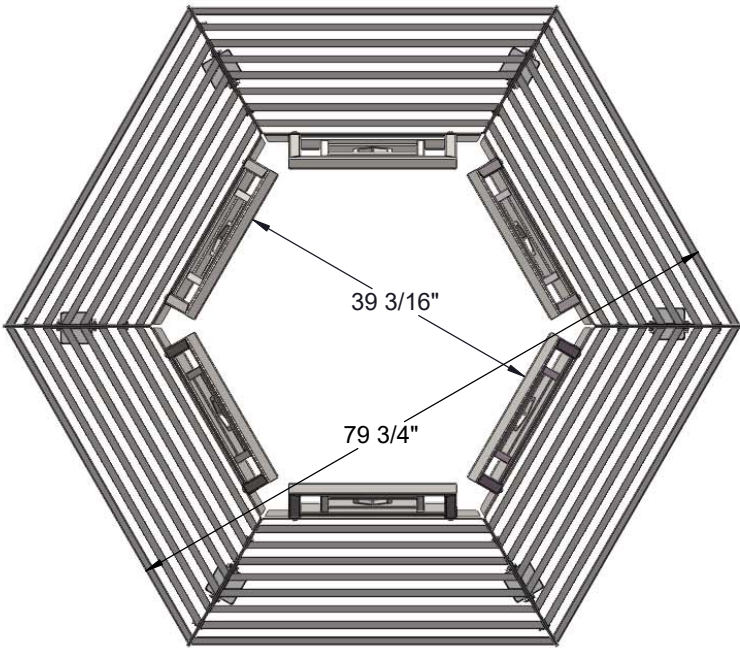

Superior[®]
RECREATIONAL PRODUCTS
A PLAYCORE Company