

Site Amenities

BY SUPERIOR RECREATIONAL PRODUCTS

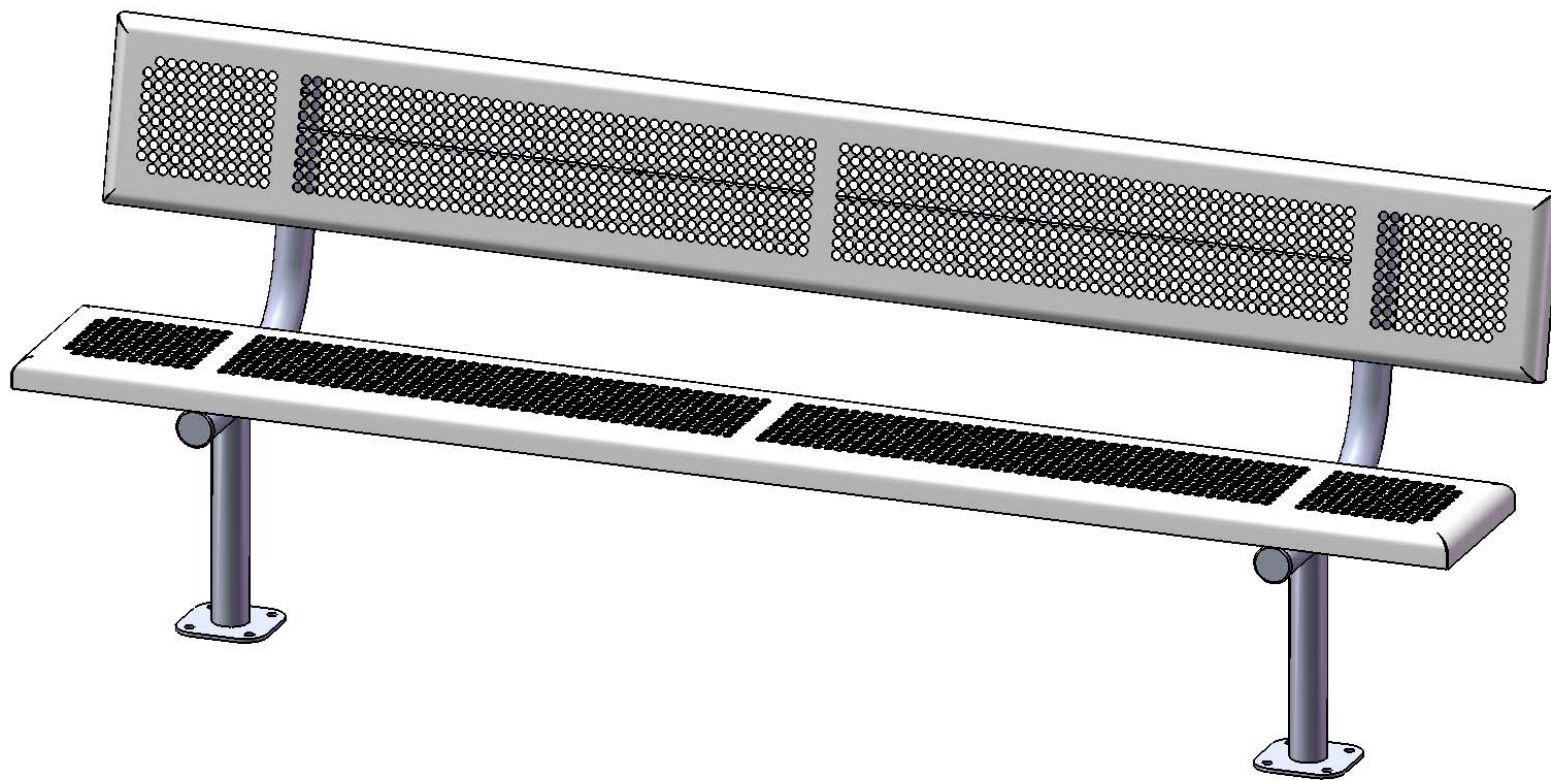

Model # B8WBPERFSM

S SUPERIOR[®]
RECREATIONAL PRODUCTS
A PLAYCORE Company

HARDWARE

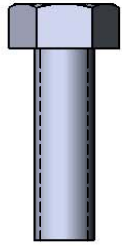

5/16" x 1"
Machine Bolt

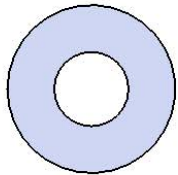

5/16" Washer

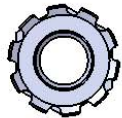

5/16" Kep Nut

PRODUCT SPECIFICATIONS

B8WBPERFSM SURFACE MOUNT BENCH WITH BACK

Seats & Back: Seats shall have a 1-1/2" radius edge, fabricated from a 14 ga. plate. Holes are precision punched with a 5/8" hole to create the punched hole pattern. The understructure/attachment plates are fabricated from 7 gauge x 1-1/2" flat bar. Electrically MIG welded.

Coating: Oven fused functionalized polyethylene copolymer-based thermoplastic. Fluidized bed coating application with superior mechanical performance, impact resistance and UV-stability.

Frame: 2-3/8" O.D. x 12 gauge pre-galvanized structural steel tubing. Seat/back support is bent over a mandrel through the bend radius producing a wrinkle free bend. Tube ends are pre-galvanized steel capped. Seat mounting points are 7 gauge x 1-1/2" die stamped steel flat bar. A 6" x 6" steel plate makes up the surface mount footing. The surface mount plate has four holes for stable mounting. All electrically MIG welded.

Frame Coating: Electrostatic powder coated application oven cured.

Hardware: All stainless steel hardware fasteners.

Dimensions: 8' bench surface mount with back. Seats and backs are 12" wide x 96" long. Seat height is 18-1/2", seat back height is 35". Total depth of seat with back is 22-1/4".

COMPONENTS

Attach the Seats to the Legs as shown using specified hardware.

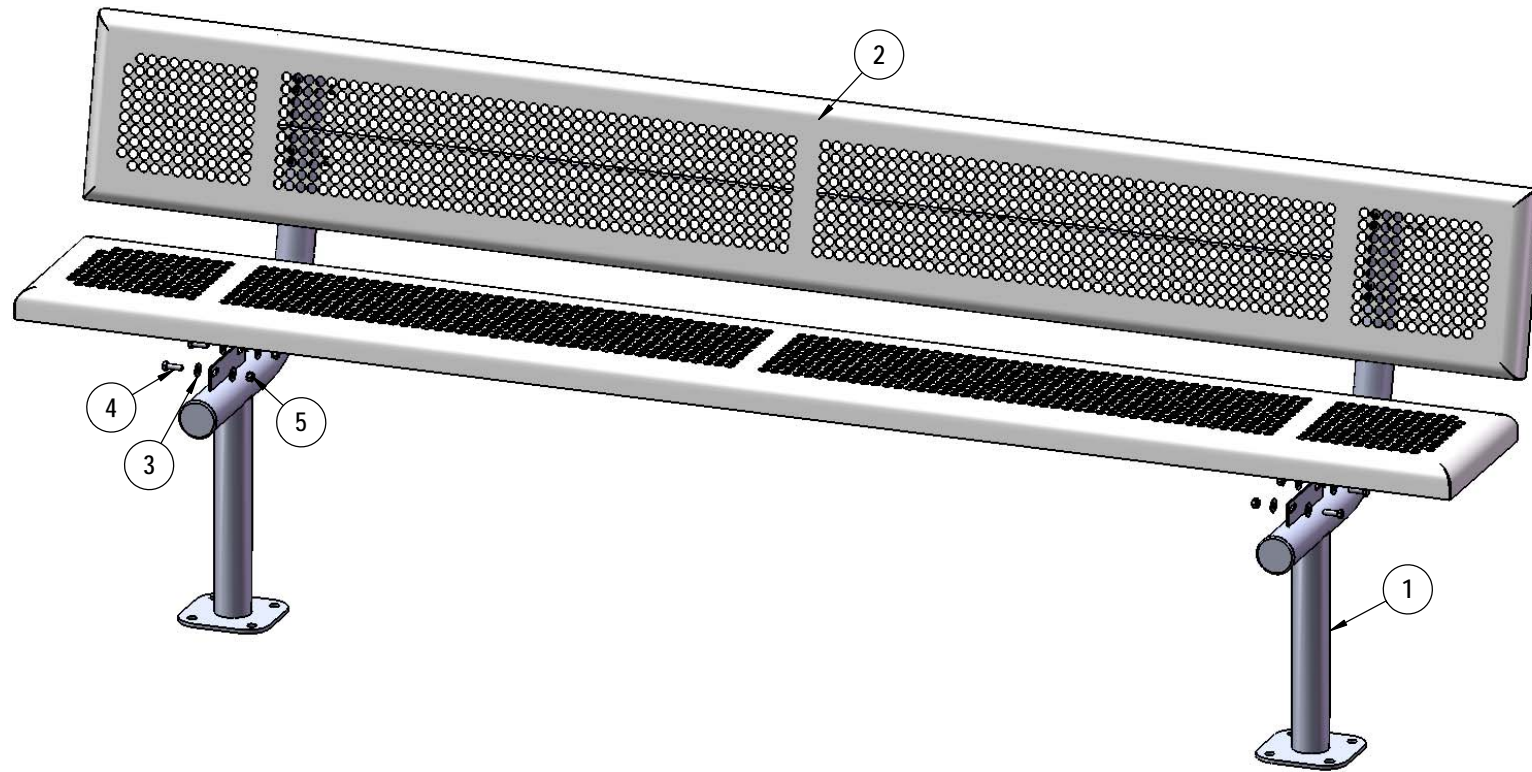

ITEM NO.	PartNo	DESCRIPTION	QTY.
1	P-V940SM	940 Surface Mount Leg	2
2	T-PR96-S	8' Punched Rolled Seat	2
3	33-02-0007	5/16" SS Washer	16
4	33-05-0029	5/16" x 1" Machine Bolt (SS)	8
5	33-03-0012	5/16" Kep Nut (SS)	8

Recommended Surface Mount Hardware:
 3/8" x 3-1/2" Concrete Expansion Anchor Bolts
 (Not Included)



OVERALL DIMENSIONS

