

Model # B8WBRN

# HARDWARE

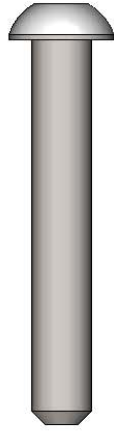

5/16" x 2"  
Button Head Bolt

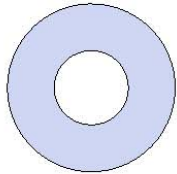

5/16" Washer

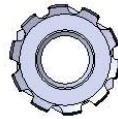

5/16" Kep Nut

## TOOLS REQUIRED

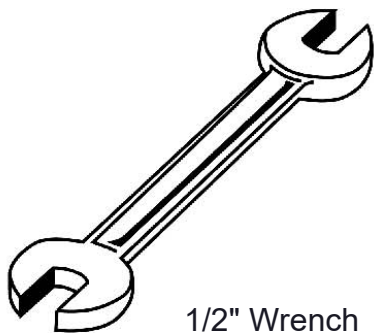

1/2" Wrench

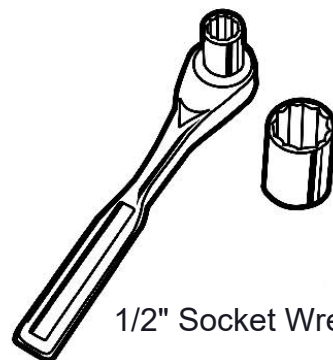

1/2" Socket Wrench

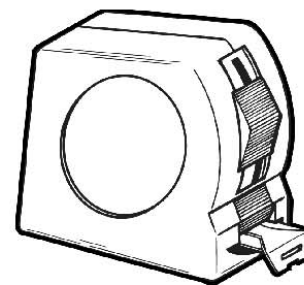

Tape Measure

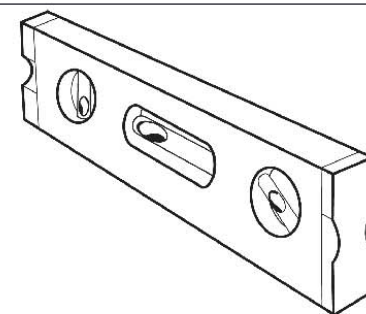

Level

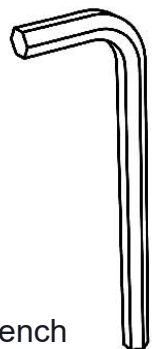

1/2" Allen Wrench

# PRODUCT SPECIFICATIONS

## **B8WBRN 8' Rainier Bench with Back**

**Seats:** Seats dimensions are 16" x 26" x 96". 12 gauge die formed flat steel plate with precision punched design. End plates are made of 10 gauge flat steel plate. Reinforced with 3/16 x 1-1/2" flat strip and 1" sch 40 Pipe. Electrically MIG welded.

**Frame:** Legs are cast aluminum.

**Seat & Frame Coating:** Steel is sandblasted to near white condition. Coated with zinc rich epoxy primer and top coated with electrostatic powdercoat, oven cured.

**Hardware:** All stainless steel hardware fasteners.

**Dimensions:** 8' portable/surface mount bench with back. Seat is 26" wide x 96" long. Seat height is 18" from the ground to the top of the seat. The overall dimensions are 32-5/16" x 29" x 100".

# COMPONENTS

Attach the 8' Contour Seat to the 974 Legs using the specified hardware.

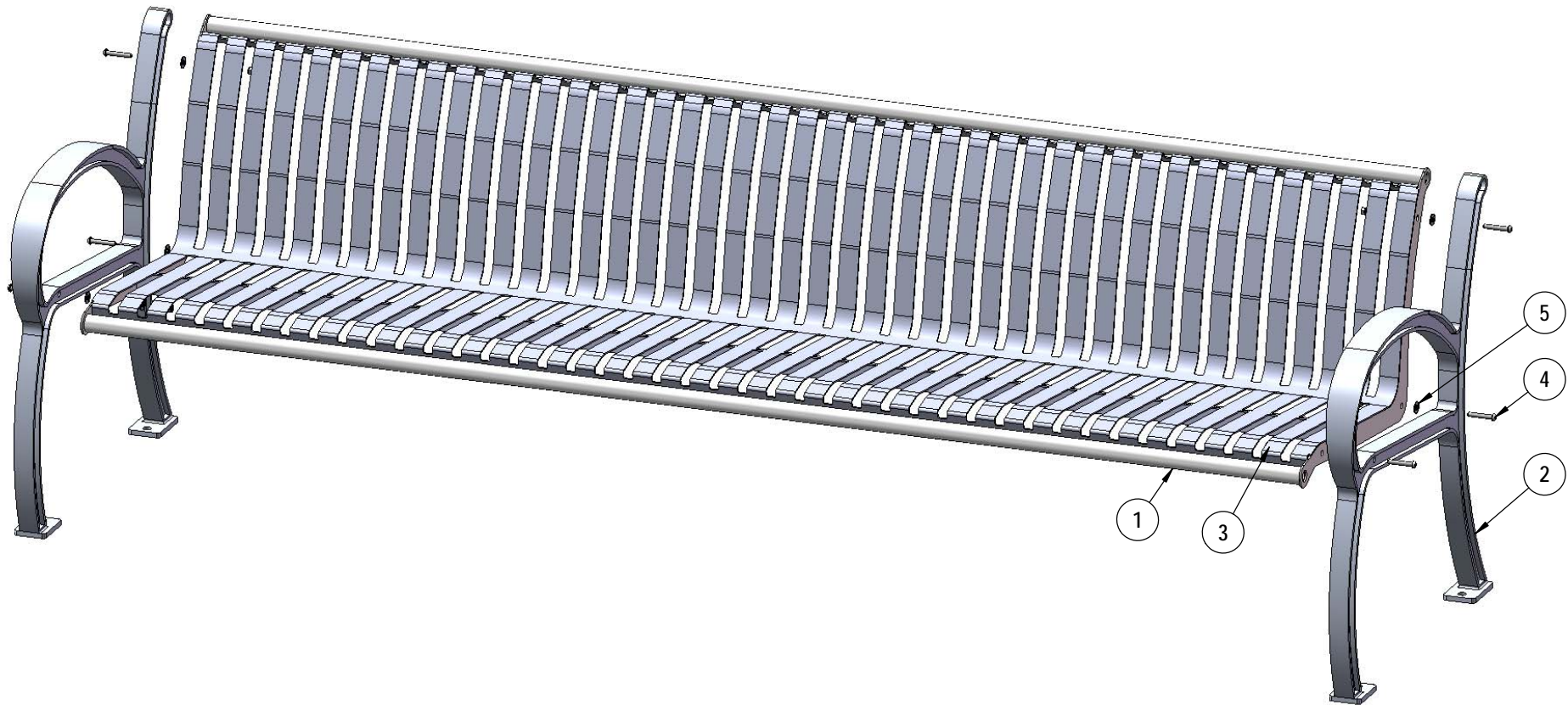

ITEM NO.	PartNo	DESCRIPTION	Qty.
1	01-01-0607	8' Slat Wilmington Contour Seat	1
2	11-01-CAST5	974 Casted Aluminum Bench Frame	2
3	33-03-0012	5/16" Kep Nut (SS)	6
4	P-33-06-0125	5/16"-18 x 2" Button Head Bolt (SS)	6
5	33-02-0007	5/16" SS Washer	12

**Superior**<sup>®</sup>  
 RECREATIONAL PRODUCTS  
A PLAYCORE Company

# OVERALL DIMENSIONS

