

Site Amenities

BY SUPERIOR RECREATIONAL PRODUCTS

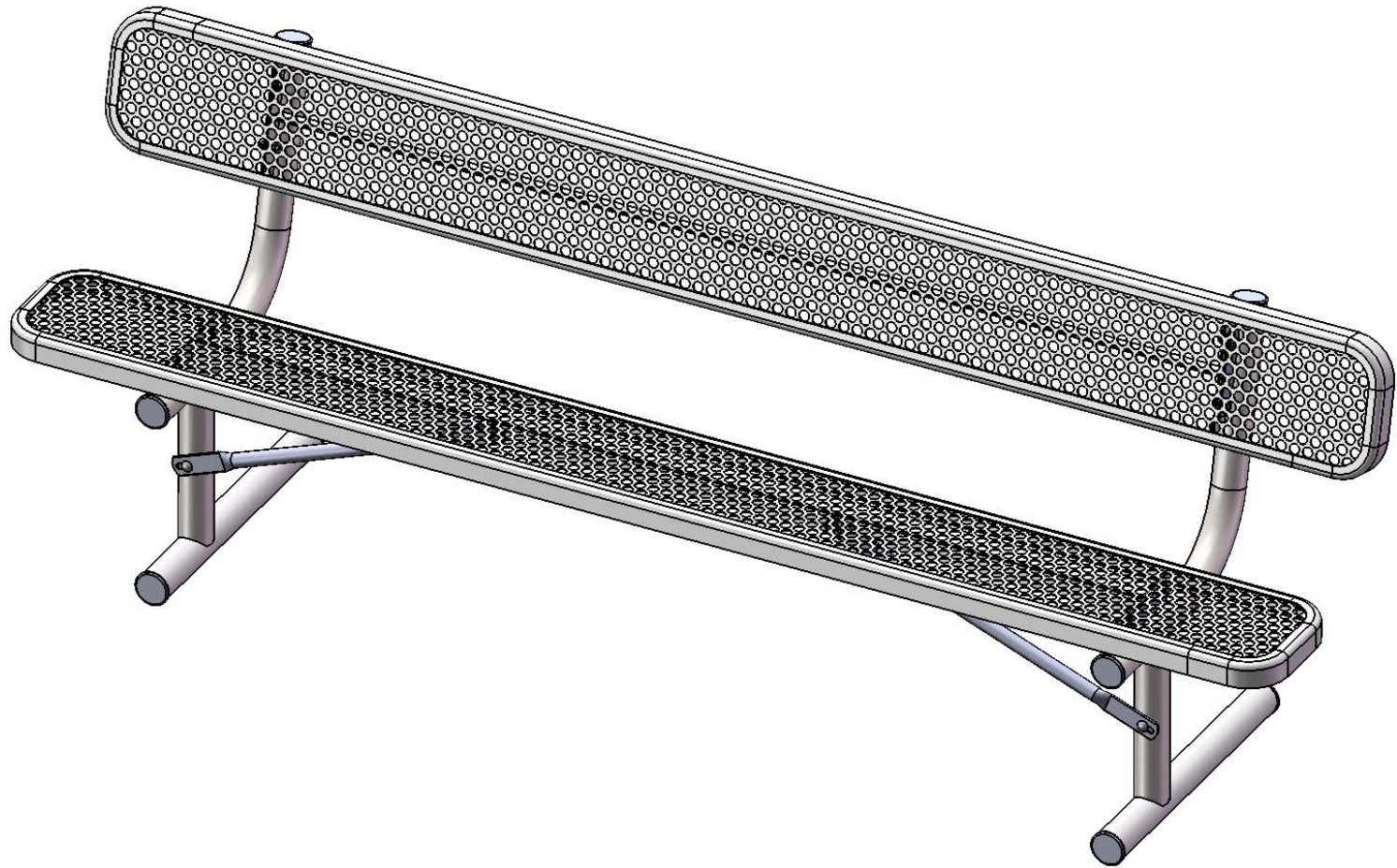

Model #
B8WBULPERFP

S SUPERIOR[®]
RECREATIONAL PRODUCTS
A PLAYCORE Company

HARDWARE

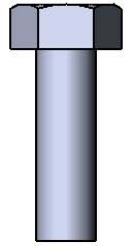

5/16" x 1"
Machine Bolt

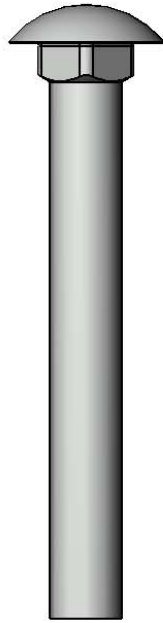

3/8" x 3"
Carriage Bolt

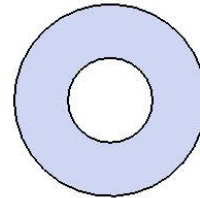

3/8" Washer

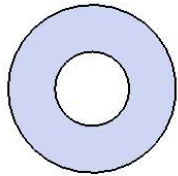

5/16" Washer

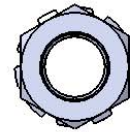

3/8" Kep Nut

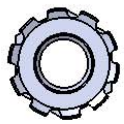

5/16" Kep Nut

PRODUCT SPECIFICATIONS

B8WBULPERFP PORTABLE BENCH WITH BACK

Seats & Back: 11 gauge die formed angle frame 1"x1-7/8" with 3" radius corners. A 14 gauge piece of sheet steel is precision punched with a 3/4" hole to create the punched hole pattern. The understructure/attachment plates are fabricated from 10 gauge x 1-1/2" flat bar. Electrically MIG welded.

Coating: Oven fused functionalized polyethylene copolymer-based thermoplastic. Fluidized bed coating application with superior mechanical performance, impact resistance and UV-stability.

Frame: 2-3/8" O.D. x 12 gauge pre-galvanized structural steel tubing. Seat/back support is bent over a mandrel through the bend radius producing a wrinkle free bend. Tube ends are pre-galvanized steel capped. Seat mounting points are 7 gauge x 1-1/2" die stamped steel flat bar. Cross braces are 1" O.D. x 16 gauge pre-galvanized structural steel tubing. All electrically MIG welded.

Frame Coating: Electrostatic powder coated application oven cured.

Hardware: All stainless steel hardware fasteners.

Dimensions: 8' bench portable with back. Seats and backs are 10" wide x 96" long. Seat height is 18", seat back height is 34-1/4". Total depth of seat with back is 22-3/8".

COMPONENTS

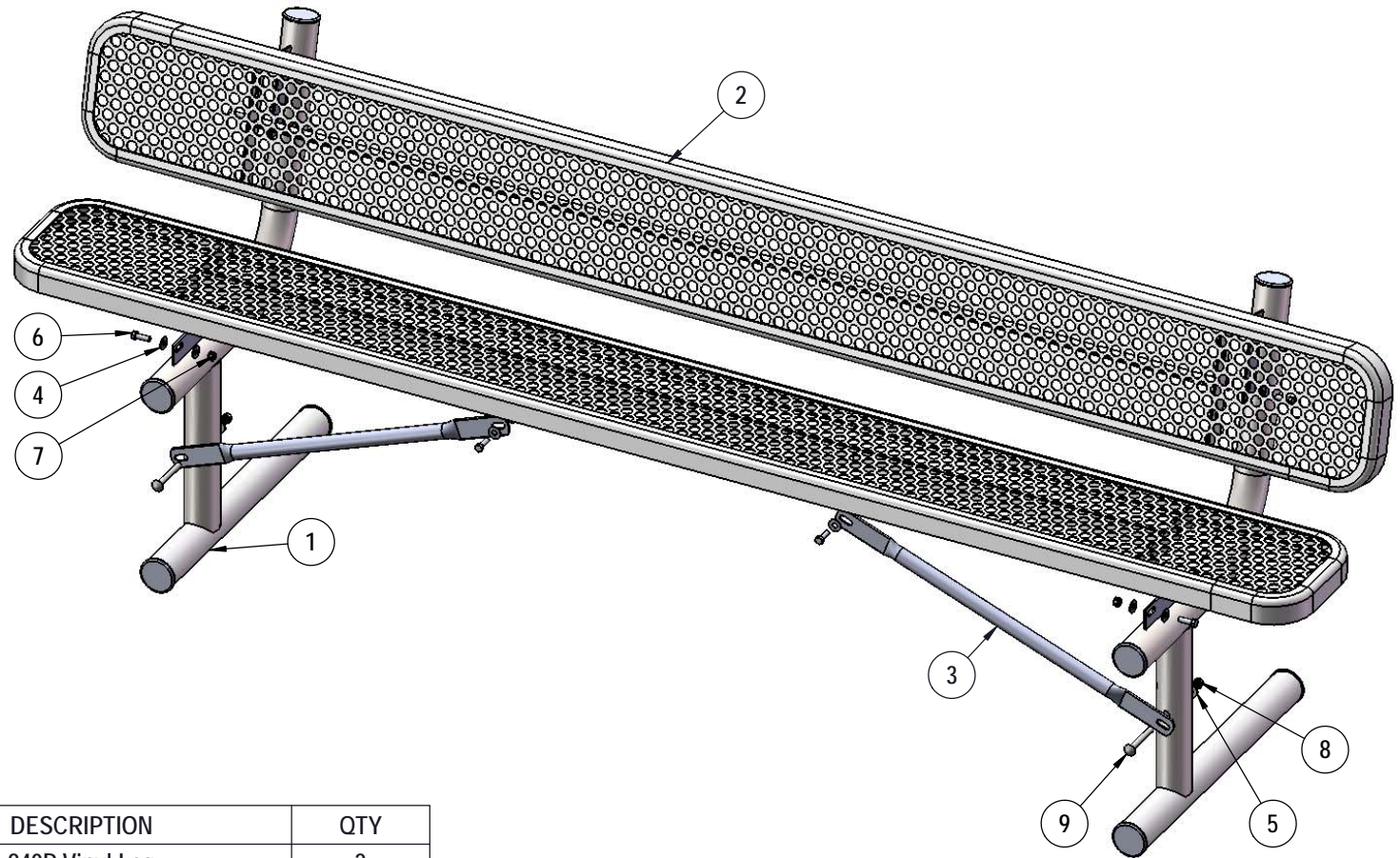

ITEM NO.	PartNo	DESCRIPTION	QTY
1	P-V940P	940P Vinyl Leg	2
2	T-EP96-S	8' x 10" perf seat	2
3	P-01-04-0129	26 3/4" Brace	2
4	33-02-0007	5/16" SS Washer	20
5	33-02-0008	3/8" Flat Washer (SS)	2
6	33-05-0029	5/16" x 1" Machine Bolt (SS)	10
7	33-03-0012	5/16" Keps Nut (SS)	10
8	33-03-0013	3/8" Keps Nut (SS)	2
9	33-06-0058	3/8" x 3" Carriage Bolt (SS)	2

STEP 1

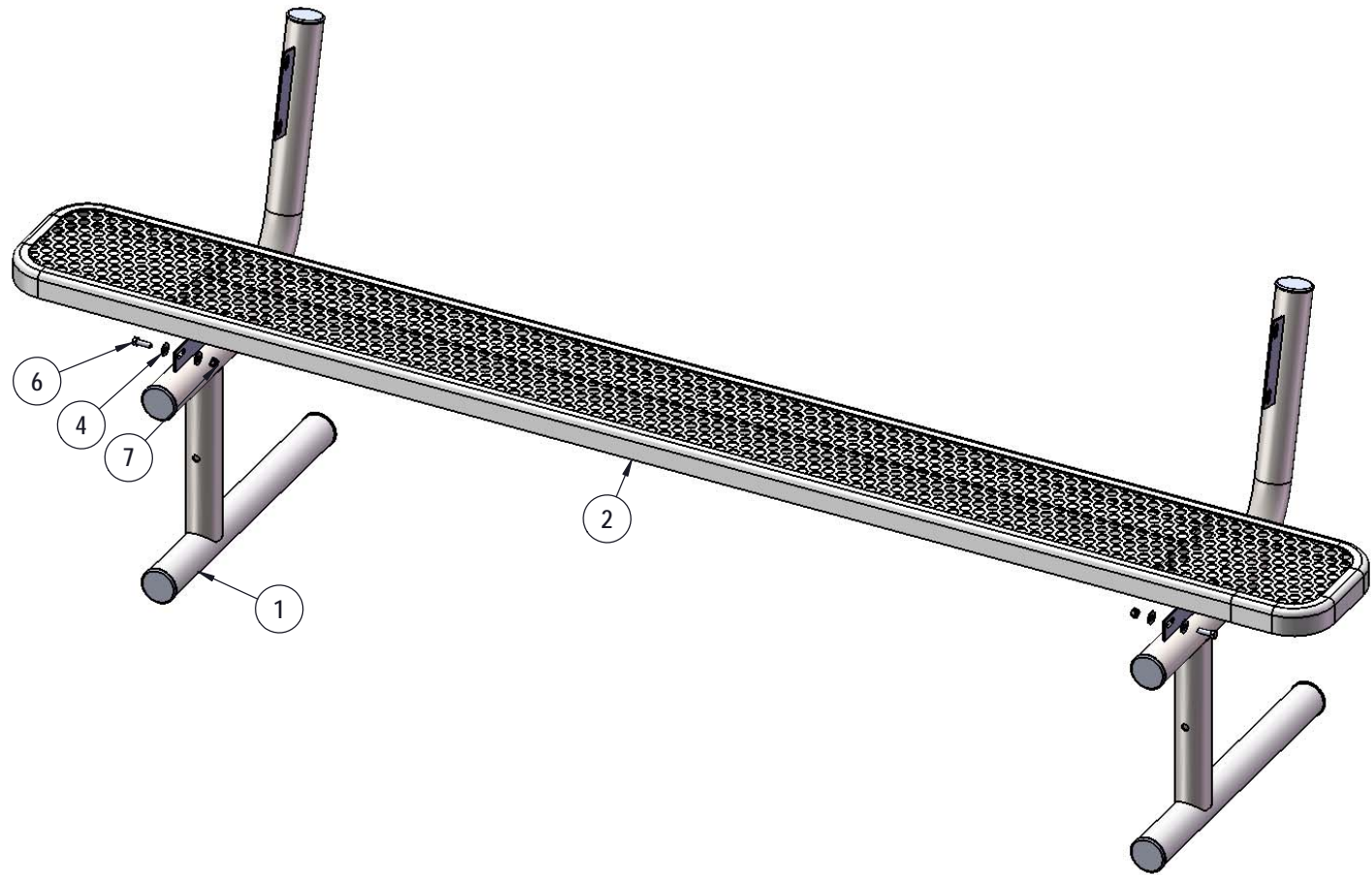

Attach the seat plank to the Legs using specified hardware.

STEP 2

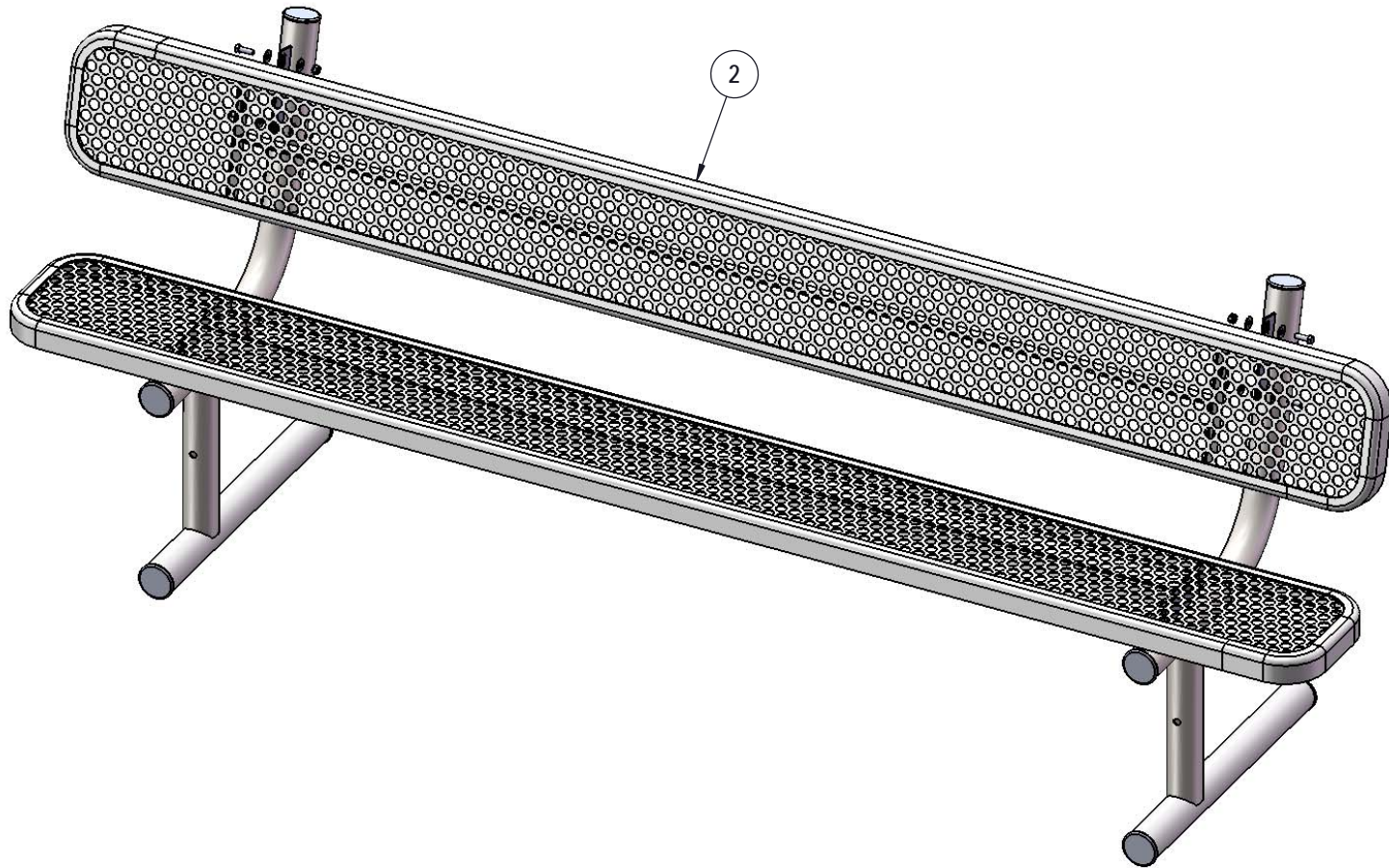

Repeat step 1 for the back.

STEP 3

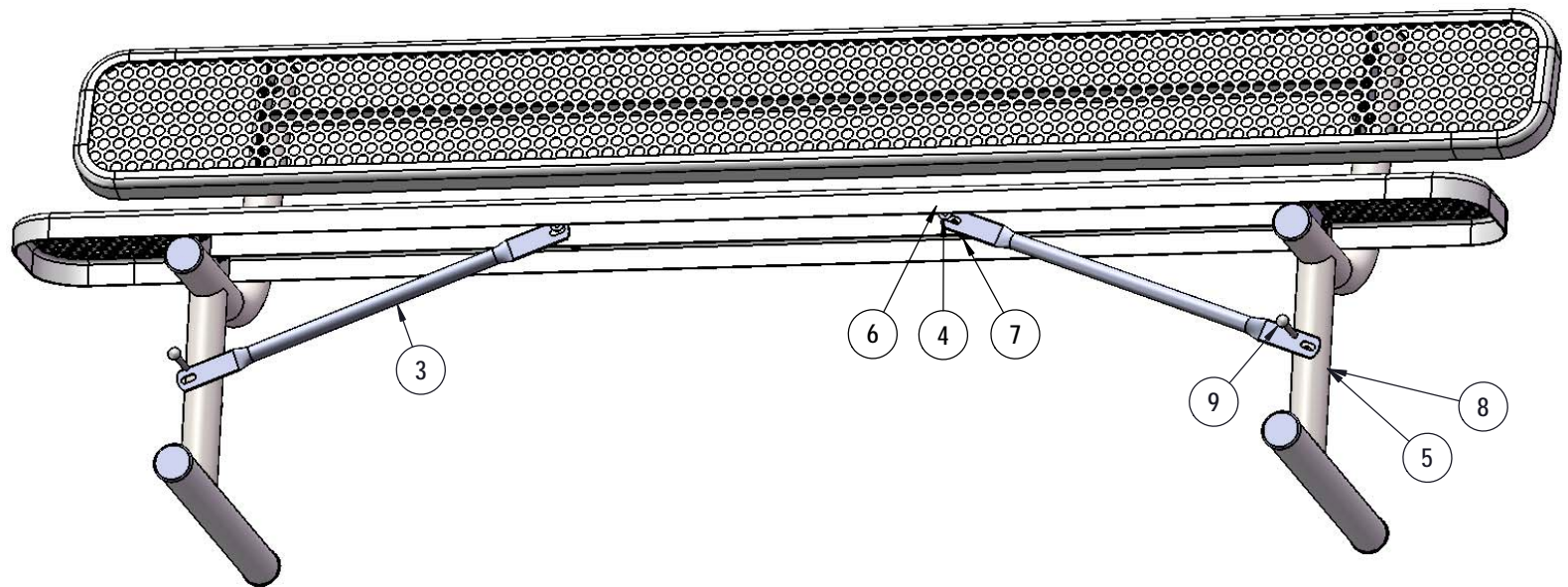

Attach the 26 3/4" Braces to the legs as shown using specified hardware.

OVERALL DIMENSIONS

