

INSTALLATION INSTRUCTIONS:

- A- PROVIDE 30" SQUARE MINIMUM x 6" DEEP MINIMUM CONCRETE SLAB BY OTHERS TO SECURELY ANCHOR FIXTURE. INSTALL THE FOUR PROVIDED CONCRETE ANCHORS (1) AT DIMENSIONS SHOWN TO MATCH HOLES (2) IN FIXTURE BASE.
- B- ROUGH-IN WASTE OUTLET (3) AT DIMENSION SHOWN FOR 1-1/4" PVC PIPE SIZE OR USE THE COMPRESSION ADAPTER PROVIDED LOOSE FOR 1-1/4" OUTER DIAMETER TUBE.
- C- ROUGH-IN WATER SUPPLY (4) WITHIN 6" DIAMETER BOTTOM OPENING FOR 1/4" NOMINAL (3/8" O.D.) x 4" LONG COPPER TUBE CONNECTED TO IN-LINE STRAINER (5) PROVIDED. STOP RECOMMENDED ON SUPPLY TO BE SUPPLIED BY OTHERS.
- D- CAREFULLY REMOVE THE FIXTURE AND COMPONENTS FROM THE PACKAGING PREVENTING SCRATCHING AND DAMAGE.
- E- REMOVE BACK ACCESS PANEL (6) FROM FIXTURE PEDESTAL (7) AND BOTTOM ACCESS PANEL (8) FROM CANTILEVER (9). ENSURE PUSHBUTTONS (10), WASTE PIPING (11), AND BUBBLERS (12) ARE SECURE AND CHECK ALL THE TUBING CONNECTIONS TO MAKE SURE THEY DID NOT COME LOOSE IN SHIPMENT.
- F- SET PEDESTAL (7) IN PLACE ALIGNING BASE HOLES (2) WITH THE INSTALLED ANCHORS (1) AND SECURE WITH THE 1/2" UNC HARDWARE (13) PROVIDED.
- G- MAKE-UP WASTE CONNECTION TO THE WASTE PIPING (11).
- H- FLUSH WATER SUPPLY (4) BY OTHERS OF ALL DEBRIS PRIOR TO CONNECTING TO FIXTURE.
- I- CONNECT WATER SUPPLY (4) BY OTHERS TO 1/4" NOMINAL COPPER TUBE INLET. STOP ON THE SUPPLY IS RECOMMENDED.
- J- TEST OPERATION OF BUBBLERS BY DEPRESSING BUTTONS (10). ADJUST THE FLOW RATE AS REQUIRED. SEE DETAIL A. CHECK ALL CONNECTIONS AND WASTE PIPING FOR LEAKS. CORRECT IF PRESENT.
- K- RE-INSTALL BACK ACCESS PANEL (6) AND BOTTOM ACCESS PANEL (8).

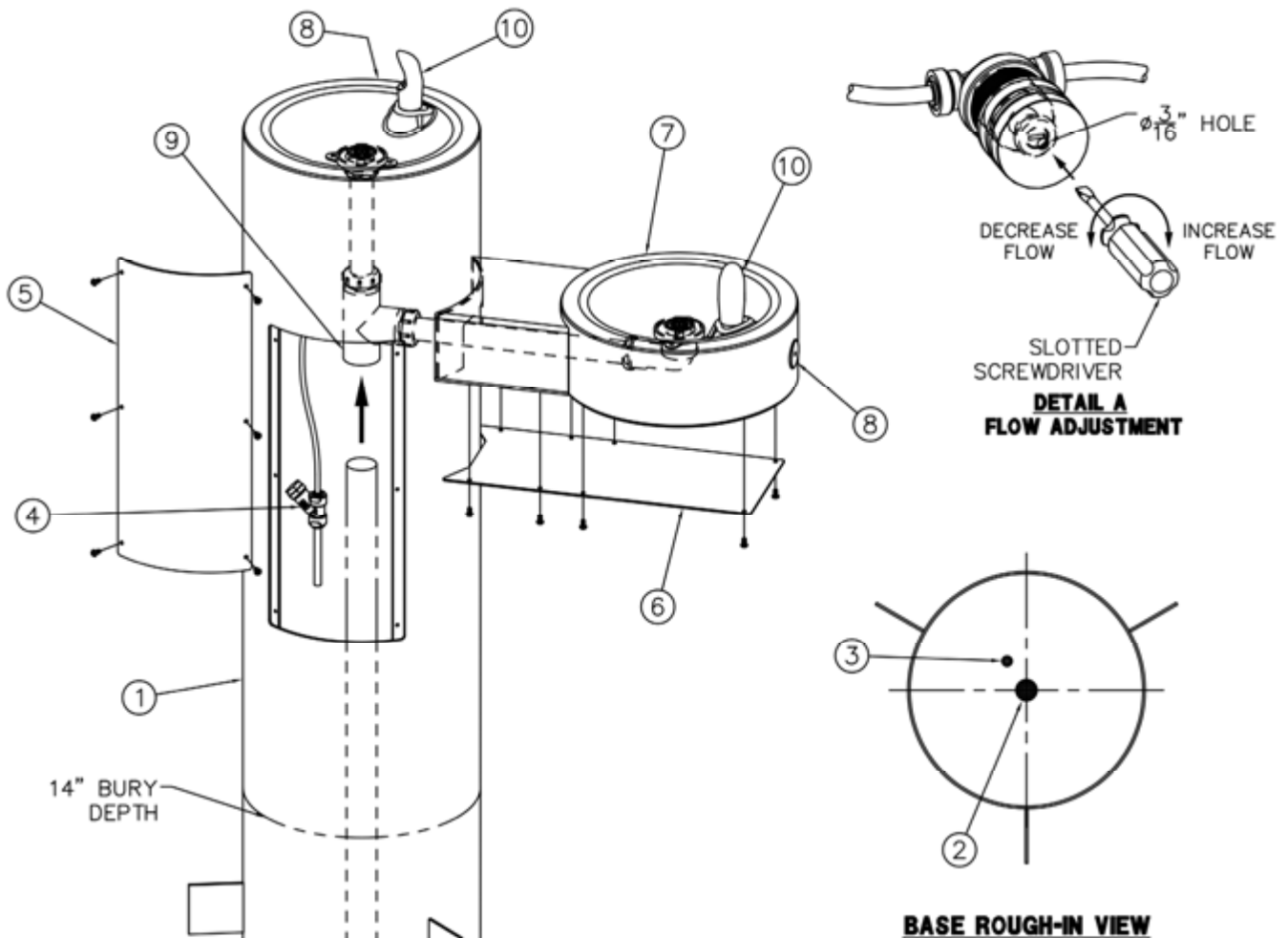

INSTALLATION INSTRUCTIONS:

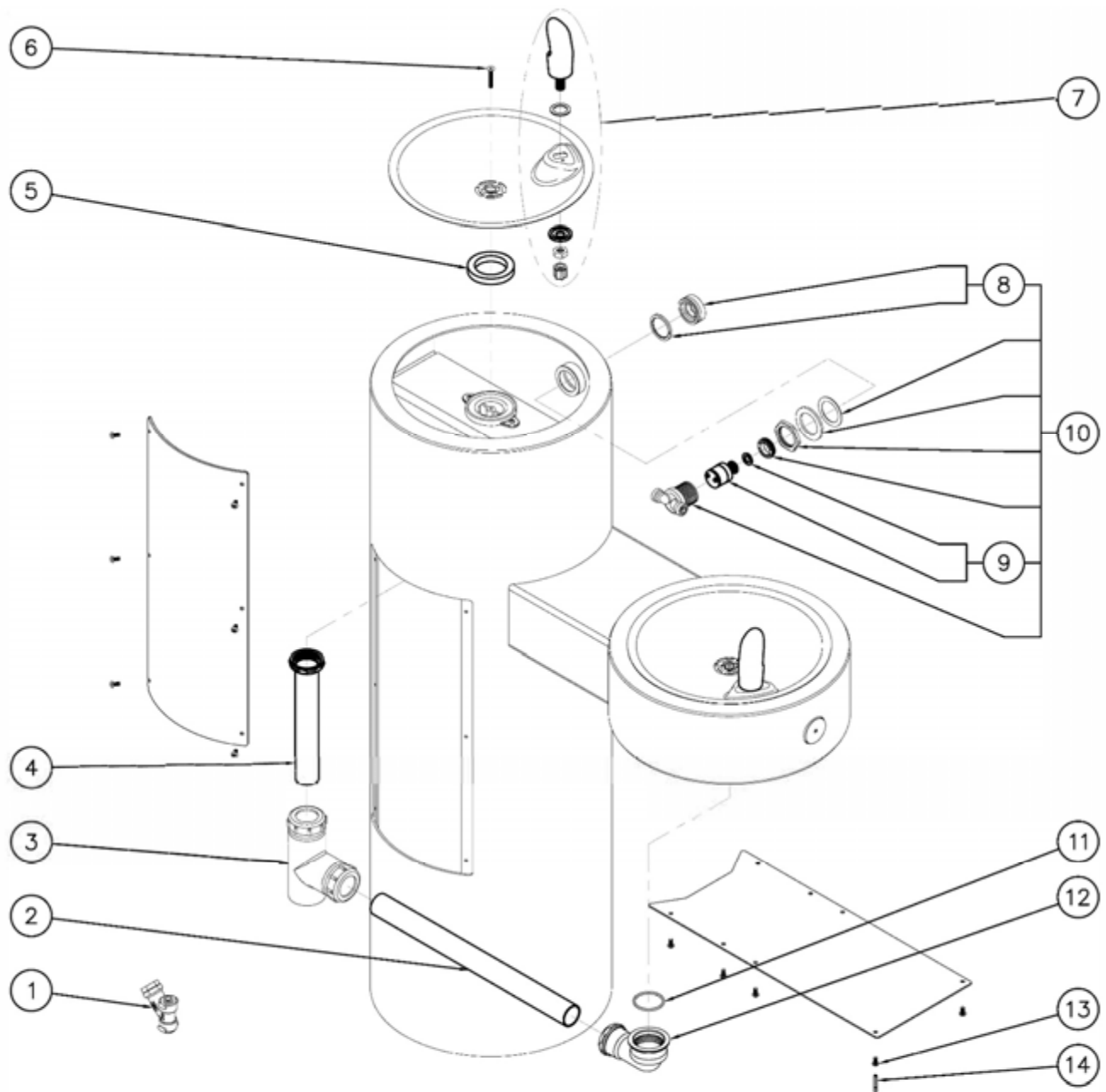

- A- PREPARE INSTALLATION LOCATION TO BURY FIXTURE PEDESTAL ① TO 14" DEPTH.
- B- ROUGH-IN WASTE OUTLET ② CENTERED AS SHOWN FOR 1-1/4" PVC PIPE SIZE OR USE THE COMPRESSION ADAPTER PROVIDED LOOSE FOR 1-1/4" OUTER DIAMETER TUBE.
- C- ROUGH-IN WATER SUPPLY ③ FOR 1/4" NOMINAL(3/8" O.D.) X 4" LONG COPPER TUBE CONNECTED TO IN-LINE STRAINER ④ PROVIDED. RECOMMENDED SUPPLY STOP BY OTHERS.
- D- CAREFULLY REMOVE THE FIXTURE AND COMPONENTS FROM THE PACKAGING PREVENTING SCRATCHING AND DAMAGE.

- E- SET FIXTURE IN PLACE TO 14" BURY DEPTH. ENSURE IT IS VERTICAL ALL AROUND. POUR CONCRETE. ALLOW TO CURE.
- F- REMOVE BACK ACCESS PANEL ⑤ FROM FIXTURE PEDESTAL ① AND BOTTOM ACCESS PANELS ⑥ FROM CANTILEVERS ⑦. ENSURE PUSHBUTTONS ⑧, WASTE PIPING ⑨, AND BUBBLERS ⑩ ARE SECURE AND CHECK ALL THE TUBING CONNECTIONS TO MAKE SURE THEY DID NOT COME LOOSE IN SHIPMENT.
- G- MAKE-UP WASTE CONNECTION TO THE WASTE PIPING ⑨.
- H- FLUSH WATER SUPPLY ③ BY OTHERS OF ALL DEBRIS PRIOR TO CONNECTING TO FIXTURE.
- I- CONNECT WATER SUPPLY ③ BY OTHERS TO 1/4" NOMINAL COPPER TUBE INLET. STOP ON THE SUPPLY IS RECOMMENDED.
- J- TEST OPERATION OF BUBBLERS BY DEPRESSING BUTTONS ⑧. ADJUST THE FLOW RATE AS REQUIRED. SEE **DETAIL A**. CHECK ALL CONNECTIONS AND WASTE PIPING FOR LEAKS. CORRECT IF PRESENT.
- K- RE-INSTALL BACK ACCESS PANEL ⑤ AND BOTTOM ACCESS PANELS ⑥.

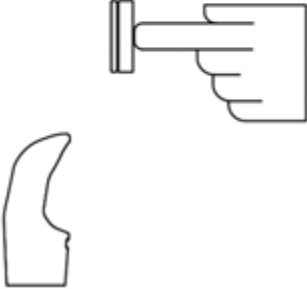

1	7000-021-001	"Y" STRAINER	8	7000-068-001	RETAINING RING AND BUTTON ASSEMBLY
2	7000-111-199	1-1/4" O.D. x 14" LONG DRAIN TUBE	9	7000-050-001	VALVE CARTRIDGE
3	7002-011-001	BI-LEVEL TEE ASSEMBLY	10	7000-065-001	RECESSED PUSHBUTTON VALVE ASSEMBLY
4	7000-019-001	1-1/4" OUTER DIAMETER TAILPIECE	11	0401-128-000	O-RING
5	7000-006-000	FLAT DRAIN ADAPTER GASKET	12	7000-017-001	ELBOW ASSEMBLY
6	0152-010-000	CENTER REJECT ALLEN FLAT HEAD SCREW	13	0112-001-000	CENTER REJECT ALLEN BUTTON HD SCREW
7	7000-012-001	STAINLESS STEEL BUBBLER	14	0296-025-199	CENTER REJECT HEX DRIVER BIT
ITEM	PART NUMBER	DESCRIPTION	ITEM	PART NUMBER	DESCRIPTION

STANDARD PUSH PAD / PUSH BUTTON DRINKING FOUNTAIN

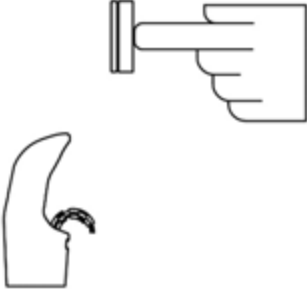
CONDITION:	SOLUTION:
<p>NO WATER FLOW:</p> 	<ol style="list-style-type: none"> 1.1 Check water main supply – open. 1.2 Inspect stop (by others) – open & no debris. 1.3 Inspect in-line strainer for debris – clean. 1.4 Replace valve cartridge.
<p>WATER DRIPS / WILL NOT SHUT OFF:</p> 	<ol style="list-style-type: none"> 2.1 For push pad activated drinking fountains only: Open fixture and move valve bracket assembly further back from push pad. 2.2 Replace valve cartridge.
<p>REDUCED WATER FLOW:</p> 	<ol style="list-style-type: none"> 3.1 Adjust the valve flow rate. See appropriate fixture installation instructions. 3.2 Check water main supply for 20 psig minimum flow pressure. 3.3 Inspect stop (by others) – open & no debris. 3.4 Inspect in-line strainer for debris – clean. 3.5 Inspect bubbler for debris – clean. 3.6 Inspect all tubing for twists or kinks. 3.7 Replace valve cartridge.

Important: Read all instructions and refer to local codes prior to installation.

- Local soil conditions may require more gravel for drainage.
- It is recommended to include a supply stop appropriate located on the supply line.
- A in-line PRV installed on the supply line is recommended to ensure a working water pressure of 40-60 psi.
- A water filter should be installed on the supply line if sediment or mineral content is a problem.
- Supply line must flushed of all foreign materials such as pipe dope, chips, etc.
- Piping and valve must be drained prior to being subjected to freezing temperatures.

Prepare trench for water supply lines and waste line (if required). At fountain location prepare hole to trench depth and large enough for a person to work in. Lay supply and waste into trench and above ground allowing extra line to be trimmed during hook up, refer to details for roughs.

Depending on code and design requirements, drain may be open, French or sanitary connection. For french drain, place a minimum of three cubic feet of gravel under drain opening. Local soil conditions may require more gravel drainage.

Refill trench and hole, compacting back fill as required. Leave sufficient depth in hole to accommodate concrete pour, 4" minimum recommended.

Prepare slab area surrounding fountain spreading and compacting gravel as necessary. Prepare form approximately 6" diameter to protect supply and waste stub outs. Protect exposed valve assembly, tubing and tube openings to prevent damage to equipment or to prevent tubes from becoming filled with soil or debris. Then pour concrete, ensure concrete is flat and level.

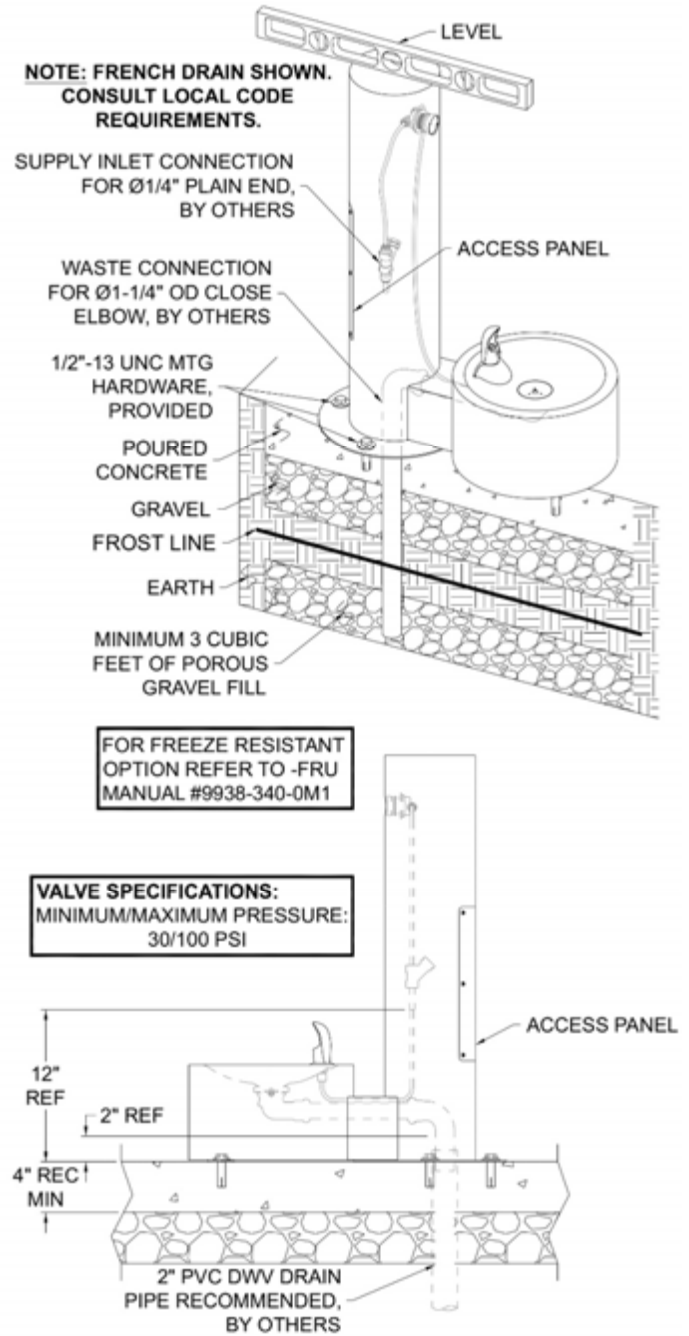

Once concrete has cured, drill 3/4" diameter by 2" deep holes following the pattern shown in the mounting base detail for the provided drop-in anchors. Using the anchor setting tool, hammer the provided drop-in anchors into the drilled holes. Align mounting points on the fountain to the mounting anchors in the concrete and secure the fixture to the slab using the provided mounting hardware.

Through access panel make up connections to fountain's 3/8" OD (1/4" nominal) plain end supply inlet and 1-1/4" OD close elbow waste outlet.

To ensure plumb installation, lay a bubble level on fountain bowl and adjust using shims or washers until the unit is level. To test operation of bubbler, depress the activation pushbutton and adjust flow rate as required and check all connections for leaks.

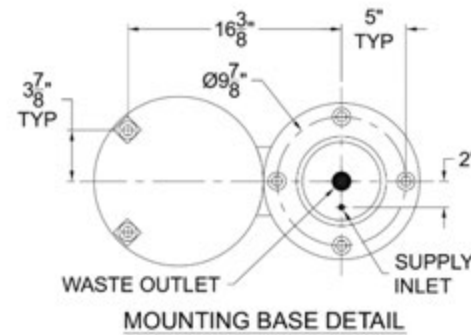

MAINTENANCE

All normal maintenance is done from above the ground.

- ❖ Always shut off water supply when doing any maintenance.
- ❖ **To remove pedestal mounted pushbutton assembly** remove access panel. From inside of the pedestal, remove inlet and outlet lines from push-in ports of the valve body. Using a spanner wrench remove pushbutton and retaining ring.
- ❖ **To replace regulator**, use a spanner wrench to remove pushbutton and retaining ring from the flange collar. Use a spanner wrench to remove retainer from the inside of the flange collar. Remove regulator, insert new regulator and align ports to new regulator with mating ports of valve body then replace retaining ring.
- ❖ **Re-assemble in reverse order.** When replacing inlet and outlet line ensure to insert supply line into valve port labeled "IN". Ensure that plastic line is not kinked when fountain is re-assembled.

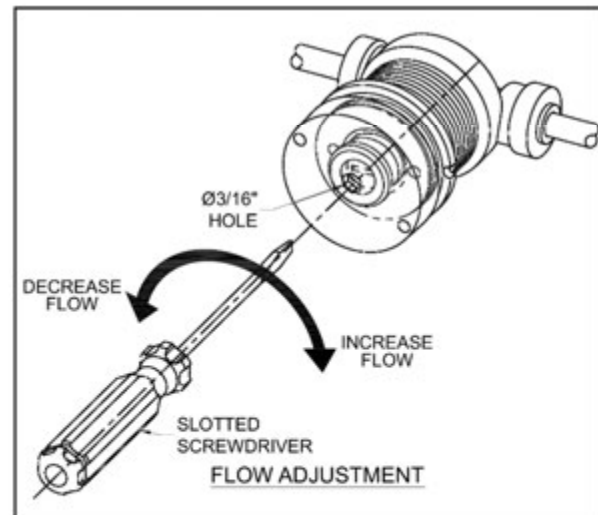
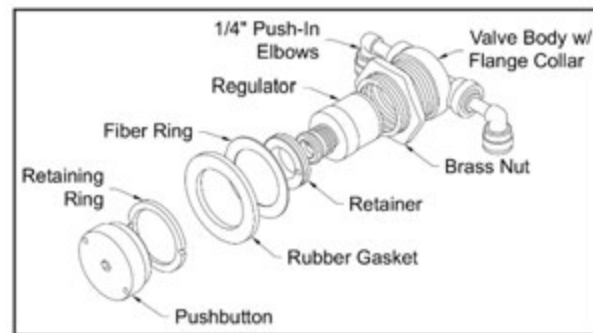

The water flow can be adjusted using a slotted narrow blade screwdriver and turning clockwise to increase flow and counterclockwise to decrease flow.

PUSH-IN FITTING INSTALLATION

NOTE: FITTINGS AND TUBE SHOULD BE KEPT CLEAN, BAGGED AND UNDAMAGED PRIOR TO INSTALLATION.

TO CUT TUBE:

Cut to fit length of 1/4" PE tubing and remove any burrs or sharp edges. Ensure that the outside diameter is free from score marks. Tube ends should be square.



INSERTING THE TUBE:

1. Firmly and fully insert the tubing end into the push-in fitting up to the tube stop located approximately 1/2" deep.

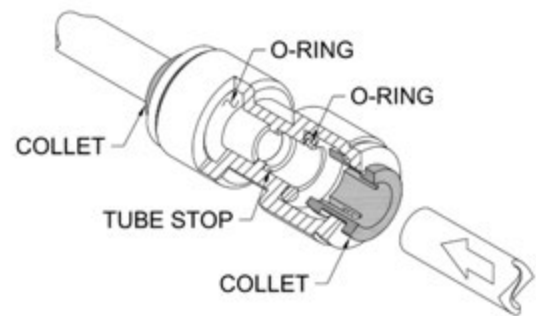

2. Pull on the fitted tubing to ensure it is secure. Tube should not come free from the fitting. Water test the connection assembly prior to leaving the site to ensure there are no leaks.

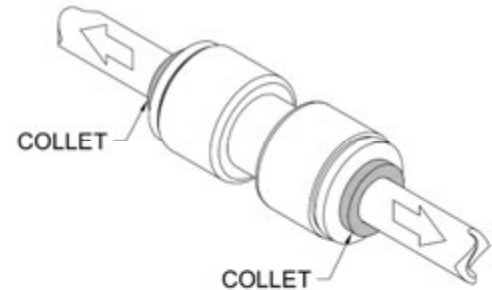

DISCONNECTING THE TUBE:

To disconnect the tube from the fitting ensure that the water line is depressurized. Push collet square towards the push-in fitting body and hold. While holding the collet in, pull on the PE tubing to remove from the push-in fitting.

