

Site Amenities

BY SUPERIOR RECREATIONAL PRODUCTS

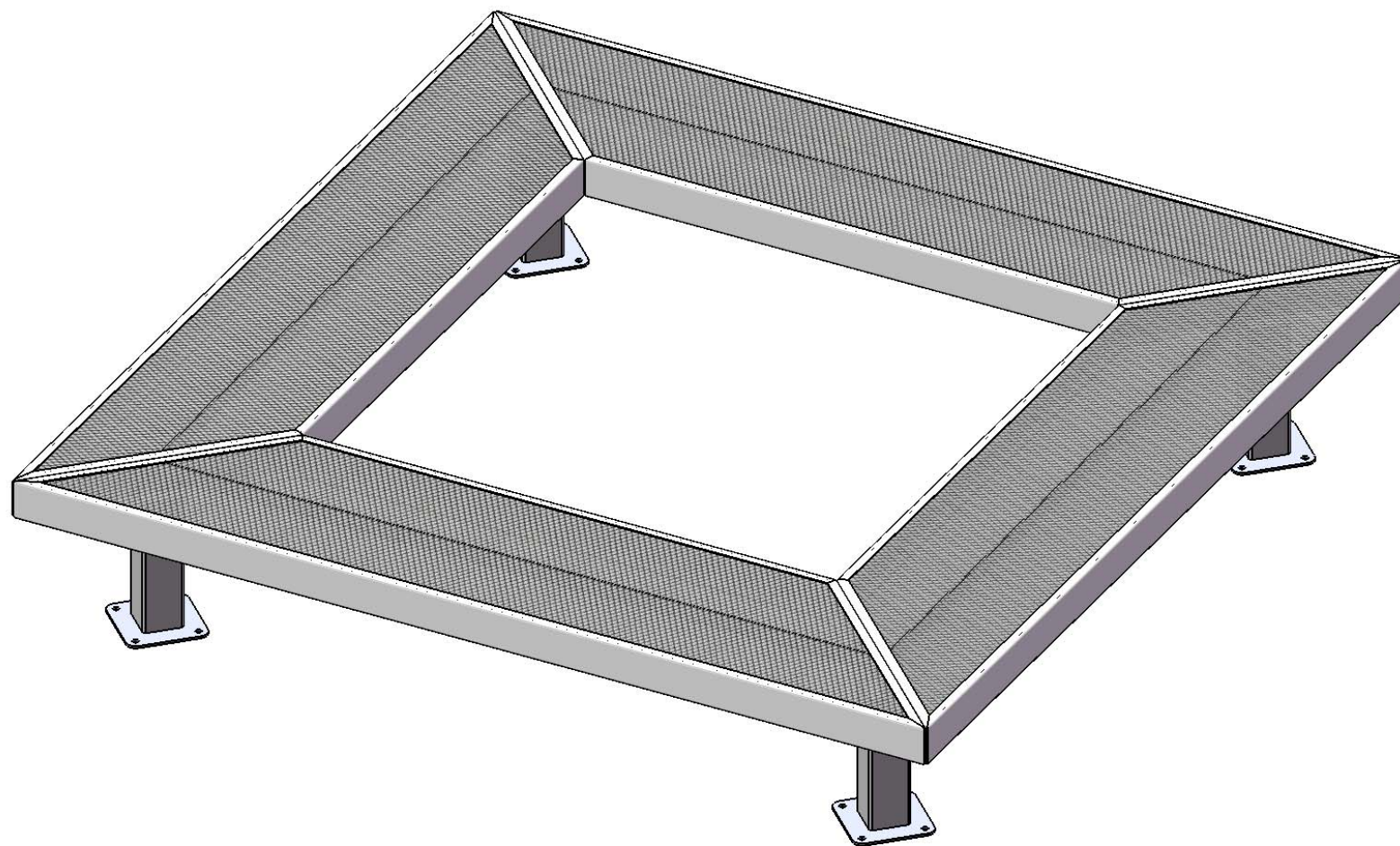

Model #
GBS96SM

 **SUPERIOR**[®]
RECREATIONAL PRODUCTS
A **PLAYCORE** Company

HARDWARE

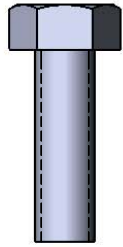

5/16" x 1"
Machine Bolt

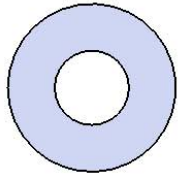

5/16" Washer

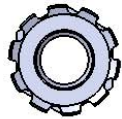

5/16" Kep Nut

PRODUCT SPECIFICATIONS

GBS96SM SURFACE MOUNT “MALL” BENCH

Seats: Side rails are formed from 14 gauge steel. 3/4" #9 steel expanded metal. 7 gauge x 1-1/2" flat bar center support and mounting bracket understructure. Electrically MIG welded.

Seat Coating: Oven fused functionalized polyethylene copolymer-based thermoplastic. Fluidized bed coating application with superior mechanical performance, impact resistance and UV-stability.

Frame: 4 x 4 x 11 gauge structural zinc coated steel square tubing. Legs are capped with a 4 x 4 x 3/16" steel flat bar. Seat and top mounting points 7 gauge x 1-1/2" die stamped steel flat bar. All electrically MIG welded.

Frame Coating: Electrostatic powder coated application oven cured.

Hardware: All stainless steel hardware fasteners.

Dimensions: 8' bench surface mount without back. Seats are 20" wide x 96-1/8" long. Seat height is 18". Creating a 96-1/8" square.

COMPONENTS

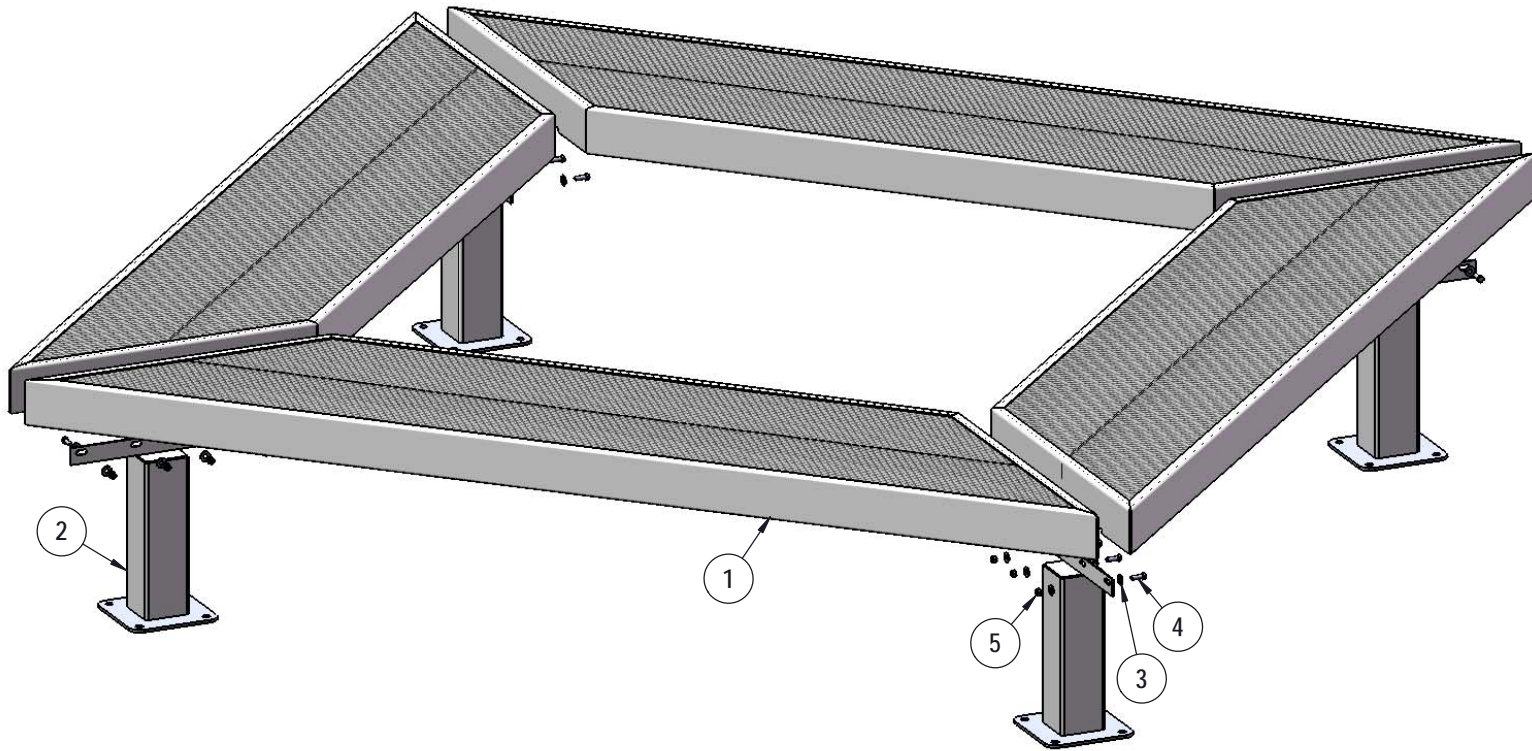

Optional Surface Mount Hardware:
 3/8" x 3-1/2" Concrete Expansion Anchor Bolts
 (Not Included)

ITEM NO.	PartNo	DESCRIPTION	QTY
1	T-V96GM-S	8' expanded geometric mall bench seat	4
2	P-V934SM	934 SM Leg	4
3	33-02-0007	5/16" SS Washer	32
4	33-05-0029	5/16" x 1" Machine Bolt (SS)	16
5	33-03-0012	5/16" Kep Nut (SS)	16

S SUPERIOR[®]
 RECREATIONAL PRODUCTS
 A PLAYCORE Company

STEP 1

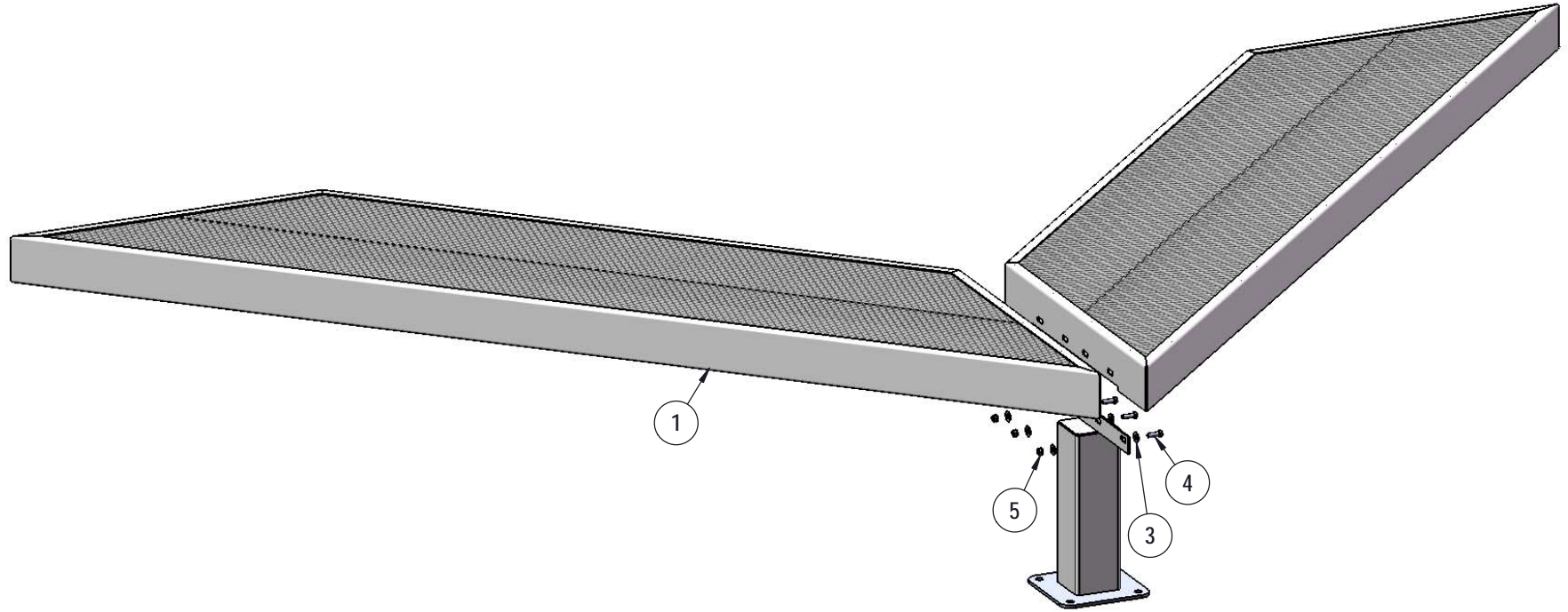

Attach two of the 8' benches to a Leg using specified hardware as shown. Repeat this using the other two benches.

STEP 2

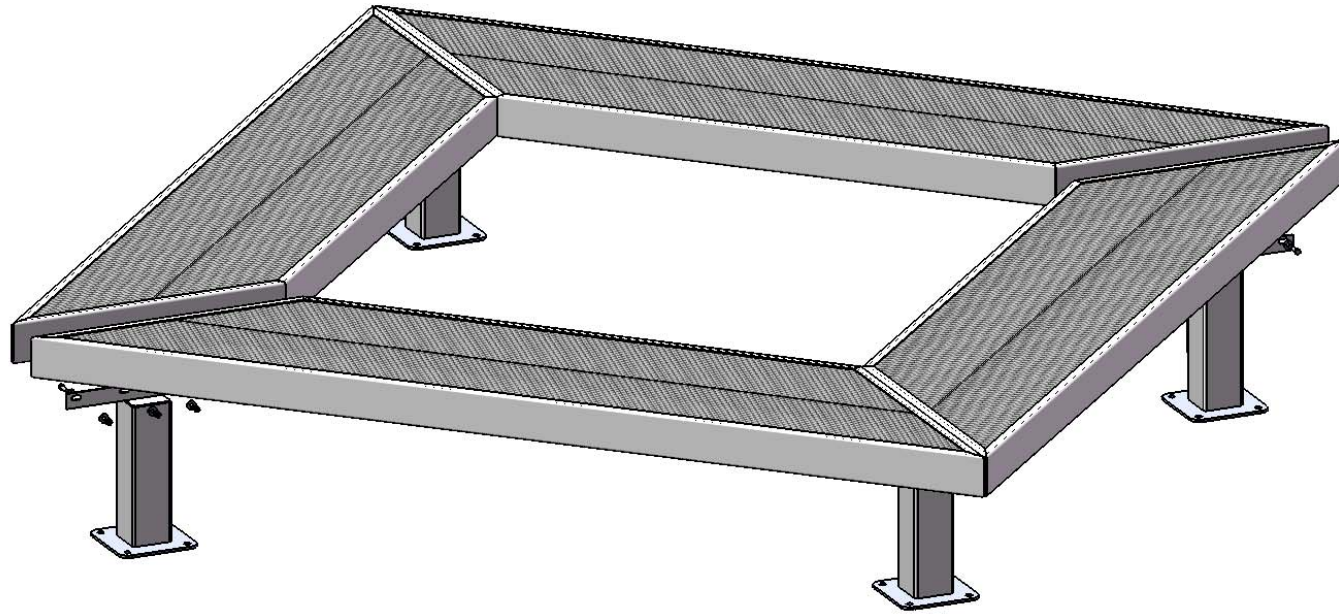

Take note of leg position.

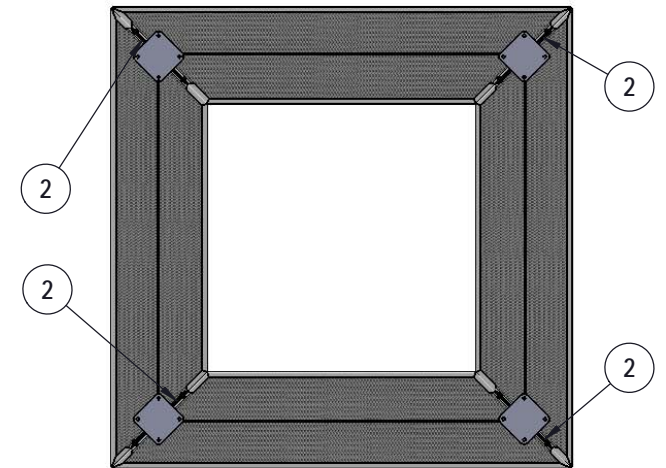

Attach the two halves of the square together using the other two legs and hardware.

OVERALL DIMENSIONS

