

Ascend Thrill Tower Drawing

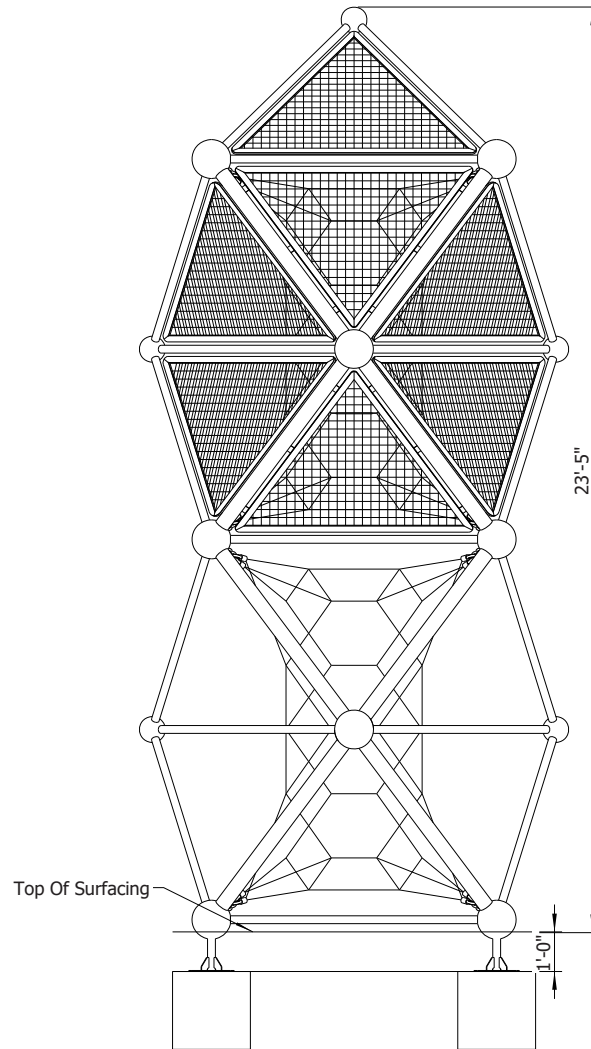

Product Name:	Ascend Thrill Tower
Model Number:	RC-X2SR
Size:	Length: 11' 3" Width: 10' 11" Height: 23' 5"
Fall Height:	10'
Foundations:	4
Concrete Volume:	1.2 cubic yards
COMPLIANT WITH:	ASTM F-1487 CSA Z614
Ages:	5-12 years
Use Zone:	Length: 23' 3" Width: 22' 11"

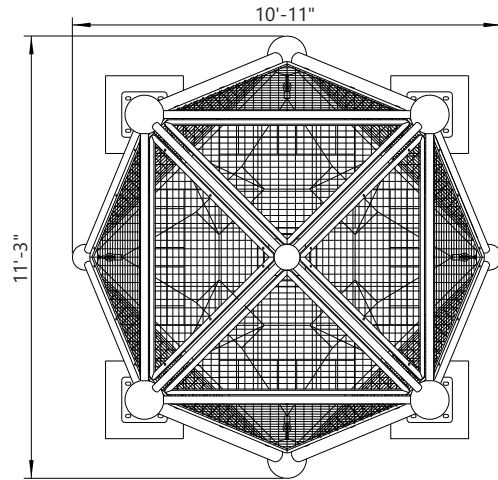
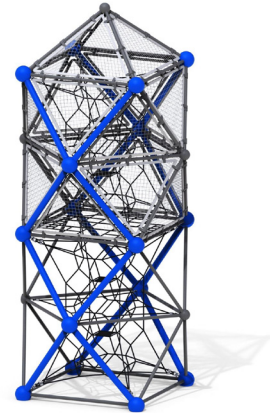

Technical Details:

Climber Frame	Main curvilinear supports shall be 4-1/2" (114 mm) diameter steel tubing combined with 2-3/8" (61mm) diameters steel tubing. After fabrication the frame shall be powder coated in accordance with the specifications herein.
Climber Pipe Junctions	8" (200mm) and 12" (300mm) diameters structural aluminum covers with integrated sleeves for pipe connections provided and shall be powder coated in accordance with the specifications herein.
Rope	20mm diameter rope consists of 6 main strands, each strand containing 24 galvanized steel reinforcing strands within a polyamide sleeve, wrapped around a solid polyamide core for a total of 144 reinforcing strands. Ropes shall achieve a Class 7-8 colorfastness rating.
Rope Ball Connectors and End Fittings	One-piece compressed aluminum ball connector or end fitting, compressed in place with 150,000 pounds source (667kN) to prevent the connection from moving and causing premature cable wear.
Decking	Shall be made from min. 3/4" (19mm) thick high density, UV-stabilized and color impregnated polyethylene.
Flexible Surfaces	5/16" (8mm) thick textile-reinforced rubber belt.
Fasteners	All fasteners shall be stainless steel with locking patch or locking compound (by others).
Rotationally molded slide and climbers	Shall be uniform construction with rotationally molded linear low-density U.V. stabilized polyethylene with a 1/4" (6mm) nominal wall thickness, available in manufacturer's standard colors.
Slide Support	Shall be fabricated 2" (50mm) galvanized steel tubing with a formed 11 gauge (3mm) steel plate and shall be powder coated in accordance with the specifications herein.
Metal Finish	Polyester (Powder) Coating – The polyester coating shall be uniformly applied by the electrostatic method to a minimum thickness of four mils. Promptly after application of the powder, the coating shall be oven-cured at 350 degrees Fahrenheit. The color(s) of the polyester coating shall be from the manufacturer's standard color selection.
Installation	Installation recommended by a licensed playground contractor, trained and certified on the applicable playground installation methods and standards, preferably certified by manufacturer or National Playground Contractors Association.
Concrete Achors	Supplied by others.