

Model # T46CLASSPEDPOR-3

HARDWARE

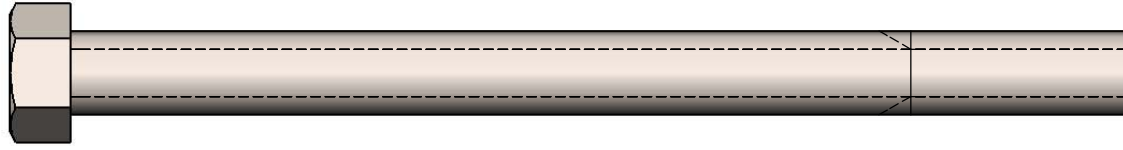

7/16" x 5-1/2"
Machine Bolt

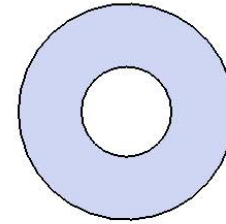

7/16" Washer

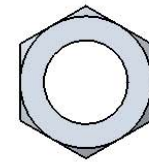

7/16" Hex Nut

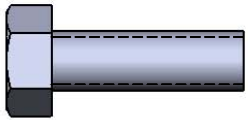

5/16" x 1"
Machine Bolt

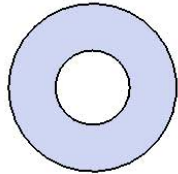

5/16" Washer

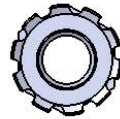

5/16" Kep Nut

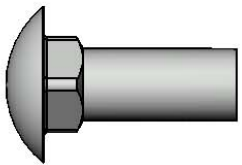

3/8" x 1"
Carriage Bolt

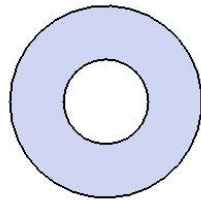

3/8" Washer

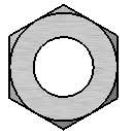

3/8" Hex Nut

TOOLS REQUIRED

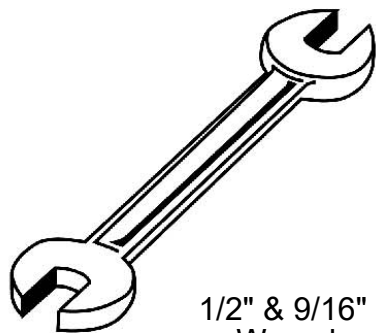

1/2" & 9/16"
Wrench



1/2" & 9/16"
Socket Wrench

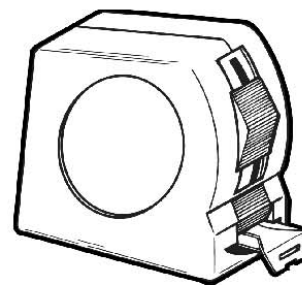

Tape Measure

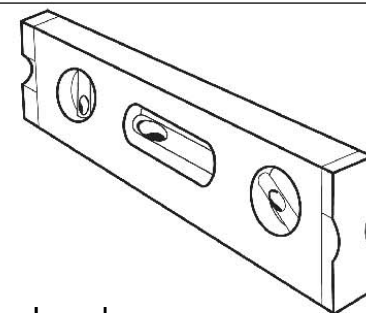

Level

PRODUCT SPECIFICATIONS

T46CLASPEDPOR-3 POTABLE TABLE WITH 3 SEATS

Seats: 11 gauge sheet steel is die formed with laser cut design . Seat support pieces are 11 gauge laser cut sheet steel. Top has 7 gauge x 1-1/2" flat bar center support and mounting bracket understructure. All electrically MIG welded.

Coating: Oven fused functionalized polyethylene copolymer-based thermoplastic. Fluidized bed coating application with superior mechanical performance, impact resistance and UV-stability.

Frame: Main support column is 4"x4"x11 gauge pre-galvanized structural steel tubing. Arms are fabricated from 2-7/8" O.D. x 12 gauge pre-galvanized structural steel tubing welded to 1/4" precision punched plates for attachment to the main column and 2"x2"x3/16" structural steel angle for lateral seat support. Seat attachment points are 10 gauge precision punched tabs. Table top attachment structure is fabricated from 2"x2"x3/16" structural steel angle and top attachment points are 7 gauge x 1-1/2" steel flat bar. Frame Coating: Electrostatic powder coated application oven cured.

Hardware: All stainless steel hardware fasteners.

Dimensions: Top is 46" square x 31-5/16" high. Seats are 14-5/16" wide x 36" long x 18-5/16" high. Outside to outside dimensions of 3 seat table is 80" x 64" x 31-5/16".

COMPONENTS

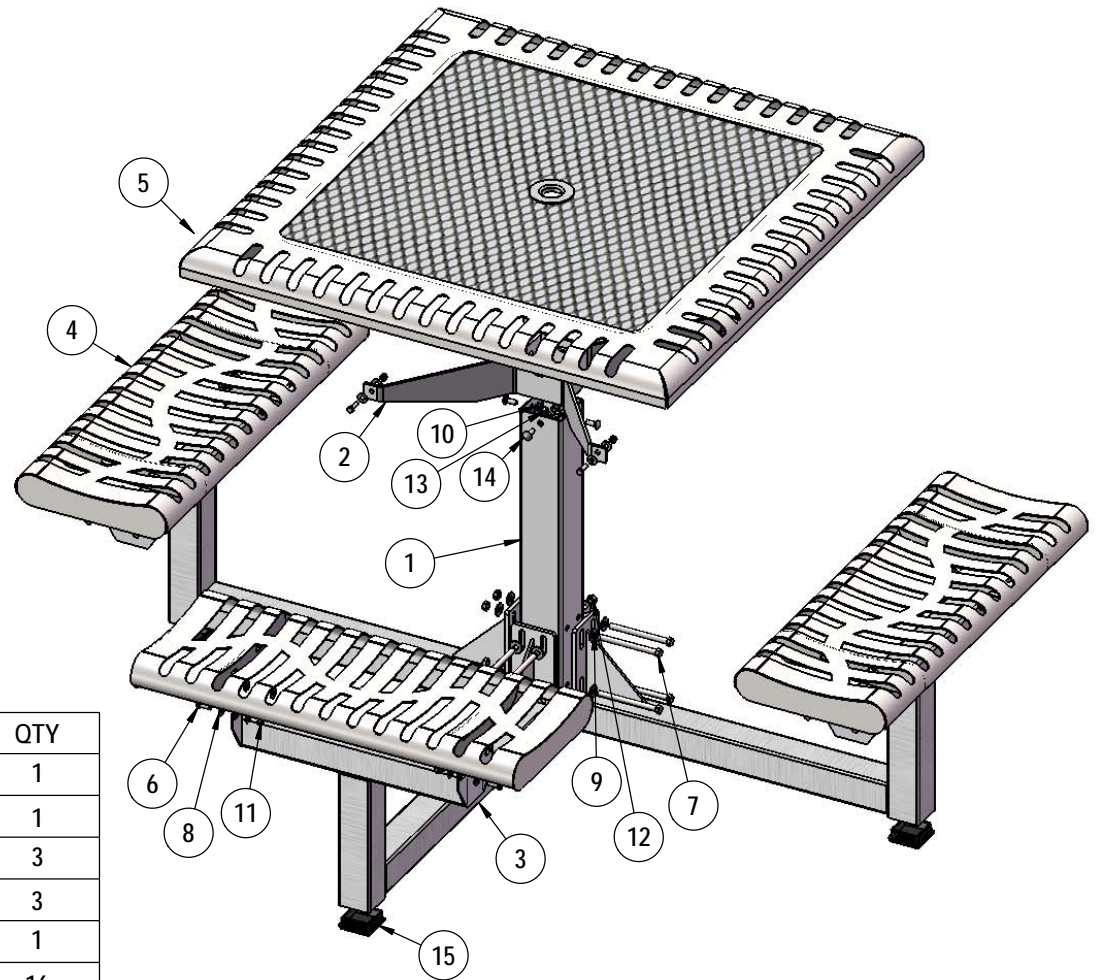

ITEM NO.	PartNo	DESCRIPTION	QTY
1	01-04-0683	338 PEDPOR post	1
2	P-01-04-0150	H Bracket	1
3	P-V338-ARM	338 vinyl arm	3
4	CLASS36-S	Classic 36" Seat	3
5	CLASS46-T	Classic Top 46" square	1
6	33-05-0029	5/16" x 1" Machine Bolt (SS)	16
7	33-06-0050	7/16" x 5-1/2" Machine Bolt	8
8	33-02-0007	5/16" SS Washer	32
9	33-02-0004	7/16" SS Washer	16
10	33-02-0008	3/8" Flat Washer (SS)	4
11	33-03-0012	5/16" Kep Nut (SS)	16
12	33-01-0006	7/16" Hex Nut (Zinc)	8
13	33-01-0018	3/8" Hex Nut (SS)	4
14	33-06-0042	3/8" x 1" Carriage Bolt (SS)	4
15	HWM0490	Cap Square Ribbed Tube Ins 3" Tube od(10-14ga)black	3

Superior[®]
 RECREATIONAL PRODUCTS
 A PLAYCORE Company

STEP 1

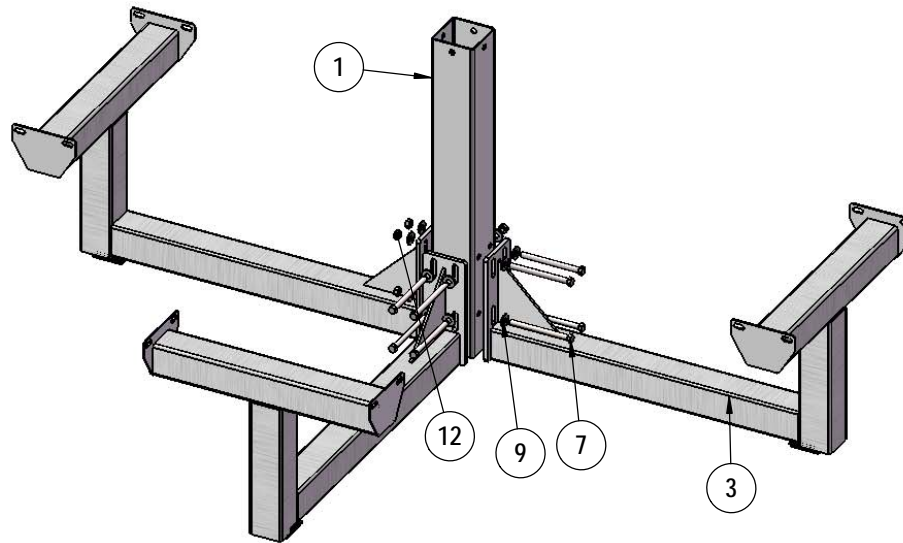

Attach the Arms to the Post using specified hardware.
Level Arms before moving on to the next step.

STEP 2

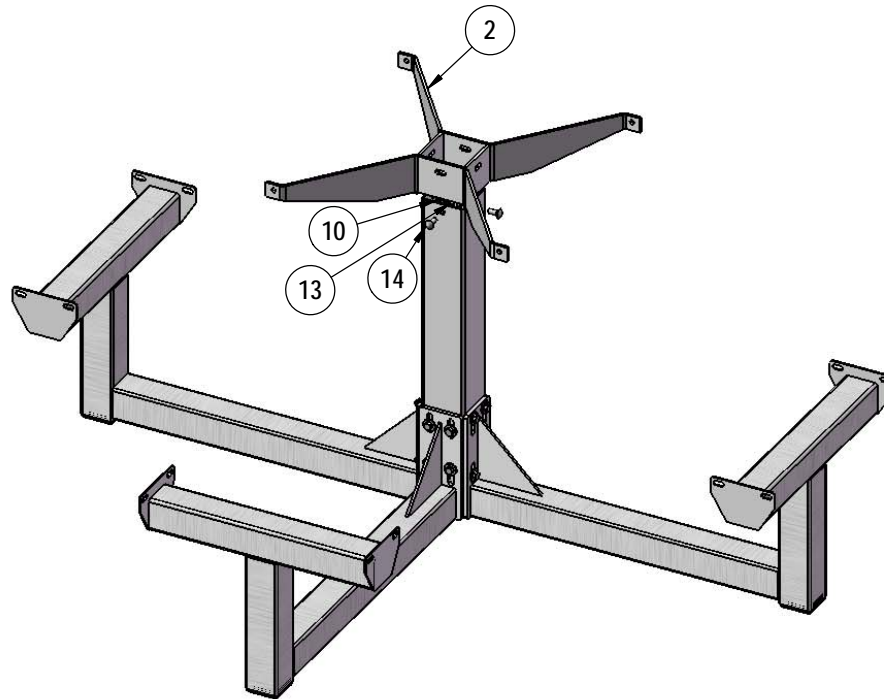

Attach the H-Bracket to the Post using specified hardware.

STEP 3

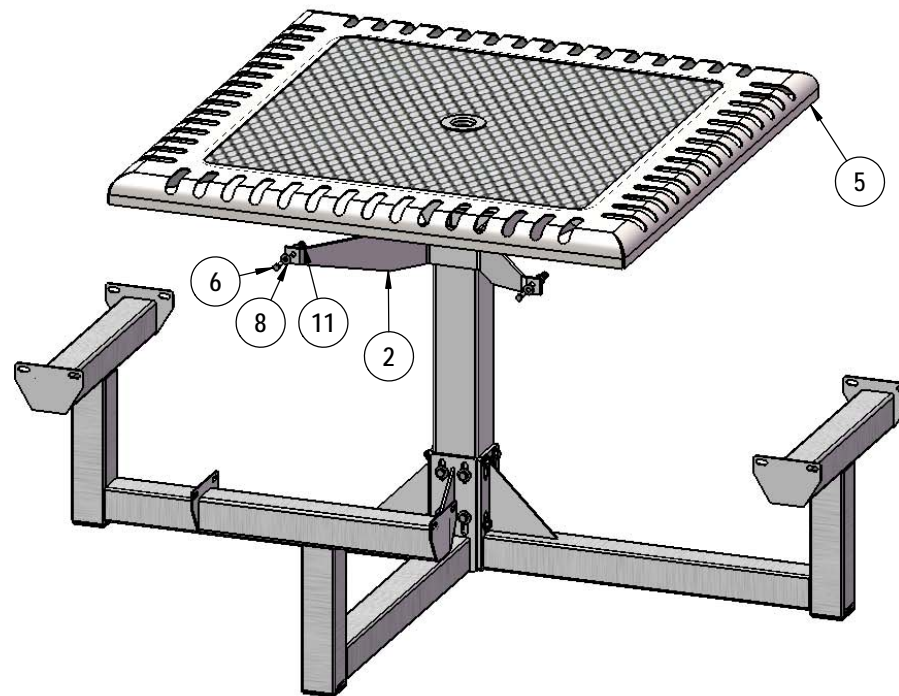

Attach the Top to the H-Bracket using specified hardware.

STEP 4

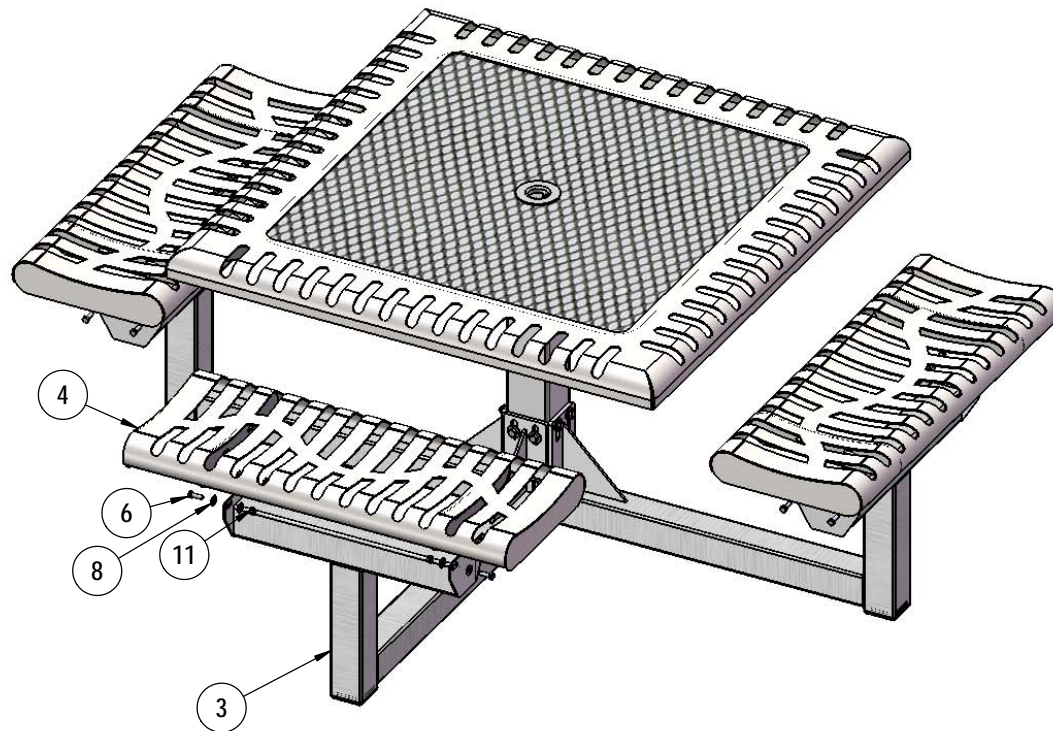

Attach the Seats to the Arms as shown using specified hardware.

OVERALL DIMENSIONS

