

Model # T46RCPED-3S

HARDWARE

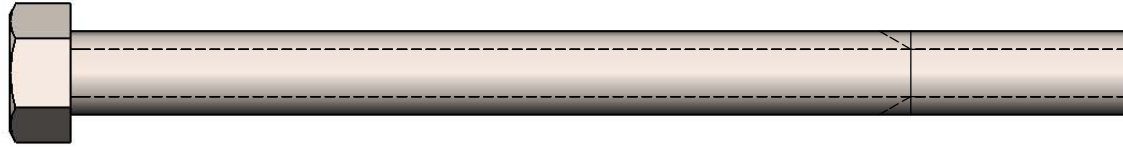

7/16" x 5-1/2"
Machine Bolt

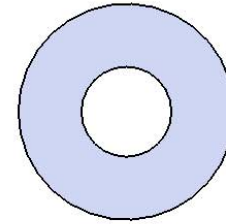

7/16" Washer

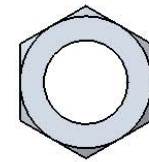

7/16" Hex Nut

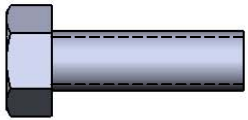

5/16" x 1"
Machine Bolt

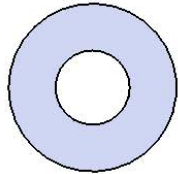

5/16" Washer

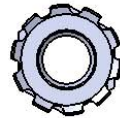

5/16" Kep Nut

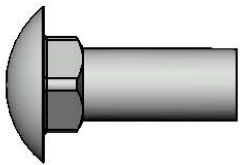

3/8" x 1"
Carriage Bolt

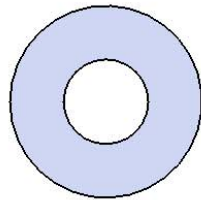

3/8" Washer

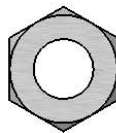

3/8" Hex Nut

TOOLS REQUIRED

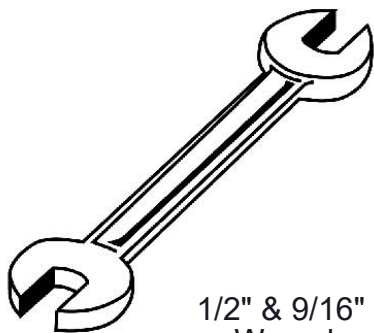

1/2" & 9/16"
Wrench



1/2" & 9/16"
Socket Wrench

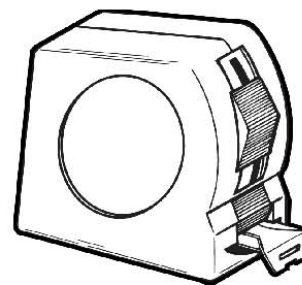

Tape Measure

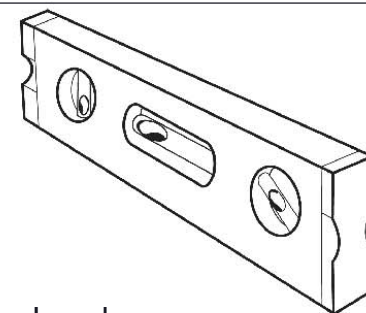

Level

PRODUCT SPECIFICATIONS

T46RCPED-3S **46" INGROUND TABLE WITH 3 SEATS**

Top & Seats: 2" x 2" x 1/8" angle frame. 3/4" #9 steel expanded metal. 7 gauge x 1-1/2" flat bar center support and mounting bracket understructure. Top is additionally supported to the corners with 7 gauge x 1-1/2" flat bar. Electrically MIG welded.

Coating: Oven fused functionalized polyethylene copolymer-based thermoplastic. Fluidized bed coating application with superior mechanical performance, impact resistance and UV-stability.

Frame: 2-3/8" O.D. x 13 gauge pre-galvanized structural steel tubing. Brace attachment points are 1-1/2"x2"x3/16" steel flat bar. Cross braces 1" O.D. x 16 gauge pre-galvanized structural steel tubing. Top is attached with 7 gauge 2"x2" die formed angle. Seat mounting points are 7 gauge x 1-1/2" die stamped steel flat bar. Legs are bent over a mandrel through the bend radius producing a wrinkle free bend. Holes are predrilled in legs for optional surface mounting. All electrically MIG welded.

Frame Coating: Electrostatic powder coated application oven cured.

Hardware: All stainless steel hardware fasteners.

Dimensions: Top is 46" x 46" x 30-1/8" high from ground. Overall height is 48-1/4". Seats are 10" wide x 36" long x 18" high from ground. Outside to outside dimensions of 3 seat table is 60-5/16" x 74-5/8".

COMPONENTS

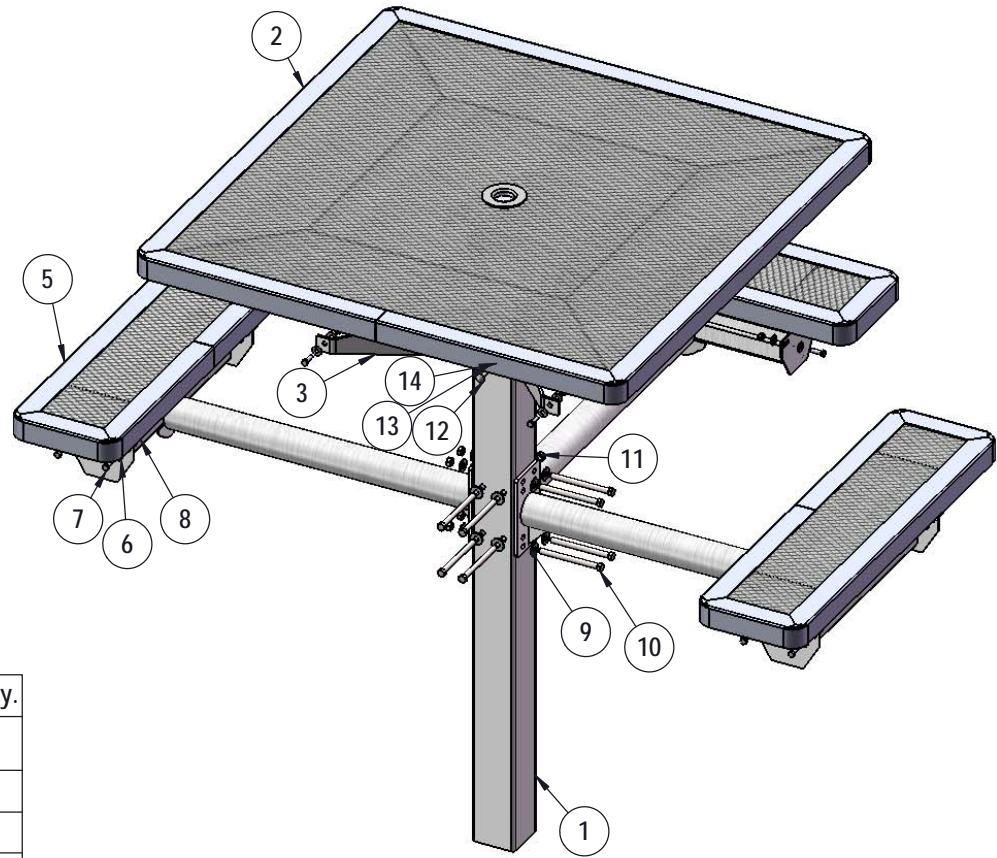

ITEM NO.	PartNo	DESCRIPTION	Qty.
1	P-338S or G-338S	338 IG post asem	1
2	RC46-T	46" square regal expanded top	1
3	P-01-04-0150	H Bracket	1
4	P-V338-ARM	338 vinyl arm	3
5	RC36-S	3' long x 10" wide regal expanded seat	3
6	33-02-0007	5/16" SS Washer	32
7	33-05-0029	5/16" x 1" Machine Bolt (SS)	16
8	33-03-0012	5/16" Kep Nut (SS)	16
9	33-02-0004	7/16" SS Washer	16
10	33-06-0050	7/16" x 5-1/2" Machine Bolt	8
11	33-01-0006	7/16" Hex Nut (SS)	8
12	33-06-0042	3/8" x 1" Carriage Bolt (SS)	4
13	33-02-0008	3/8" Flat Washer (SS)	4
14	33-01-0018	3/8" Hex Nut (SS)	4

STEP 1

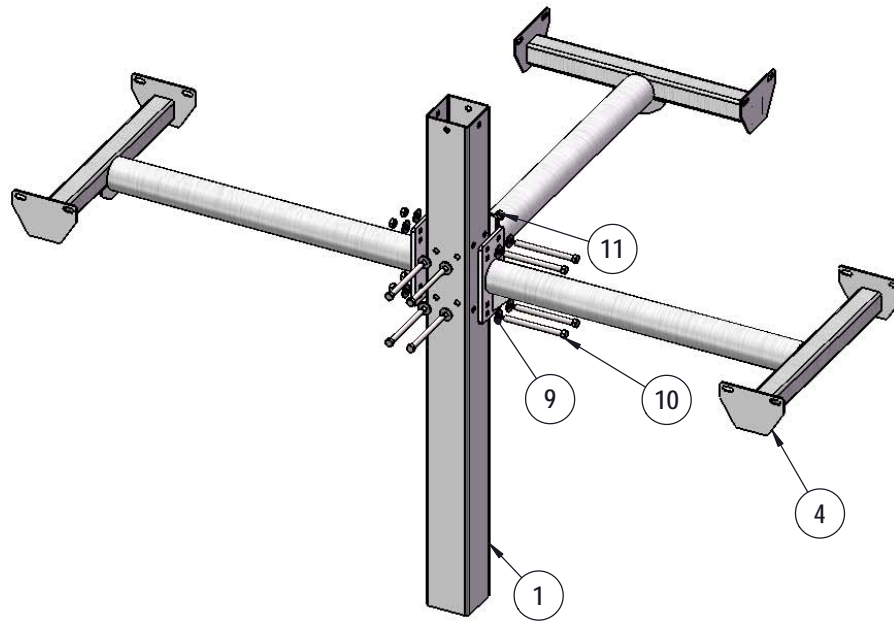

Attach the Arms to the Post using specified hardware.

STEP 2

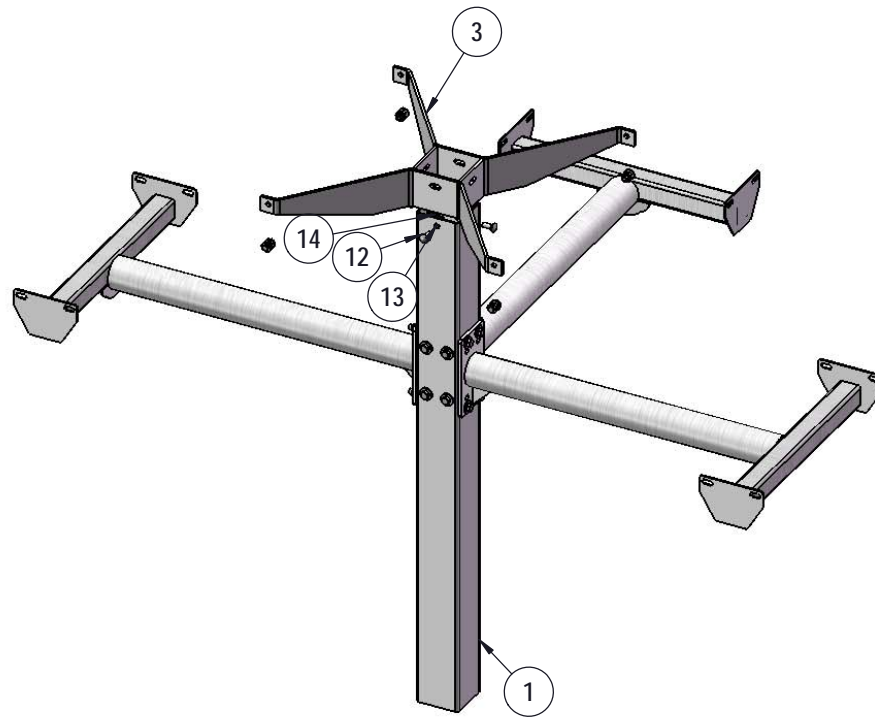

Attach the H-Bracket to the Post using specified hardware.

Superior[®]
RECREATIONAL PRODUCTS
A PLAYCORE Company

STEP 3

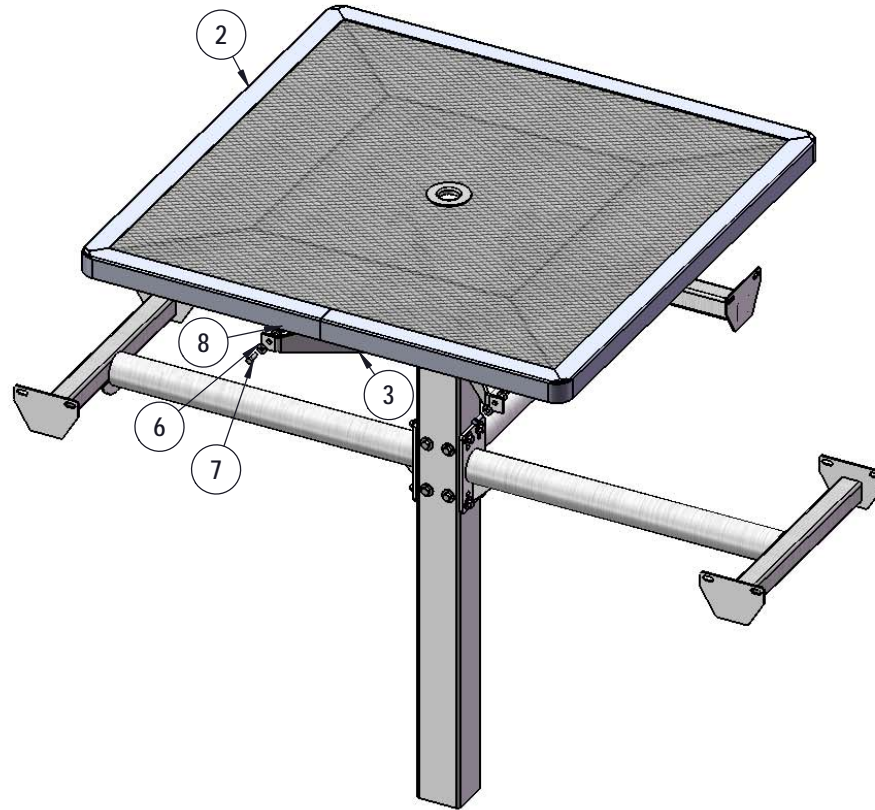

Attach the 46" Square Top to the H-Bracket using specified hardware.

STEP 4

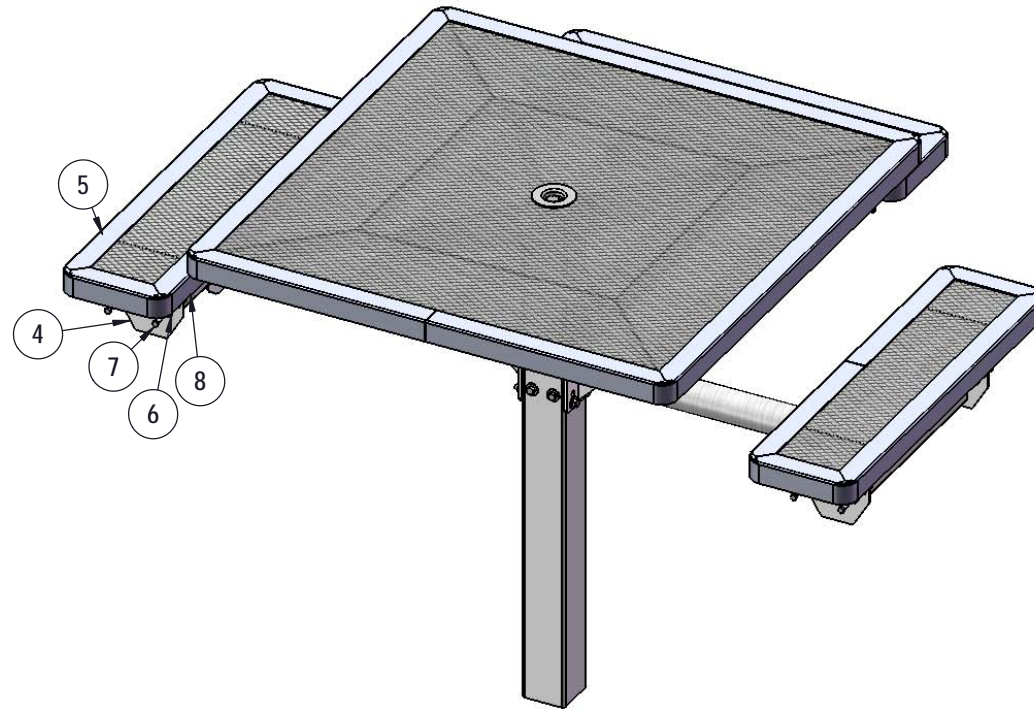

Attach the Seats to the Arms as shown using specified hardware.

Superior[®]
RECREATIONAL PRODUCTS
A PLAYCORE Company

FOOTINGS

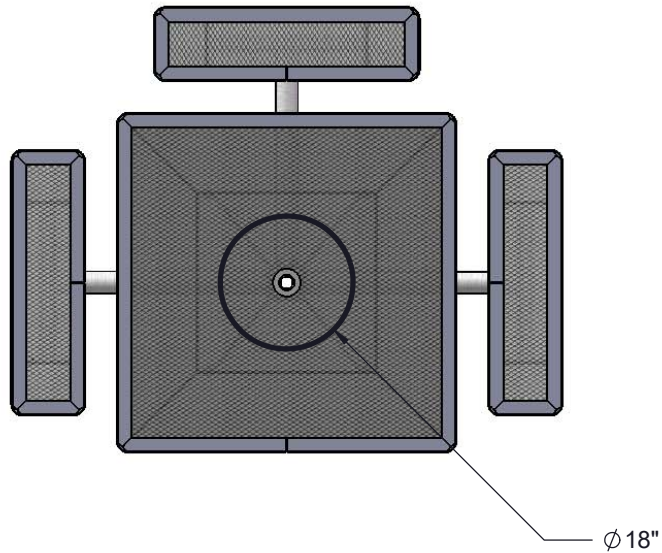

Estimated Required Concrete:
12 - 50lb Bags of Concrete Mix

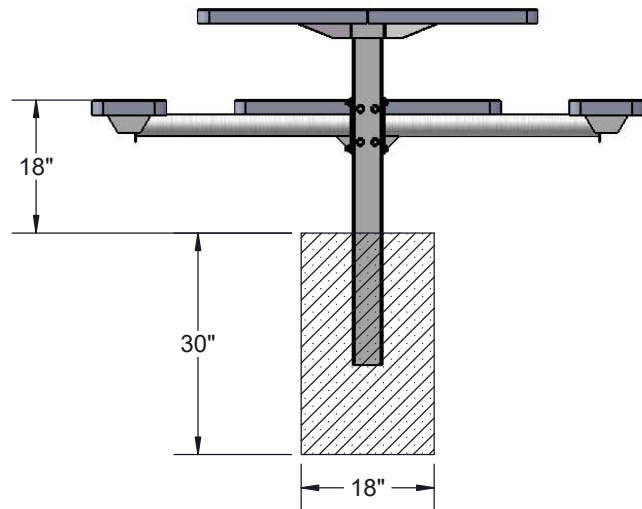

OVERALL DIMENSIONS

