

Site Amenities

BY SUPERIOR RECREATIONAL PRODUCTS



Model #
T46ULPERF-3
T46ULPERF-3ADA

 **SUPERIOR**[®]
RECREATIONAL PRODUCTS
A **PLAYCORE** Company

HARDWARE

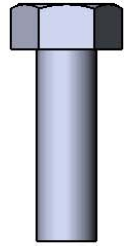

5/16" x 1"
Machine Bolt

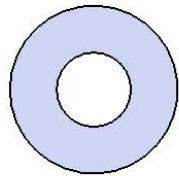

5/16" Washer

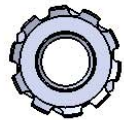

5/16" Kep Nut

PRODUCT SPECIFICATIONS

T46ULPERF-3 T46ULPERF-3ADA 46" ACCESSIBLE PORTABLE TABLE WITH 3 SEATS

Top & Seats: 11 gauge die formed angle frame 1"x1-7/8" with 3" radius corners. Seat and Top plates are fabricated from a 14 gauge plate precision punched with a 3/4" hole to create the punched hole pattern. The understructure/attachment plates are fabricated from 10 gauge x 1-1/2" flat bar. Top is additionally supported to the outer frame with 10 gauge x 1-1/2" flat bar. Electrically MIG welded.

Coating: Oven fused functionalized polyethylene copolymer-based thermoplastic. Fluidized bed coating application with superior mechanical performance, impact resistance and UV-stability.

Frame: 1-5/8" O.D. x 14 gauge pre-galvanized structural steel tubing. Brace attachment points are 1-1/2"x2"x3/16" steel flat bar. Cross braces 1" O.D. x 16 gauge pre-galvanized structural steel tubing. Top is attached with 7 gauge 2"x2" die formed angle. Seat mounting points are 7 gauge x 1-1/2" die stamped steel flat bar. Legs are bent over a mandrel through the bend radius producing a wrinkle free bend. All electrically MIG welded.

Frame Coating: Electrostatic powder coated application oven cured.

Hardware: All stainless steel hardware fasteners.

Dimensions: Top is 46" x 55" x 30" high. Seats are 10" wide x 36" long x 18-1/4" high. Outside to outside dimensions of 3 seat accessible table is 76-3/4" x 70".

COMPONENTS



ITEM NO.	PartNo	DESCRIPTION	QTY
1	T-EP46H-T	46" Square Economy Handicap Top (Punched)	1
2	P-01-04-0121	358 Extension Tab	4
3	P-V358-L	358 Vinyl Leg L	2
4	P-V358-R	358 Vinyl Leg R	2
5	T-EP36-S	3' x 10" perf seat	3
6	33-02-0007	5/16" SS Washer	64
7	33-05-0029	5/16" x 1" Machine Bolt (SS)	32
8	33-03-0012	5/16" Kep Nut (SS)	32
9	P-01-04-0122	358 Crossbrace w/ Umbrella Tube	1
10	P-01-04-0440	358 Vinyl Leg LH	1
11	P-01-04-0441	358 Vinyl Leg RH	1

STEP 1

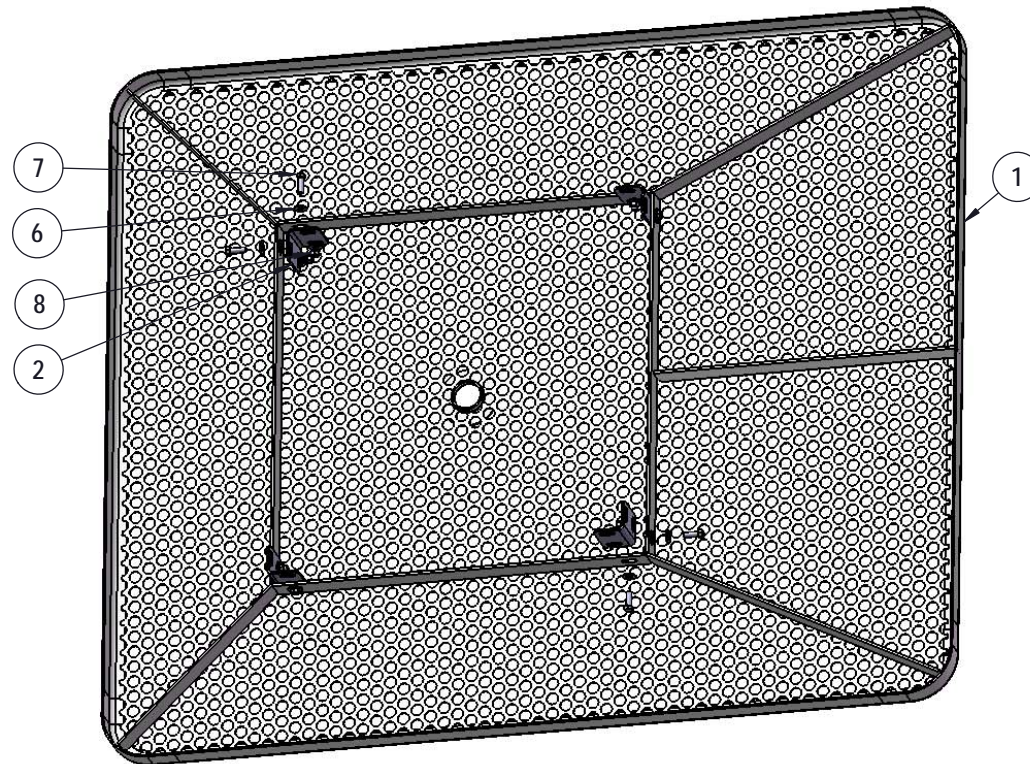

Attach the Extension Tabs to the 46" Square Handicap Top using specified hardware.

STEP 2

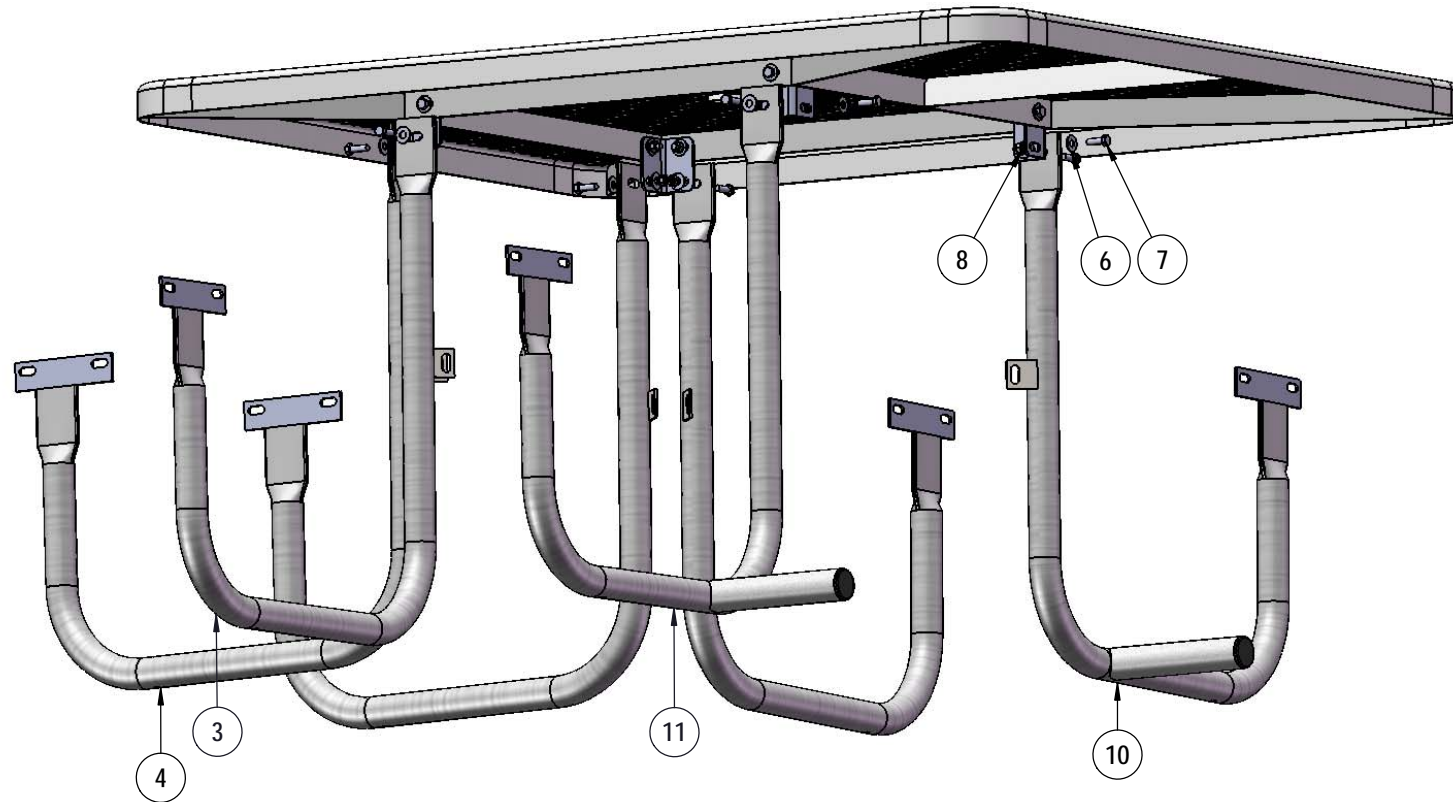

Attach the Legs to the outside of the Extension Tabs using specified hardware.

STEP 3

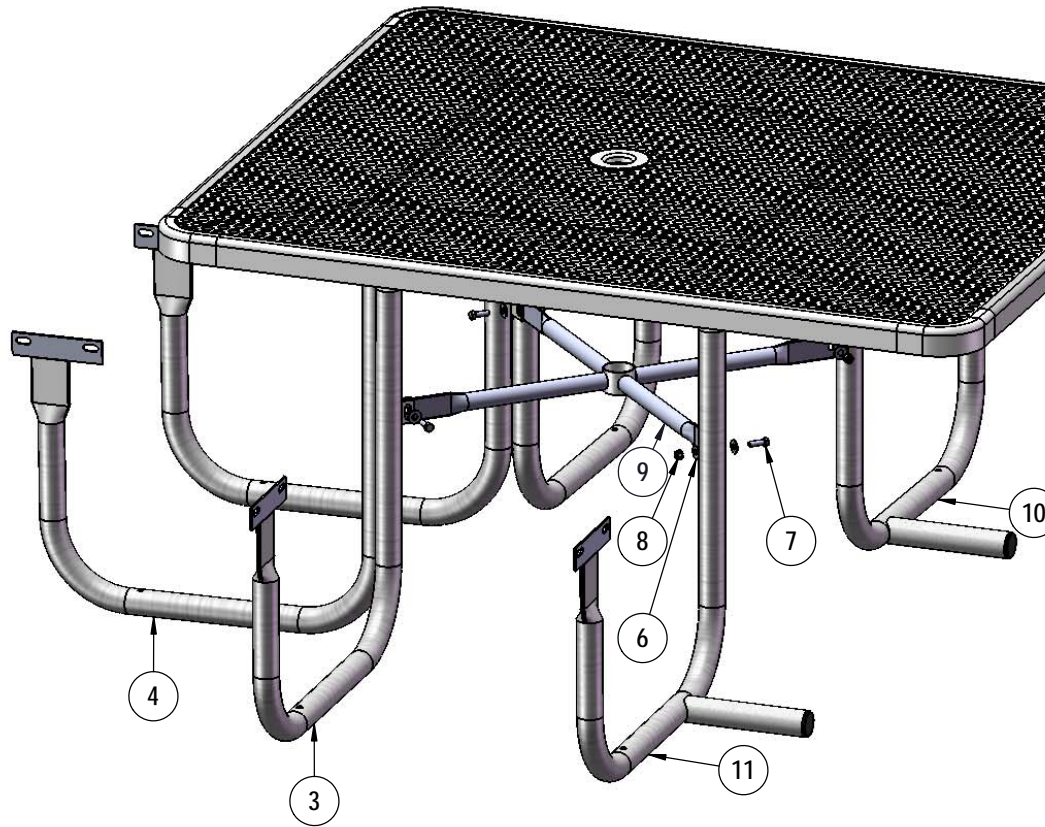

Attach the Crossbrace between the table legs as shown using specified hardware.

STEP 4

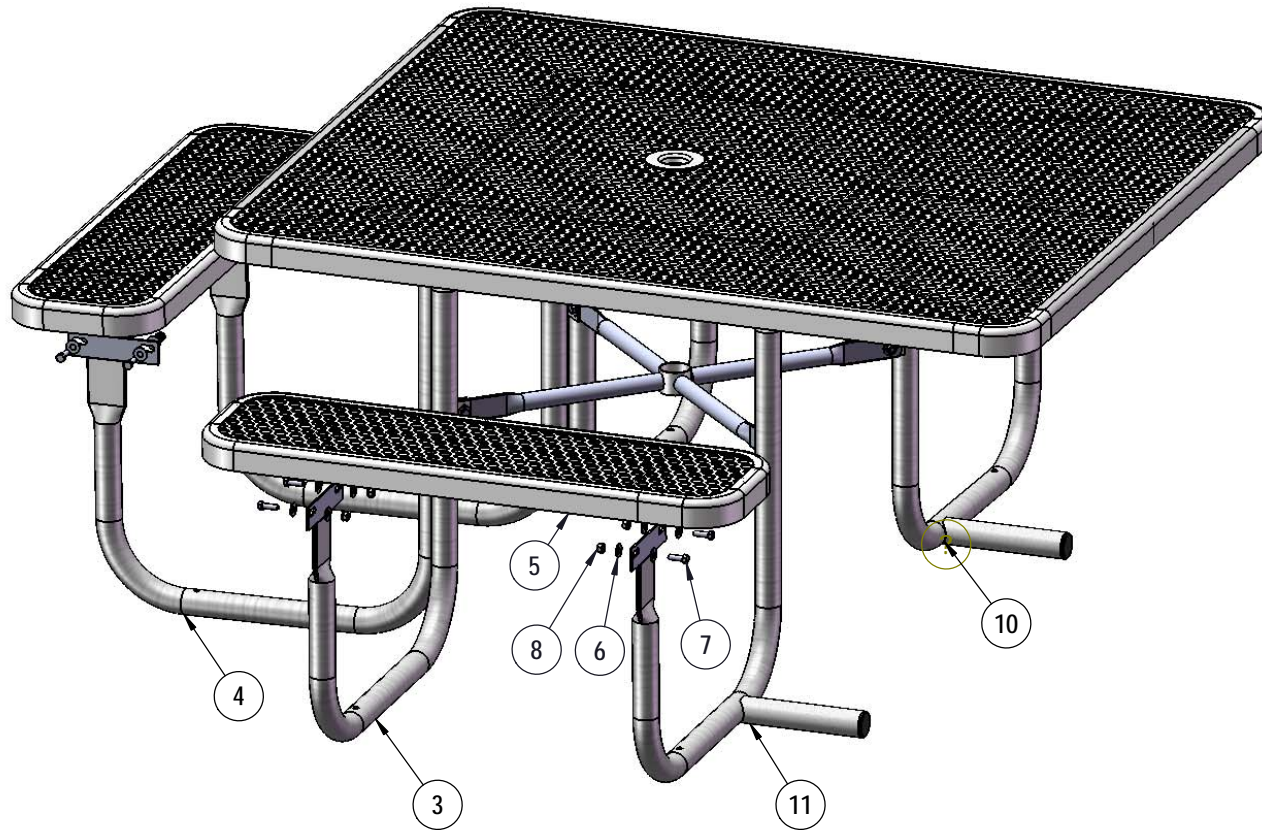

Attach the 3' Seats to the Legs using specified hardware.

OVERALL DIMENSIONS

