

Site Amenities

BY SUPERIOR RECREATIONAL PRODUCTS

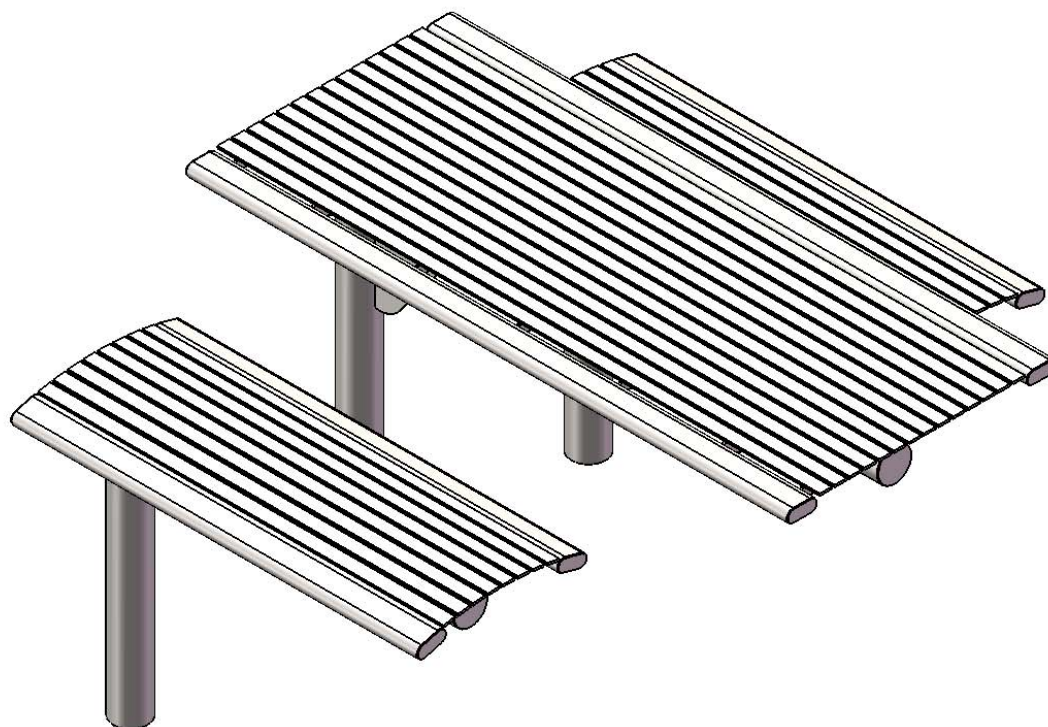

Model # T6ARS-ST-CANT

 **SUPERIOR**[®]
RECREATIONAL PRODUCTS
A **PLAYCORE** Company

HARDWARE



3/8" x 1"
Machine Bolt

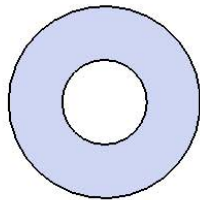

3/8" Flat Washer

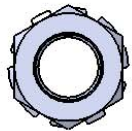

3/8" Kep Nut

ULTRA SITE PRODUCT SPECIFICATIONS

65S-HS6 CANTILEVER INGROUND MOUNT PICNIC TABLE

Seat: Is fabricated from 1 1/2" x 1/4" flat steel strips. Reinforced with 1/4" thick support ribs. End Planks are made from 1-1/2" x 3-1/2" steel oval tubing.

Frame: 4" diameter x 11 gauge structural steel tubing. Attachment plates are 1/4" thick flat steel. Gussets are 1/4" thick flat steel plate. Surface Mount (SM) plates are made from 1/2" thick flat steel. All electrically MIG welded.

Coating: Metal is sandblasted to near white condition. Coated with zinc rich epoxy primer and top coated with electrostatic powdercoat, oven cured.

Dimensions: 6' inground mounted table. Seats are 20" wide x 48" long. Top is 31-3/4" wide x 71" long. Seat height is 17-5/8" from the ground. Top height is 30-3/4" from the ground. The overall dimensions are 71" x 74" x 48-5/16"

COMPONENTS

Attach the 6' Top and 4' Seats to the Cantilever Legs using the specified hardware.

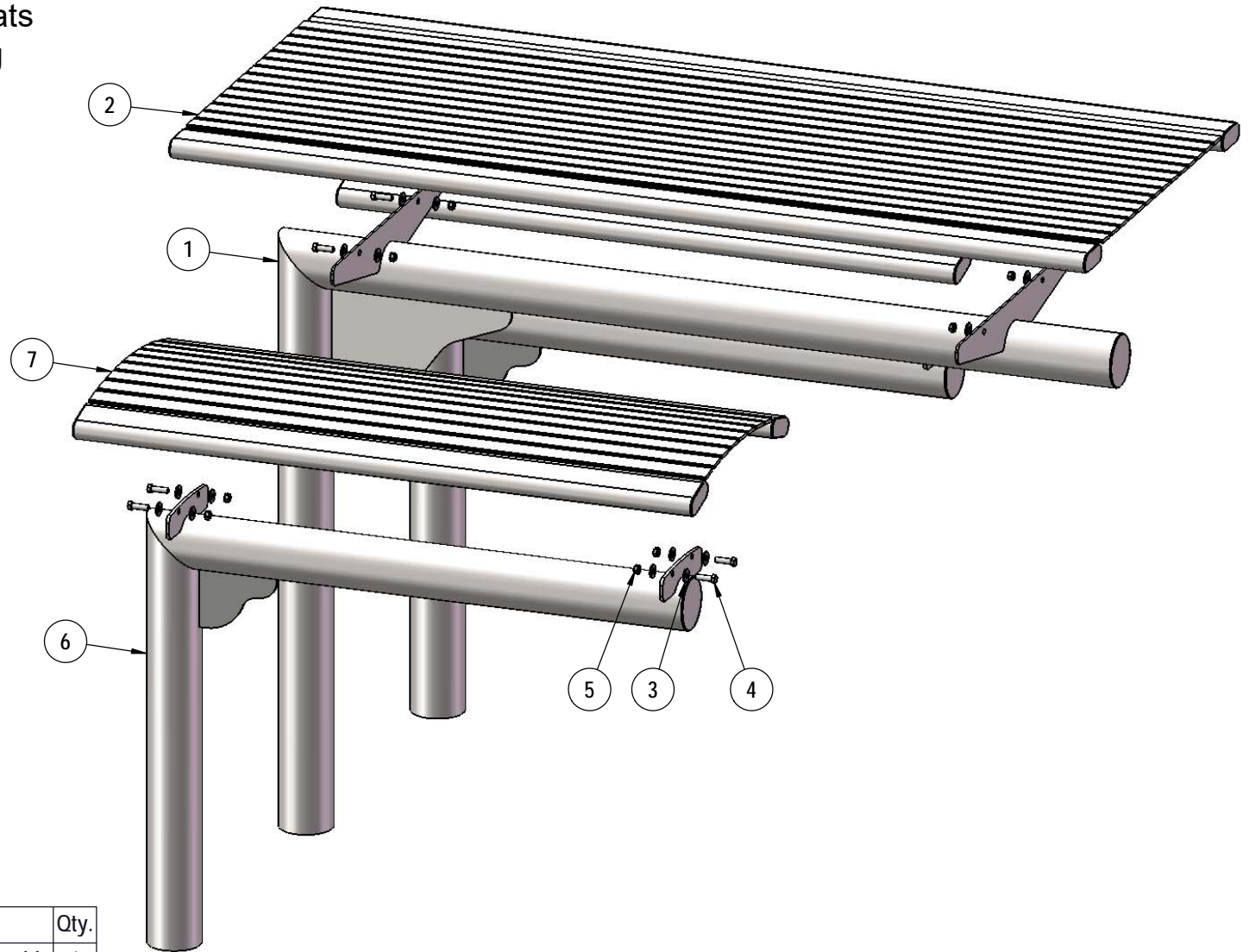

ITEM NO.	PartNo	DESCRIPTION	Qty.
1	01-01-0905	Cantilever Table IG Leg Assembly	1
2	01-04-0492	63 Table Top	1
3	33-02-0008	3/8" Flat Washer (SS)	24
4	33-05-0078	3/8" x 1 1/4" Machine Bolt (SS)	12
5	33-03-0013	3/8" Kep Nut (SS)	12
6	01-01-0889	66 Bench Leg - Inground	2
7	01-01-0897	4' horizontal slat seat assembly	2

FOOTINGS

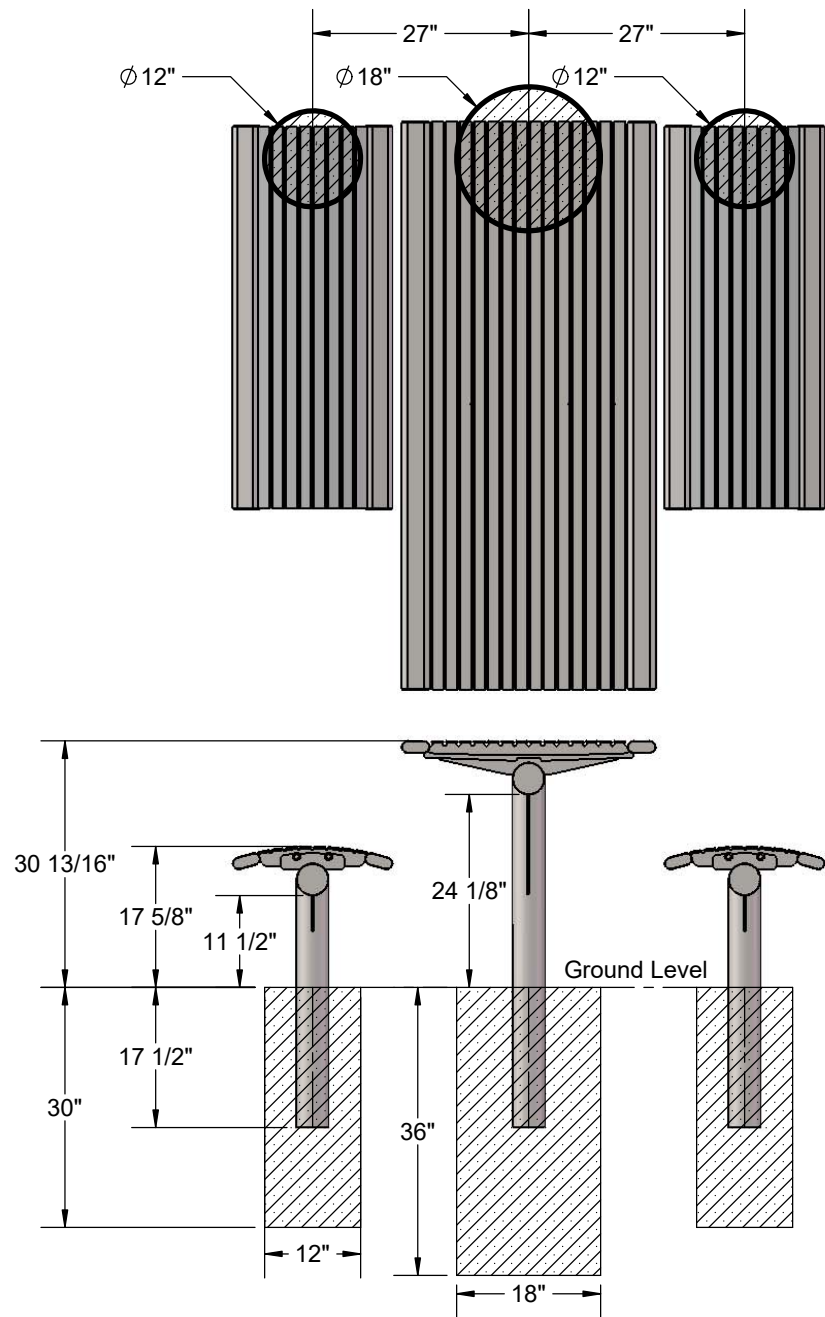

Estimated Concrete Required:
12 - 50lb Bags of Concrete Mix

OVERALL DIMENSIONS

