

Site Amenities

BY SUPERIOR RECREATIONAL PRODUCTS

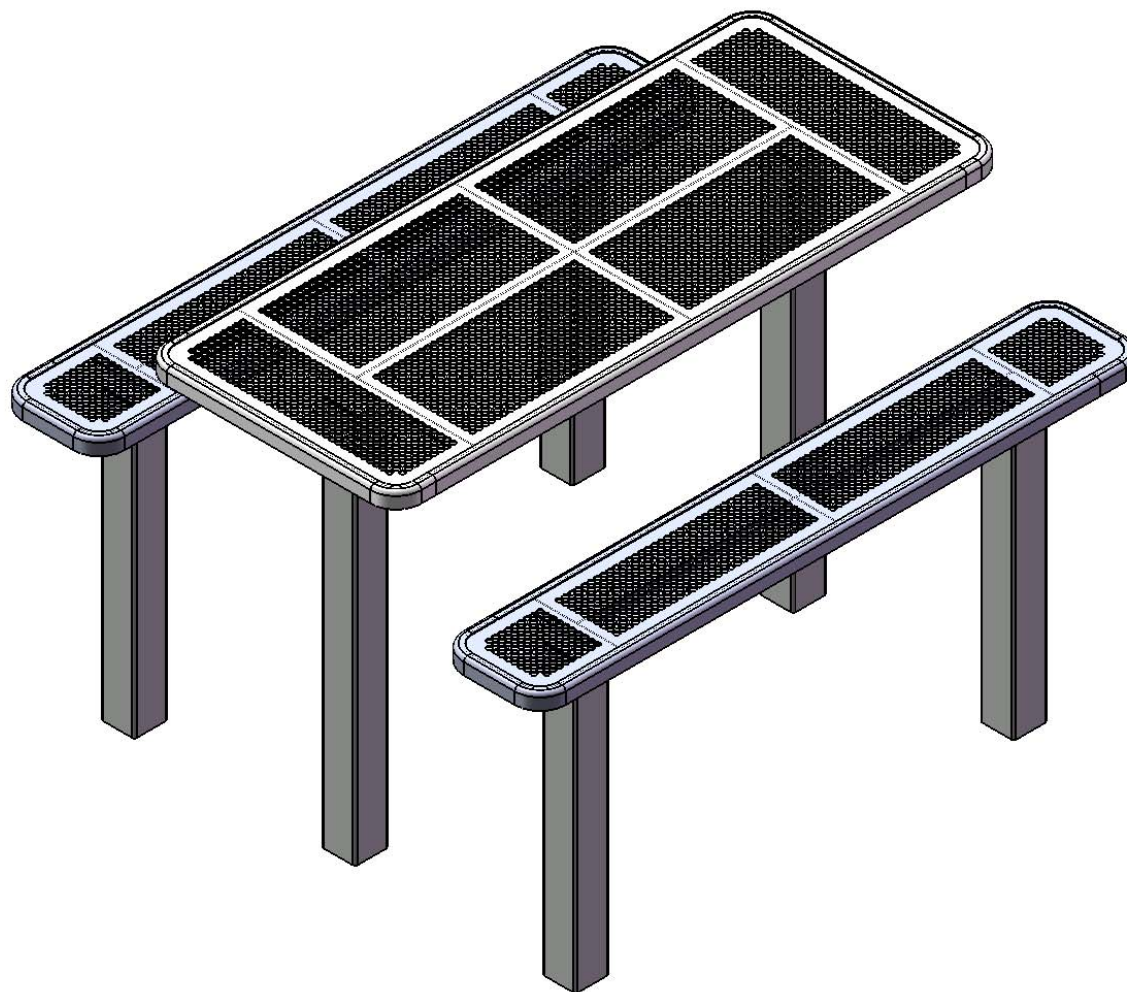

Model #
T6INNV4-4S

 **SUPERIOR**[®]
RECREATIONAL PRODUCTS
A **PLAYCORE** Company

HARDWARE

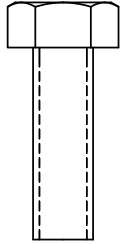

5/16" X 1"
Machine Bolt

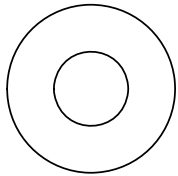

5/16" Washer

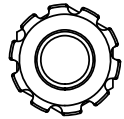

5/16" Kep Nut

PRODUCT SPECIFICATIONS

T6INNV4-4S 6' INGROUND PICNIC TABLE WALK-THROUGH DESIGN

Top & Seats: 11 gauge die formed angle frame 1"x1-7/8" with 3" radius corners. Seat and back plates are fabricated from a 12ga plate. Holes are precision punched at 1" diameter. 7 gauge x 1-1/2" flat bar center support and mounting bracket understructure. Electrically MIG welded.

Coating: Oven fused functionalized polyethylene copolymer-based thermoplastic. Fluidized bed coating application with superior mechanical performance, impact resistance and UV-stability.

Frame: 4 x 4 x 11 gauge structural steel square tubing. Legs are capped with a 4 x 4 x 3/16" steel flat bar. Seat and top mounting points 7 gauge x 1-1/2" die stamped steel flat bar. All electrically MIG welded.

Frame Coating: Electrostatic powder coated application oven cured.

Hardware: All stainless steel hardware fasteners.

Dimensions: 6' permanent picnic table walk-through design. Top is 30-1/8" wide x 72-1/8" long and is 30" high. Seats are 12-1/8" wide x 72-1/8" long and 18" high. Outside to outside dimension is 64" x 72-1/8".

COMPONENTS

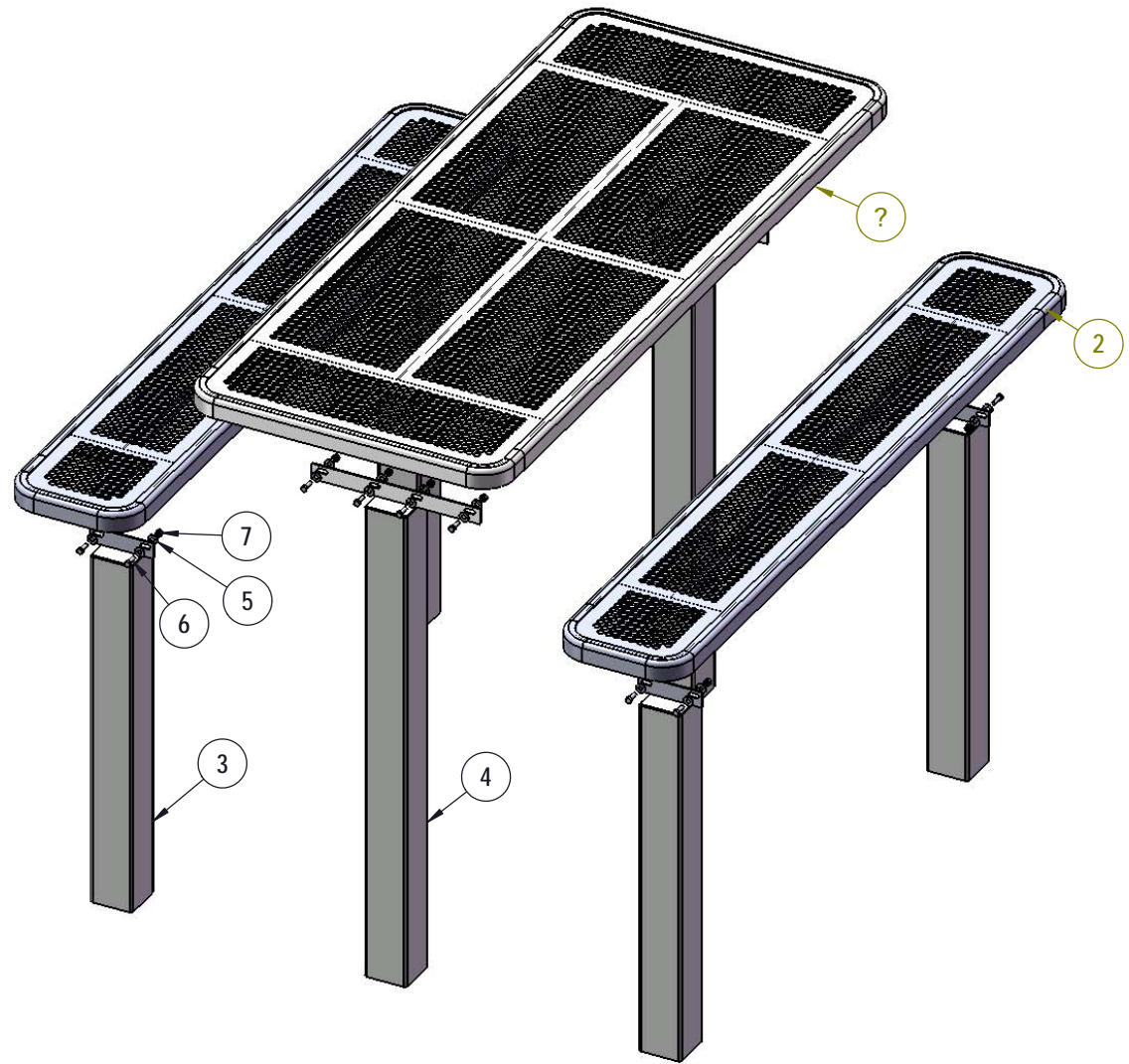

ITEM NO.	PartNo	DESCRIPTION	QTY
1	T-P72-T	6' Punched Top	1
2	T-P72-S	6' Punched Seat	2
3	P-V349S-S	Vinyl S Seat leg	4
4	P-V349S-T	Vinyl S top leg	2
5	33-02-0007	5/16" SS Washer	32
6	33-05-0029	5/16" x 1" Machine Bolt (SS)	16
7	33-03-0012	5/16" Kep Nut (SS)	16

STEP 1

Attach the 6' Top to the Top Legs using specified hardware.

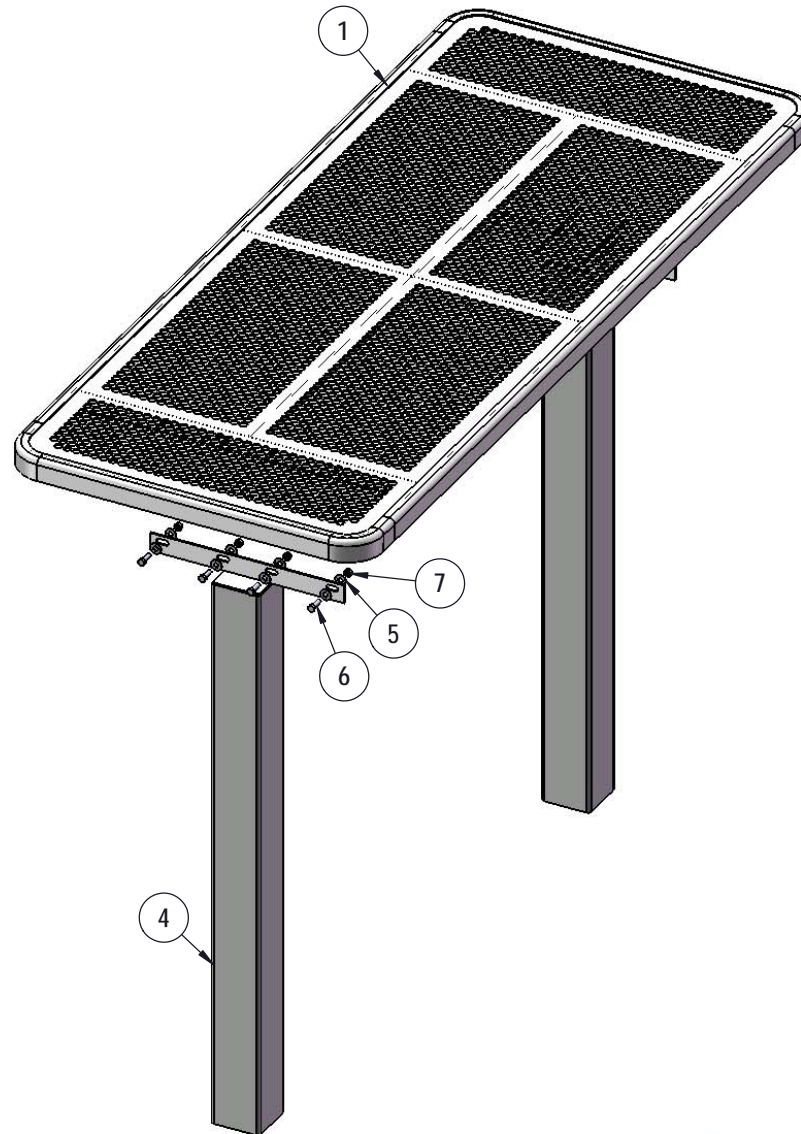

STEP 2

Attach the 6' Seats to the Seat Legs using specified hardware.

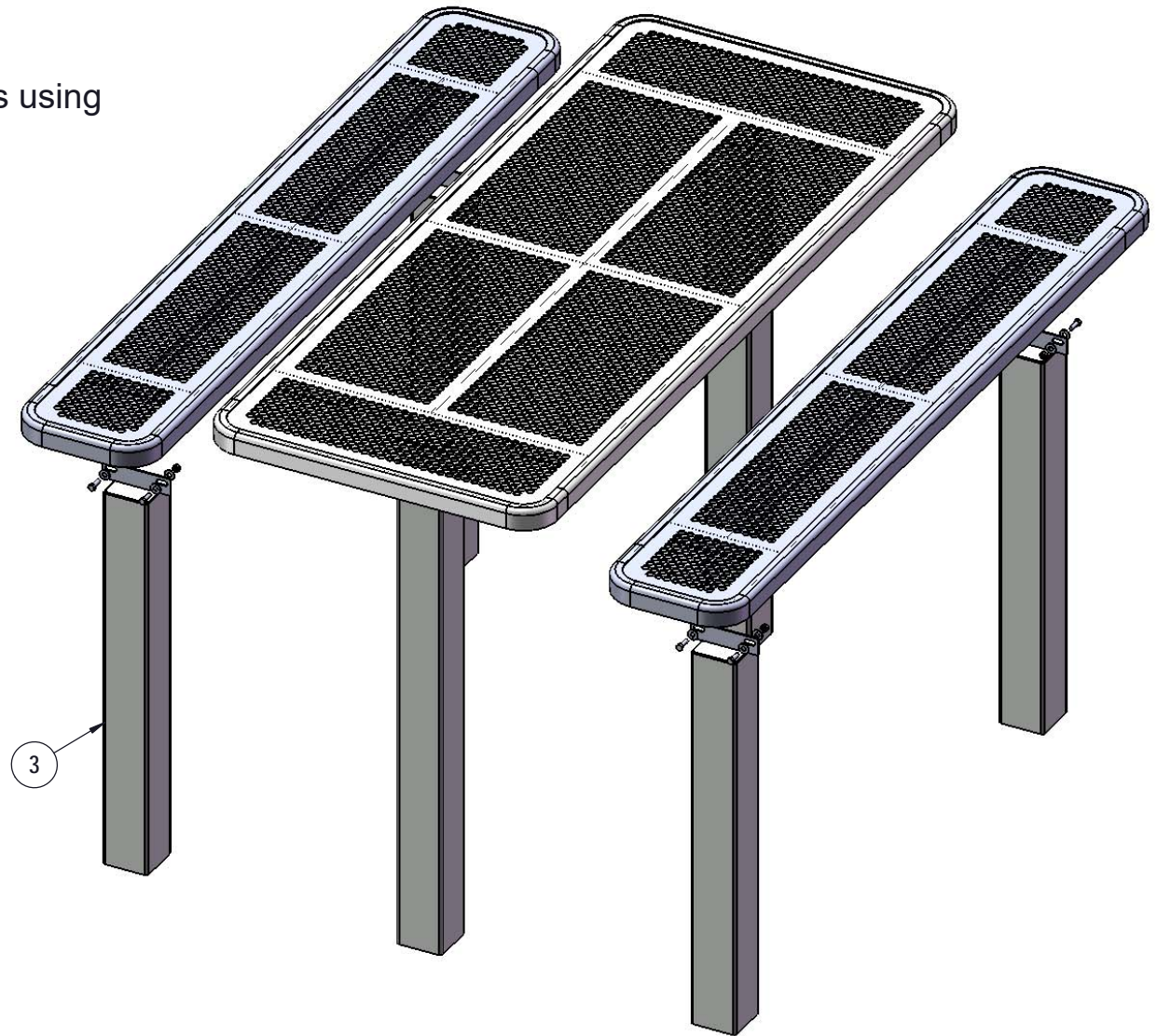

FOOTINGS

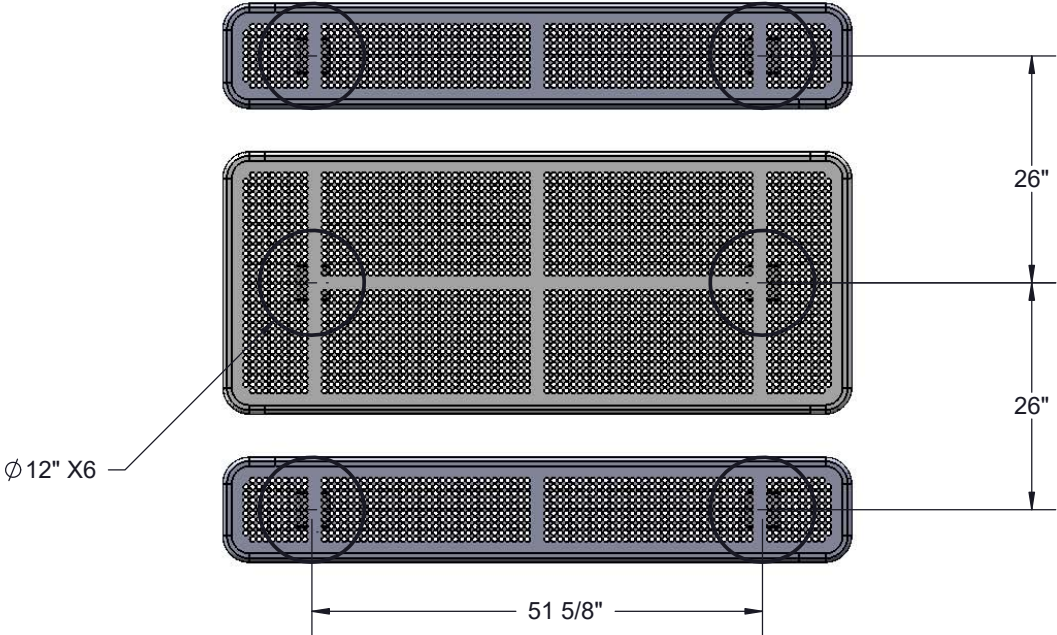

Estimated Required Concrete:
19 - 50 lb Bags of Concrete Mix

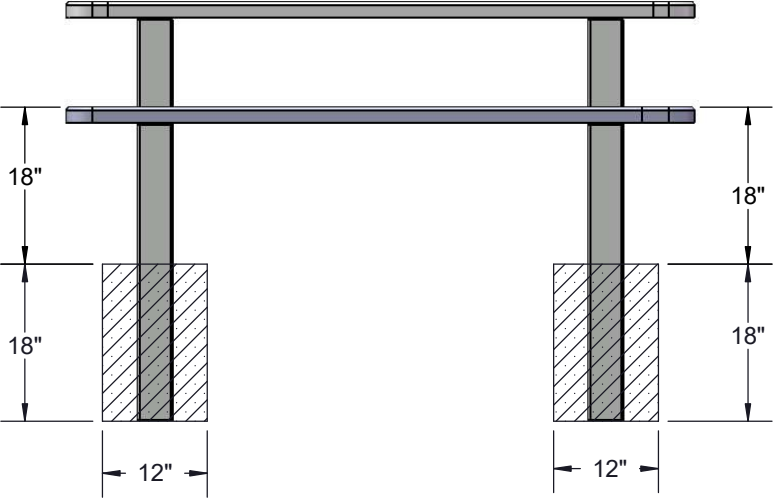

OVERALL DIMENSIONS

