

Site Amenities

BY SUPERIOR RECREATIONAL PRODUCTS

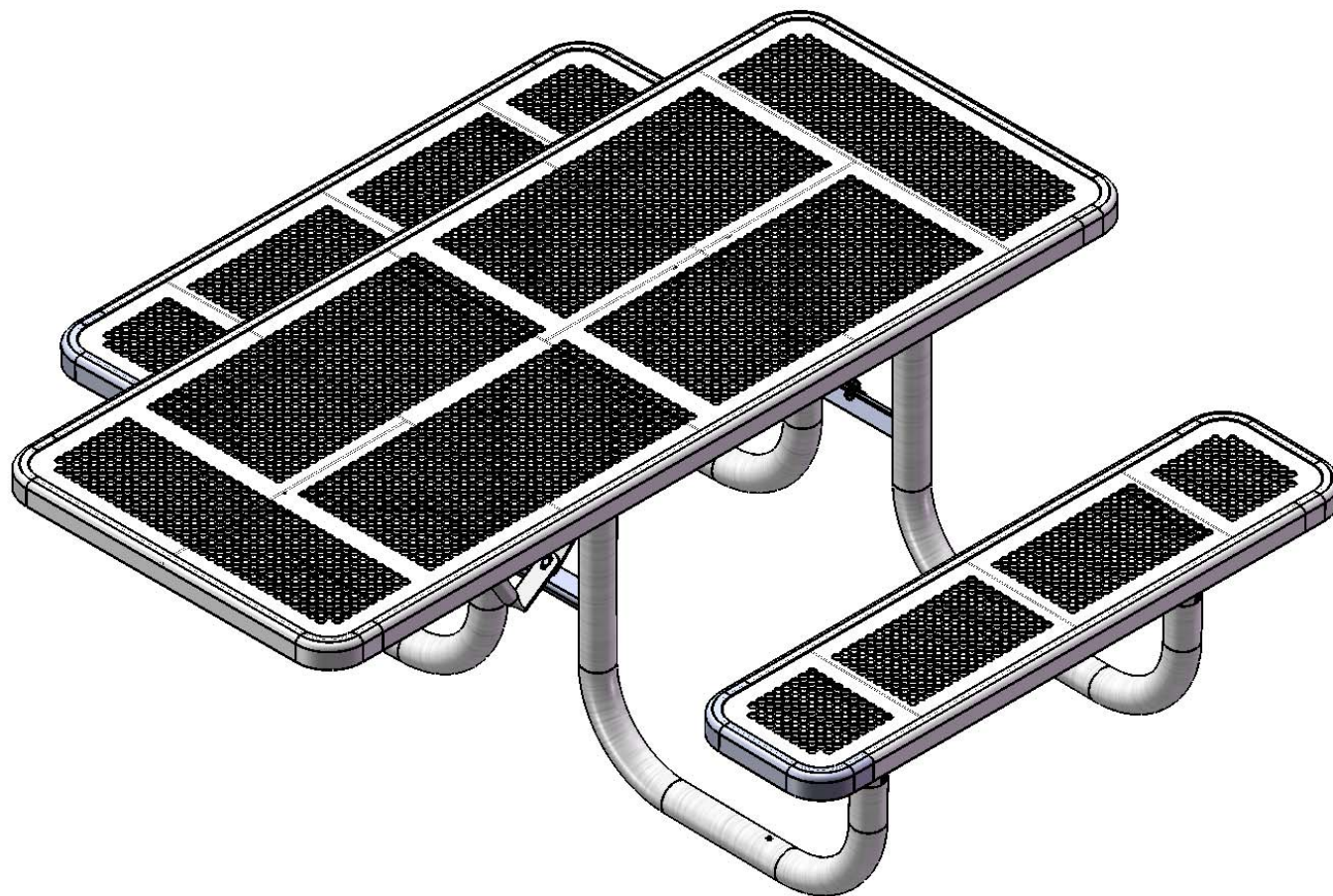

Model #
T6INNVHDCP

 **SUPERIOR**[®]
RECREATIONAL PRODUCTS
A **PLAYCORE** Company

HARDWARE

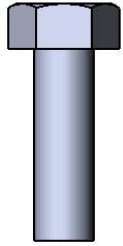

5/16" x 1"
Machine Bolt

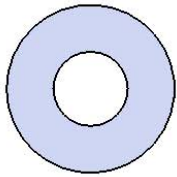

5/16" Washer

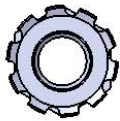

5/16" Kep Nut

PRODUCT SPECIFICATIONS

T6INNVHDCP 6' ACCESSIBLE PICNIC TABLE WALK-THROUGH DESIGN

Top & Seats: 11 gauge die formed angle frame 1"x1-7/8" with 3" radius corners. Seat and back plates are fabricated from a 12ga plate. Holes are precision punched at 5/8" diameter. 7 gauge x 1-1/2" flat bar center support and mounting bracket understructure. Electrically MIG welded.

Coating: Oven fused functionalized polyethylene copolymer-based thermoplastic. Fluidized bed coating application with superior mechanical performance, impact resistance and UV-stability.

Frame: 2-3/8" O.D. x 12 gauge pre-galvanized structural steel tubing. Cross braces 1" O.D. x 16 gauge pre-galvanized structural steel tubing. Brace attachment points 1-1/2"x1-1/2"x3/16" steel angle. Seat and top mounting points 7 gauge x 1-1/2" die stamped steel flat bar. Legs are bent over a mandrel through the bend radius producing a wrinkle free bend. All electrically MIG welded.

Frame Coating: Electrostatic powder coated application oven cured.

Hardware: All stainless steel hardware fasteners.

Dimensions: 6' accessible picnic table walk-through design. Top is 30" wide x 72" long and is 30-1/4" high. Seats are 12" wide x 48" long and 18-1/2" high. Outside to outside dimension is 68-1/2" x 72". The table over hangs the frame 33" on one end.

NOTE: 238 Single Sided Accessible Tables must be installed with Surface Mount Clamps or In-Ground Mount Posts to insure stability.

COMPONENTS

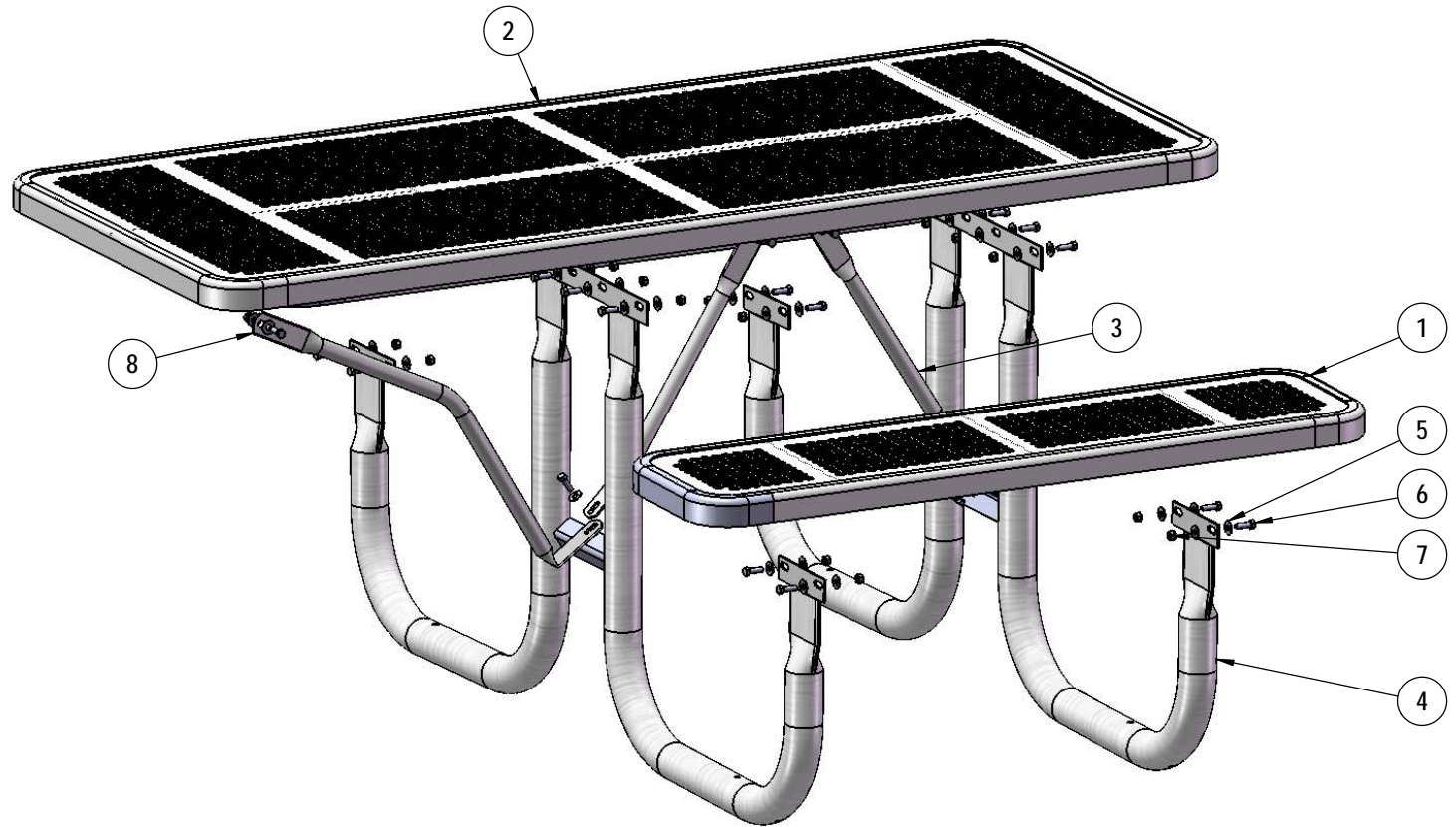

ITEM NO.	PartNo	DESCRIPTION	QTY
1	T-P48-S	4' Punched Seat	2
2	T-P72HS-T	6' HS Punched Top	1
3	P-01-04-0243	21 3/8" Brace	2
4	P-V238	238 Vinyl Frame	2
5	33-02-0007	5/16" SS Washer	42
6	33-05-0029	5/16" x 1" Machine Bolt (SS)	21
7	33-03-0012	5/16" Kep Nut (SS)	21
8	P-01-04-0148	158/238 HS Brace	1

STEP 1

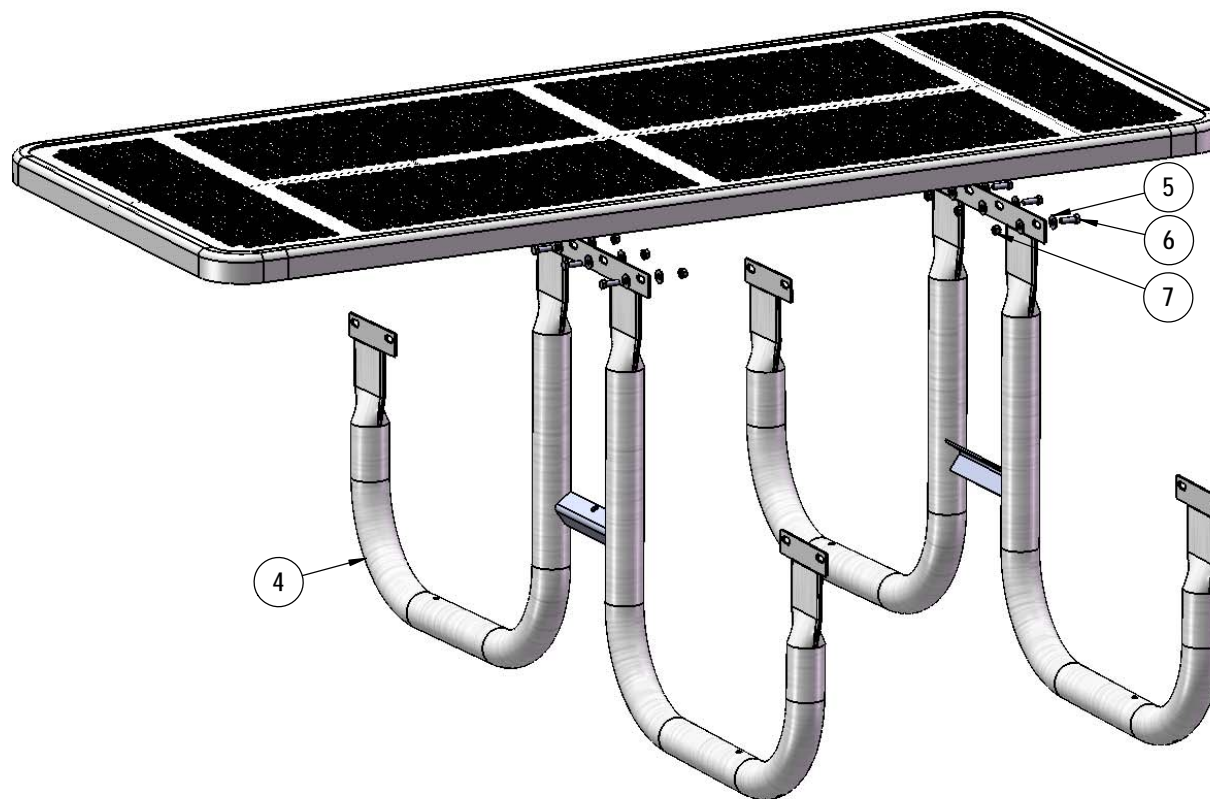

Attach the 6' HS Punched Top to the Legs using specified hardware.

NOTE: Single Sided Accessible Tables must be installed with Surface Mount Clamps or In-Ground Mount Posts to insure stability.

STEP 2

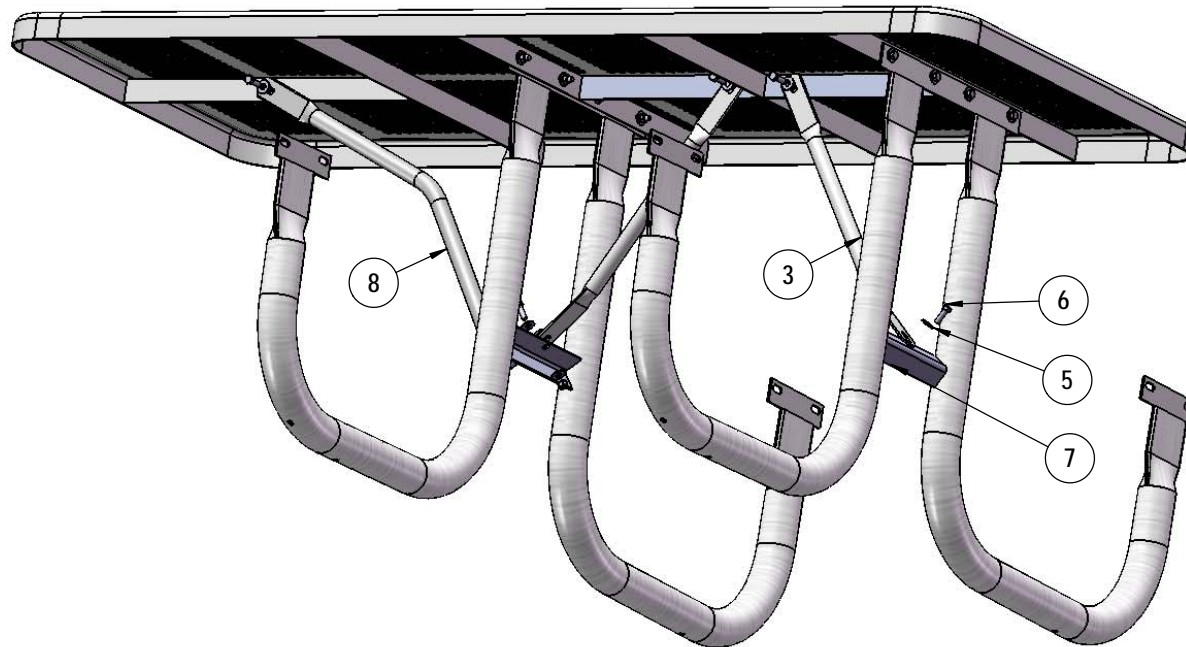

Attach the 21-3/8" and HS Braces to the 6' HS Punched Top and the Legs as shown using specified hardware.

STEP 3

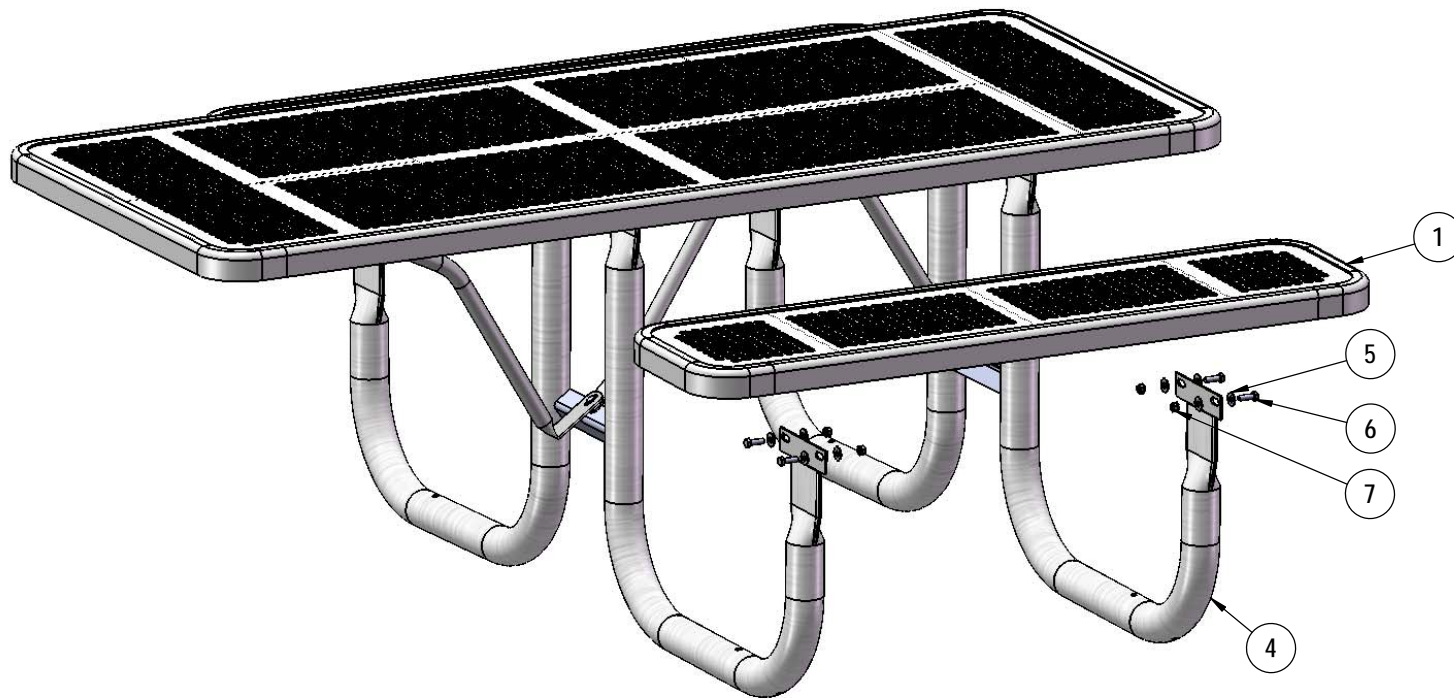

Attach the 4' Punched Seats to the Legs using specified hardware.

OVERALL DIMENSIONS

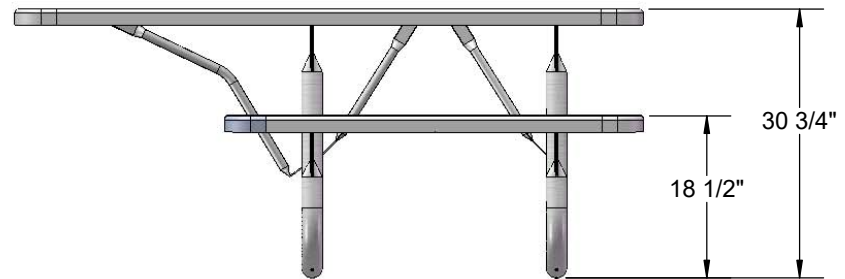
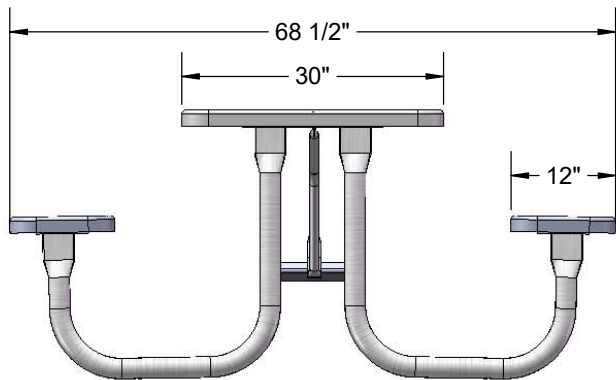
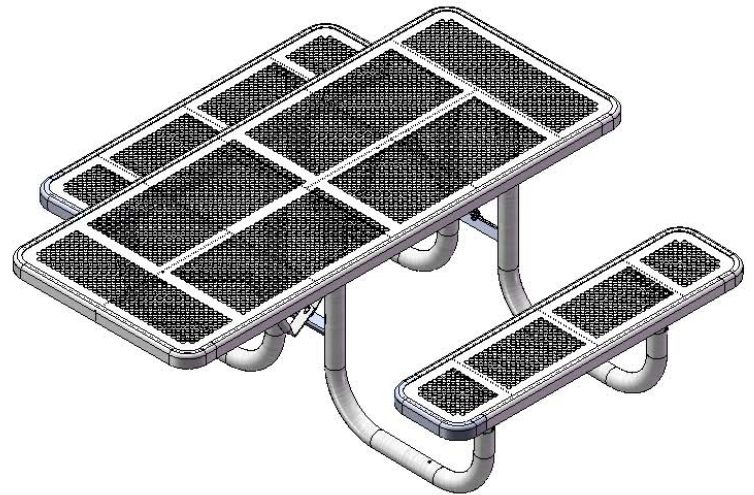
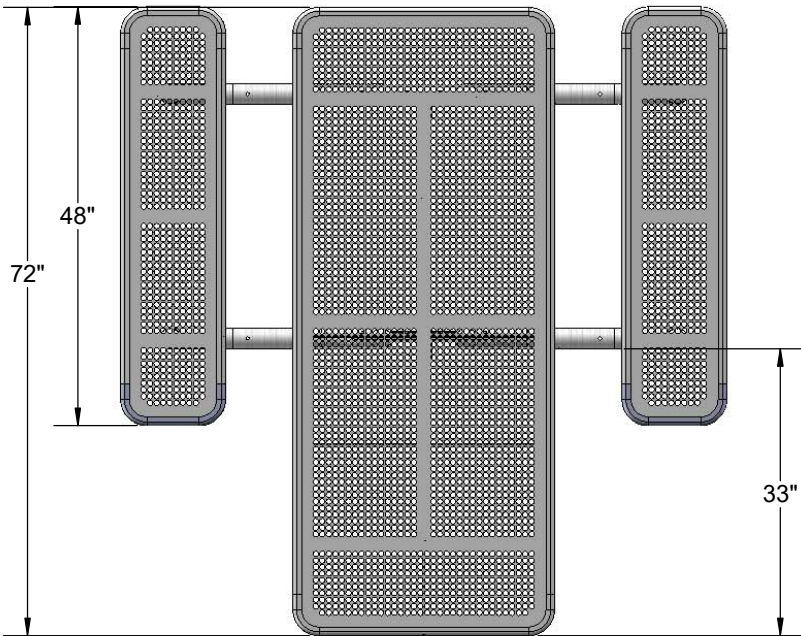

NOTE: 238 Single Sided Accessible Tables must be installed with Surface Mount Clamps or In-Ground Mount Posts to insure stability.