

Model # T6RCPEDHDCPSM

HARDWARE

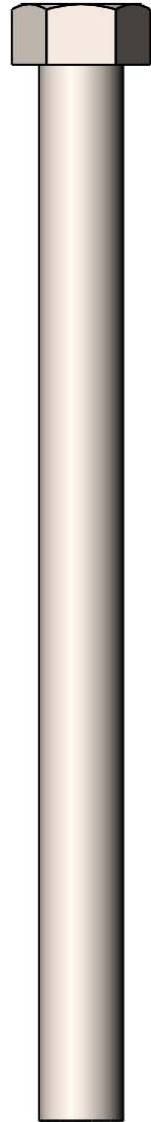

5/16" x 1"
Machine Bolt



7/16" x 5-1/2"
Machine Bolt

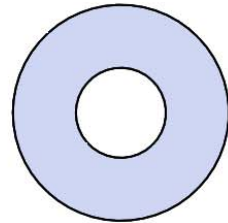

7/16" Washer



3/8" x 4"
Carriage Bolt

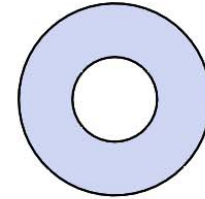

3/8" Washer

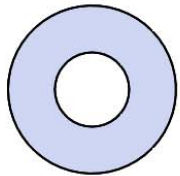

5/16" Washer

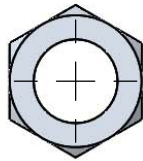

7/16" Hex Nut

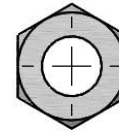

3/8" Hex Nut



5/16" Washer

PRODUCT SPECIFICATIONS

T6RCPEDHDCPSM RECTANGULAR SURFACE MOUNT TABLE

Seat & Back: 2" x 2" x 1/8" formed angle frame with 1-1/2" radius corners. 3/4" #9 steel expanded metal. 7 gauge x 1-1/2" flat bar center support and mounting bracket understructure. Electrically MIG welded.

Coating: Oven fused functionalized polyethylene copolymer-based thermoplastic. Fluidized bed coating application with superior mechanical performance, impact resistance and UV-stability.

Frame: Main support column is 4"x 4"x 11 gauge pre-galvanized structural steel tubing with a 16" x 16" x 1/2" surface mount plate. Arms are fabricated from 3"x 3"x 11 gauge pre-galvanized structural steel tubing welded to 1/4" precision punched plates for attachment to the main column and 2"x 2"x 3/16" structural steel angle for lateral seat support. Seat attachment points are 10 gauge precision punched tabs. Table top attachment structure is fabricated from 2"x 2"x 3/16" structural steel angle and top attachment points are 7 gauge x 1-1/2" steel flat bar. All electrically MIG welded.

Frame Coating: Electrostatic powder coated application oven cured.

Hardware: All stainless steel hardware fasteners.

Dimensions: Top is 30" wide x 72" long x 30-3/8" high. Seats are 10" wide x 48" long x 19-3/16" high. Outside to outside dimensions are 65-3/4" x 72".

COMPONENTS

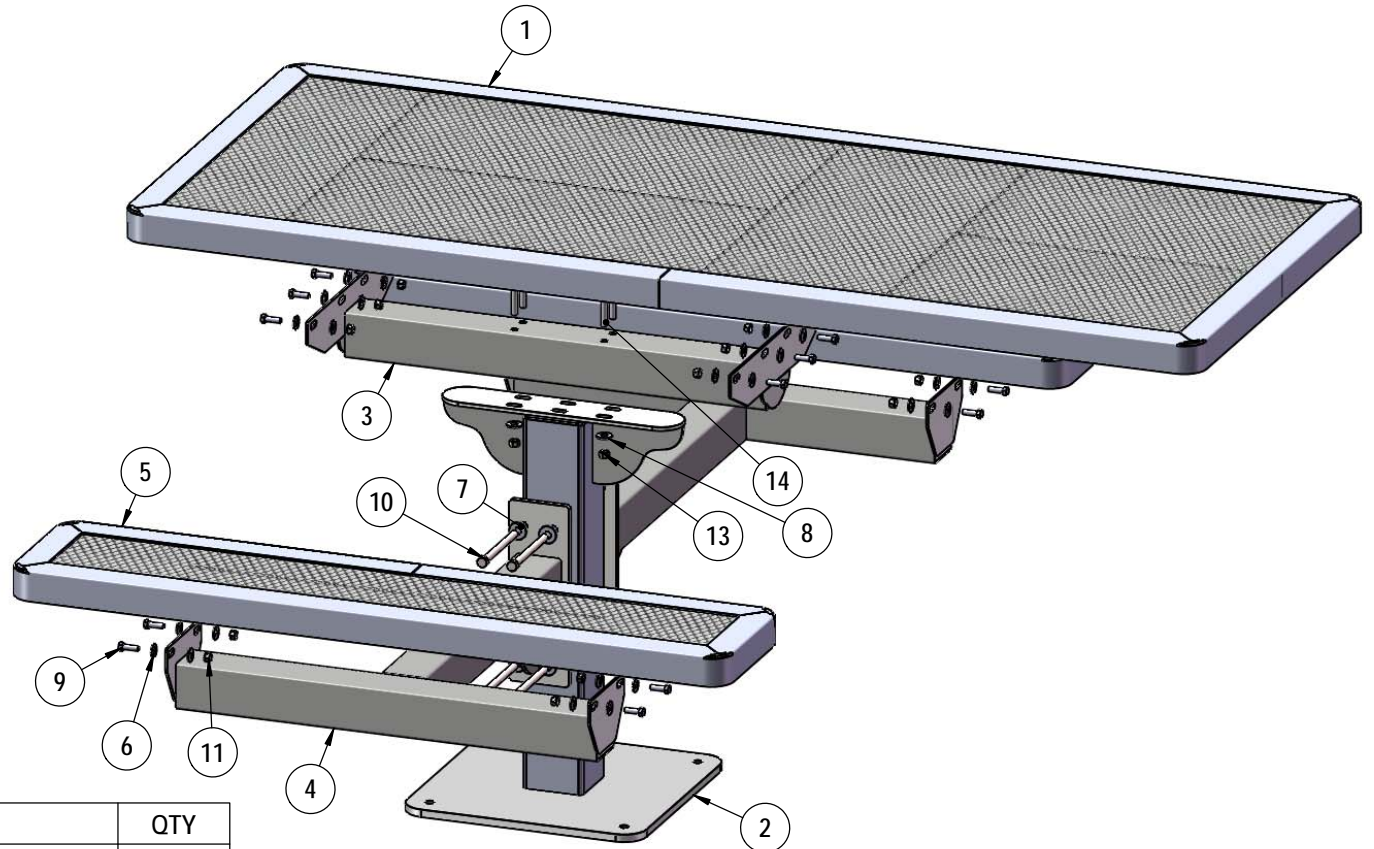

ITEM NO.	PartNo	DESCRIPTION	QTY
1	RC72HS-T	6' HS regal expanded top	1
2	337SM	SM Post Assembly	1
3	P-V337-48-T	4' 337 Top Vinyl Bracket Assembly	1
4	V337-48-S	337 4' Vinyl Seat Arm Assem	2
5	RC48-S	4' long x 10" wide regal expanded seat	2
6	33-02-0007	5/16" SS Washer	32
7	33-02-0004	7/16" SS Washer	9
8	33-02-0008	3/8" Flat Washer (SS)	4
9	33-05-0029	5/16" x 1" Machine Bolt (SS)	16
10	33-06-0050	7/16" x 5-1/2" Machine Bolt	4
11	33-03-0012	5/16" Kep Nut (SS)	16
12	33-01-0006	7/16" Hex Nut (SS)	4
13	33-01-0018	3/8" Hex Nut (SS)	4
14	33-06-0067	3/8" x 4" Carriage Bolt (Zinc)	4

Required Surface Mount Hardware:
 3/8" x 3-1/2" Concrete Expansion Anchor Bolts
 (Not Included)

Superior[®]
 RECREATIONAL PRODUCTS
A PLAYCORE Company

STEP 1

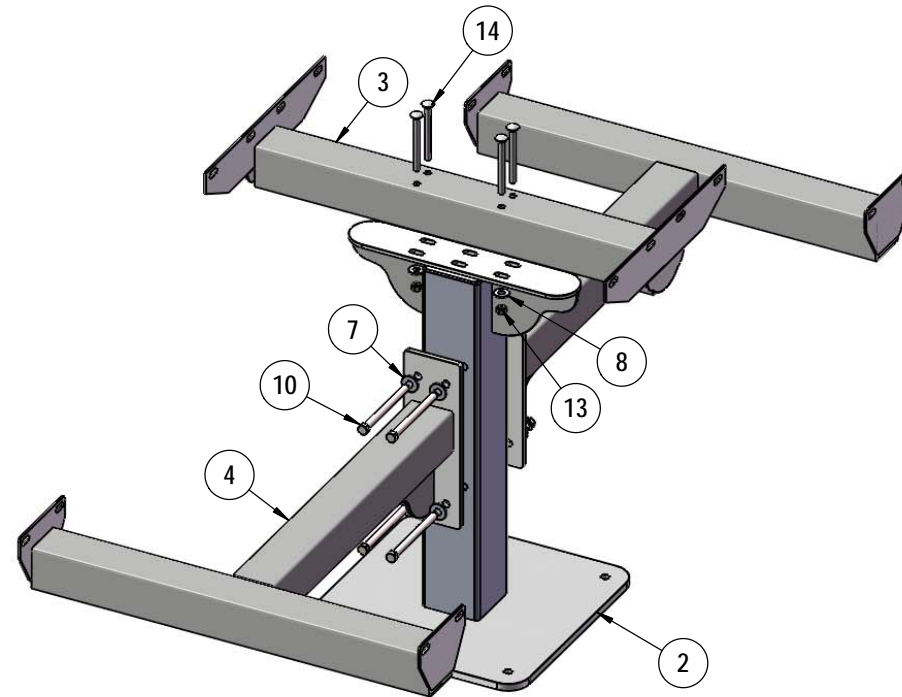

Attach the top bracket assembly and the seat arm assemblies to the post as shown using specified hardware.

STEP 2

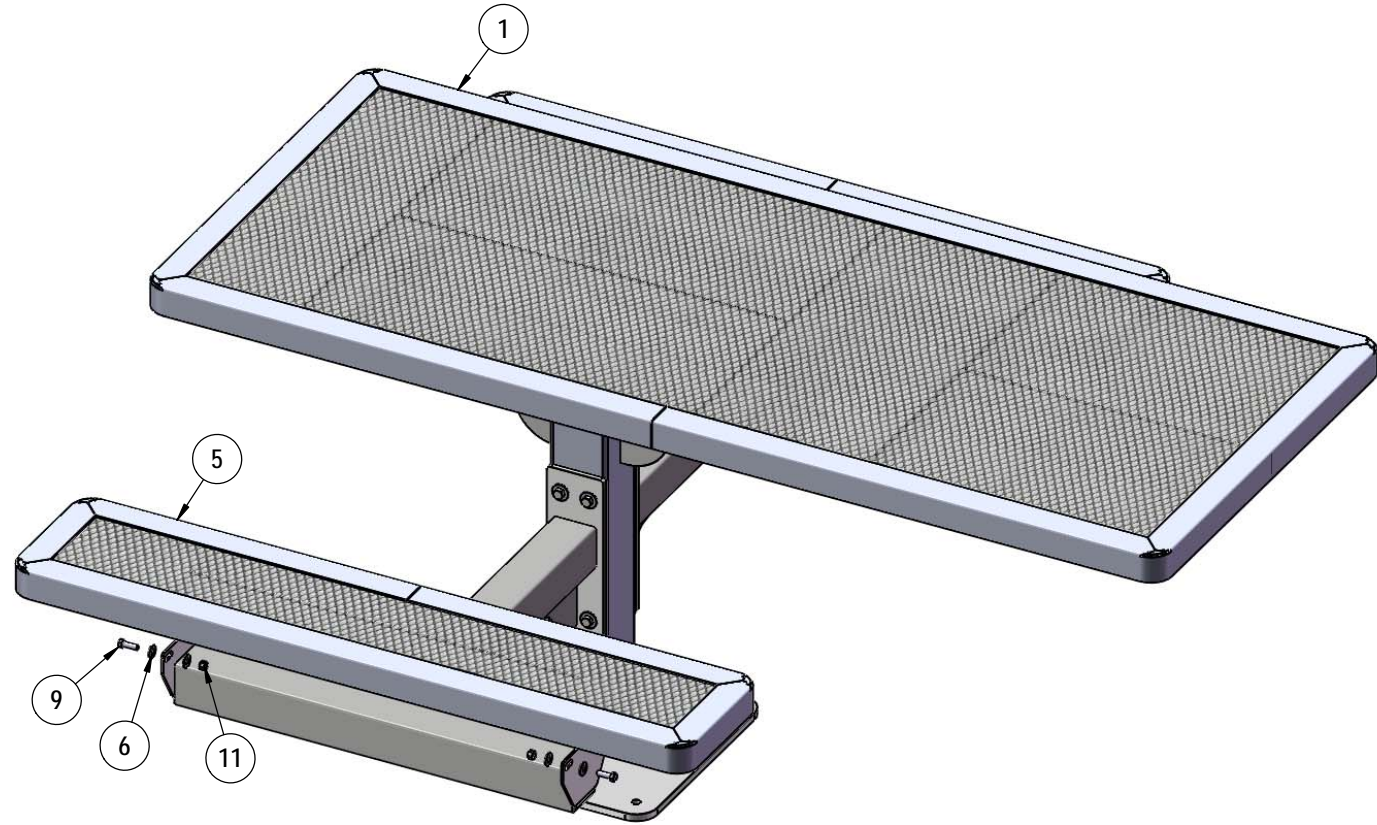

Attach the top and seats to the top and seat bracket assemblies as shown using specified hardware.

OVERALL DIMENSIONS

