

TITAN

MULTIGYM

With no moving parts, the TITAN bodyweight multigym is completely tamperproof and was specifically designed for safety and security.

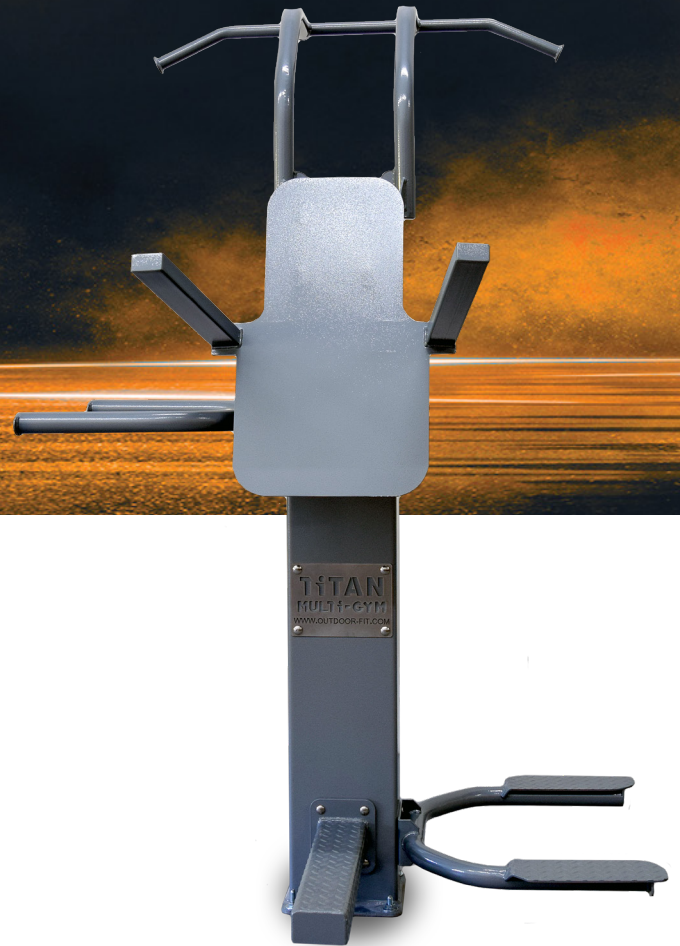

The Quality of Commercial Gym Fitness Equipment

The TITAN outdoor fitness multigym takes the basics of indoor commercial fitness equipment and delivers it to the outside world in a tamperproof, durable, and weatherproof package.

Compact, cost effective, and completely safe, the TITAN is designed for any fitness level or ability.

 **TAMPERPROOF.**  **WEATHERPROOF.**  **SAFE.**

COMPLETELY TAMPERPROOF

The TITAN has no moving parts, eliminating pinch points and entrapment areas. The TITAN's completely tamperproof design also means nothing can be removed from the unit.

5 DIFFERENT EXERCISES

The TITAN is designed with five different exercises, offering a full body workout. Its multigym design allows users to move around the equipment in a circuit training format.

4 SIMULTANEOUS USERS

The TITAN helps you make the most of your space, with up to four people using the equipment at once.

The TITAN is built to maximize indoor or outdoor exercise areas, with 5 exercises available:

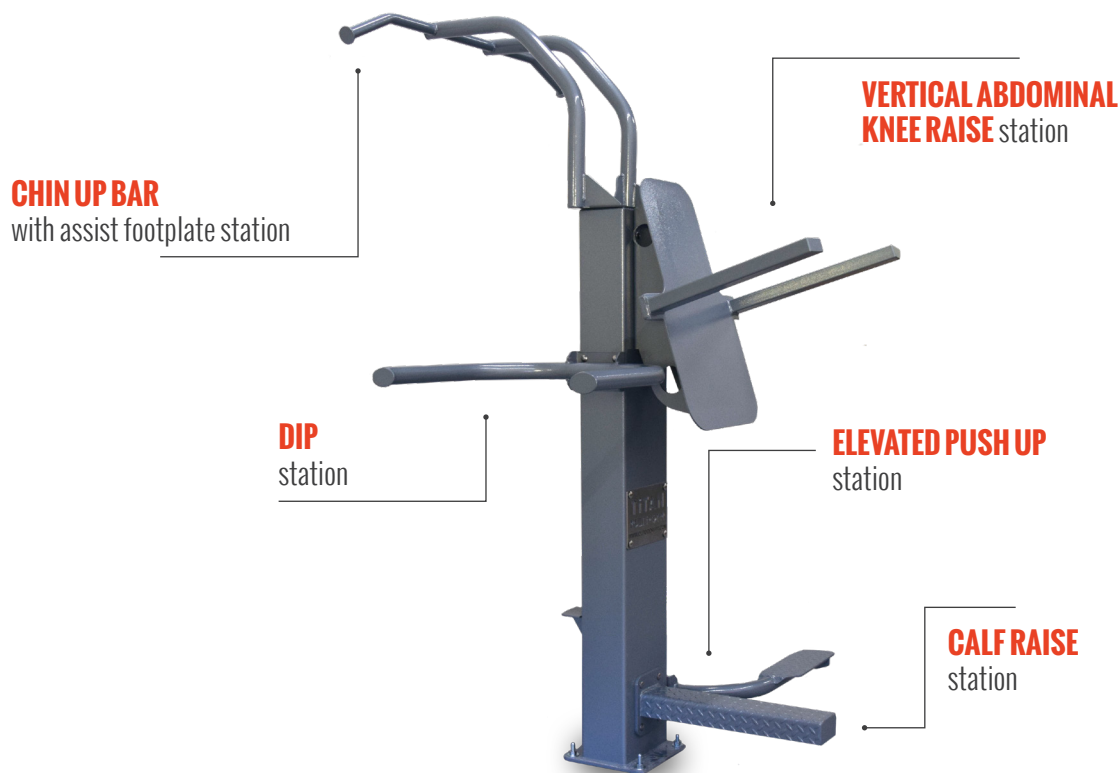

TECHNICAL SPECIFICATIONS



Width: 54" / 138 cm

Length: 57" / 145 cm

Height: 85" / 216 cm

Weight: 253 lbs / 115 kg



Anchoring Requirements: 4 x concrete anchors with rated "pull out" or "tension" strength of 3400lbs or greater. Anchors must be secured into structural concrete.

Frame & Finish: Constructed of 3/16" and 1/4" heavy duty steel that is zinc primed and polyester powder coated with UV stabilized color pigment. All fasteners are tamperproof stainless steel carriage bolts with the locking nuts on the inside of the padlocked center columns.

Standard Color: Silver Hammertone. Custom colors available for an extra charge.

Shipping Weight: 358 lbs / 163 kg

Shipping Dimensions: 48" wide x 60" long x 30" high / 122 cm wide x 153 cm long x 77 cm high

Number of Simultaneous Users: 4

CAD DRAWING

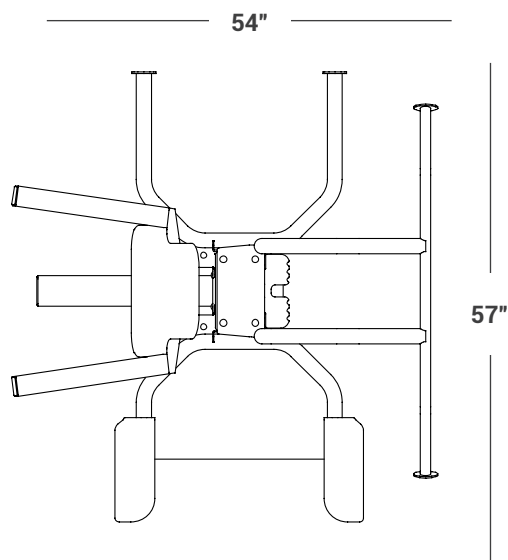

TITAN
MULTIGYM