

# Installer's Reference

UC-12-400-R0-012620











## Adjustable Jump

### Know What's Below

As with all projects involving digging, start by knowing what is in the ground below. Underground utilities may include cable, electric, sprinklers, sewer, water, telecommunications, drainage pipes and sprinklers. You can usually accomplish this with one phone call (Dial 811) to your state's underground utility service.

### Conduct an Inventory

Begin installation with of hardware and parts, assuring everything you need is onsite when you begin.

| ITEM   | NO. | ITEMS NAME  | PICT  | COLOR         | QTYS | PKGS | SET |
|--|-----|---|---|---------------|------|------|-----|
|  <p>(Assembled Unit)</p> | 1   | Verticle Post   |    | Blue OR Green | 2    | PCS  | 3   |
|  | 2   | Adjustable Brackets/ Jump Bar   |   | Blue OR Green | 3    | PCS  |     |
|  | 3   | PE Bones  |  | Tan           | 2    | PCS  |     |
| HARDWARE   | 1   |  TAMPER PROOF TORX-BOLT M10x30 |   |               | 4    | PCS  | 1   |
|  | 2   |  FLAT WASHER M10               |   |               | 8    | PCS  |     |
|  | 3   |  LOCK NUT M10                  |   |               | 4    | PCS  |     |
|  | 4   |  TAMPER TORX-BOLT M8x35        |   |               | 6    | PCS  |     |
|  | 5   |  LOCK WASHER M8                |   |               | 6    | PCS  |     |
|  | 6   |  FLAT WASHER M8                |   |               | 6    | PCS  |     |

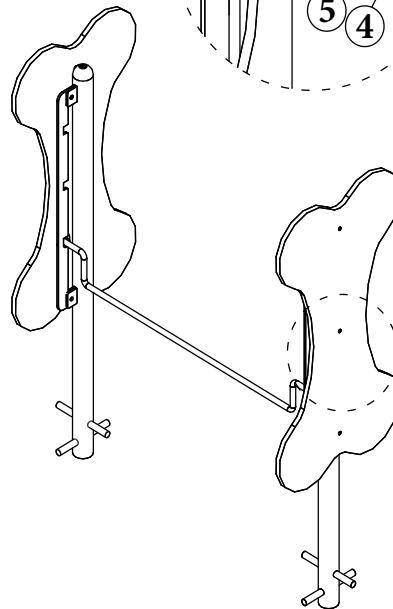
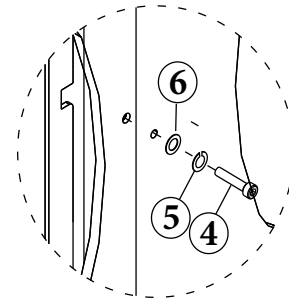
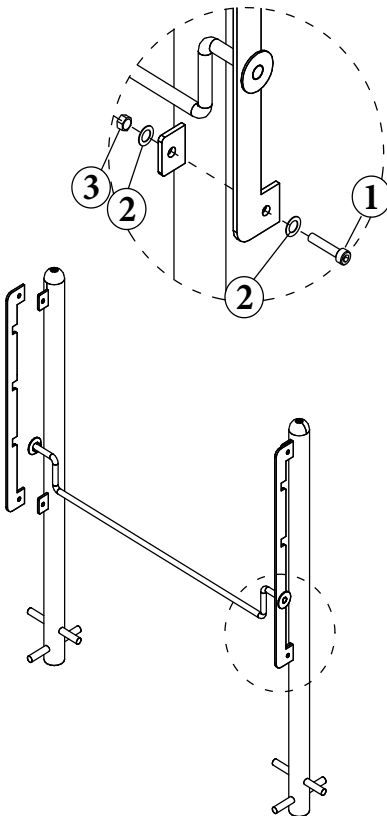
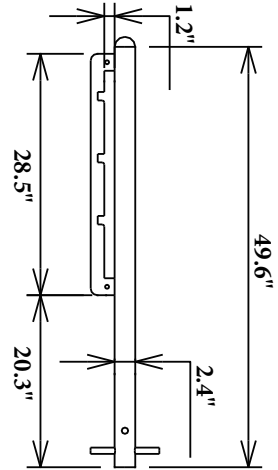
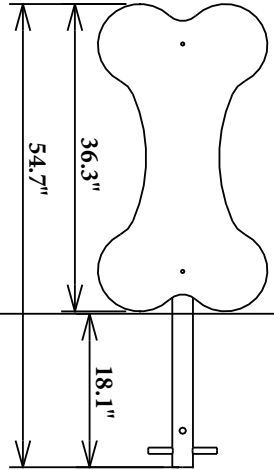
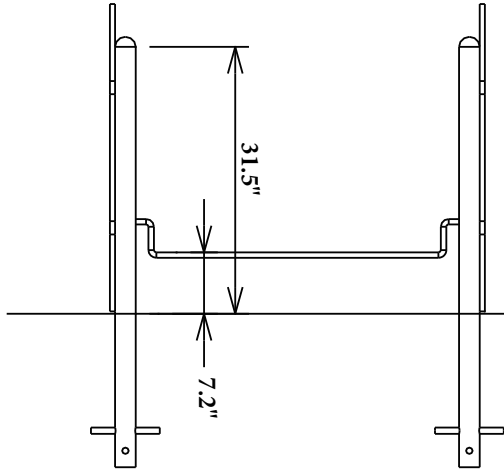
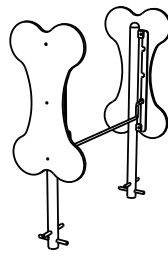
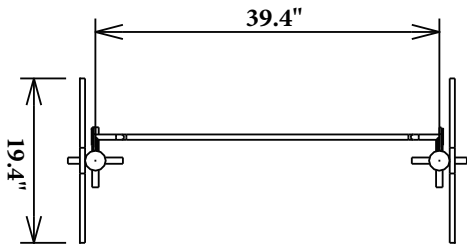

**JUMP ASSEMBLY**

- 1. TAMPER RESISTANT TORX-BOLT, M10x30 (4)
- 2. FLAT WASHER, M10 (8)
- 3. LOCK NUT, M10 (4)

**BONE FACING**

- 4. TAMPER RESISTANT TORX-BOLT, M8x35 (6)
- 5. LOCK WASHER, M8 (6)
- 6. FLAT WASHER, M8 (6)