

Advocate™

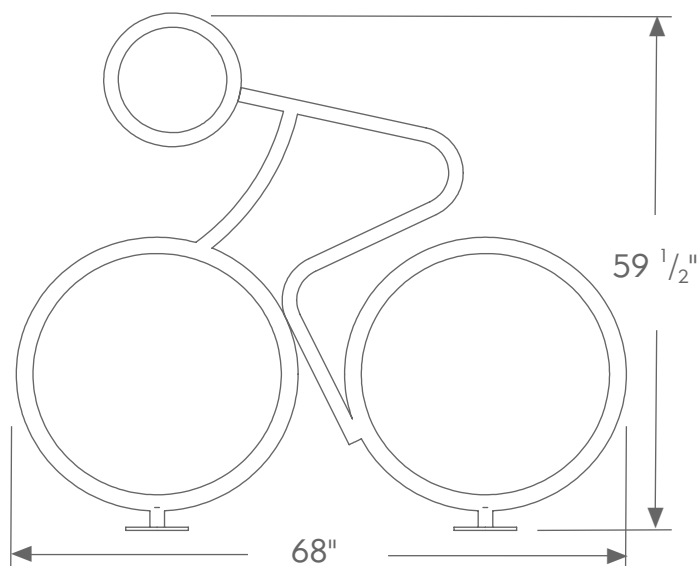

The Madrax Advocate Bicycle Rack is a creative bike rack that was inspired by the old Bike Federation's logo. The Advocate bike rack offers a whimsical touch to bike parking solutions. The Advocate is constructed of 1-7/8" and 1-5/8" OD structural steel tubing & is available with Galvanized, Powder Coated, or Powder Coated Stainless Steel finishes.

Item #: ADB - 4 - _____ - _____
MOUNT FINISH



Galvanized

Withstanding the elements with little to no maintenance, our galvanized products are durable and weather to a battleship grey. For this finish, the product will have vent holes that will allow draining after a hot-dip in the molten zinc tank. A galvanized product is an economical choice that resists rust. This finish comes with a 5-year warranty.

Powder Coated Stainless Steel

Constructed with stainless steel, Powder Coated Stainless Steel racks are highly durable due to the anti-corrosive property of the steel used in construction. Racks are polished and then coated with an electrostatically applied super TGIC polyester powder. These products come with a 5-year warranty.

Super TGIC Powder Coat

Available in 18 vibrant shades, super TGIC coated products will stain significantly less from UV light than other finishes. This finish has a 1-year warranty.



Note: Due to variations in the printing process, colors shown may not be an exact match. Please request color samples from Madrax for accurate color comparisons.