

# Ashton Shelter™

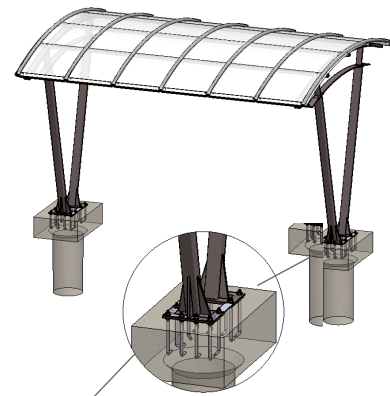

The Ashton Bike Shelter provides cyclists with covered bike parking to protect against the elements. This bike shelter is compatible with a large variety of bicycle racks. Ashton Bike Shelters have a tough translucent polycarbonate roof top that is 20 times stronger than fiber glass tops and has all-welded steel construction for ease of installation. This bike shelter is an unmatched dramatic, high-quality, hand-crafted shelter that will enhance your outdoor space.



DETAIL OF OPTIONAL FOOTING DESIGN

# Ashton Shelter™

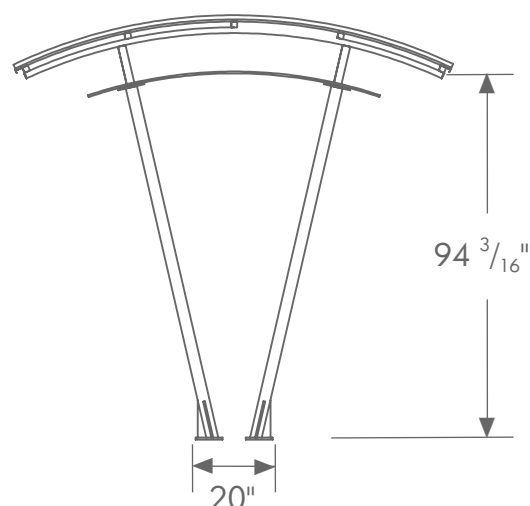
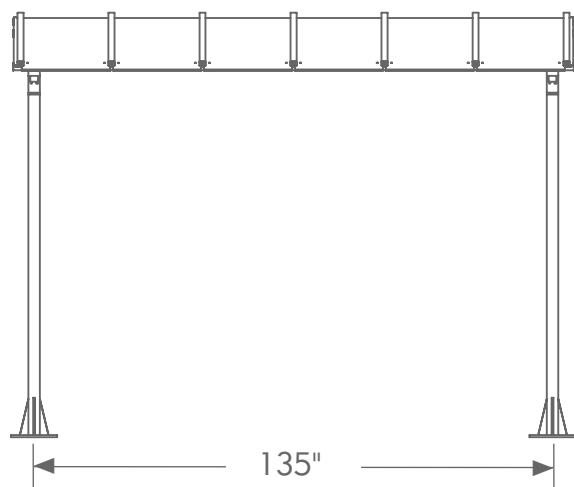

## Galvanized

Withstanding the elements with little to no maintenance, our galvanized products are durable and weather to a battleship grey. For this finish, the product will have vent holes that will allow draining after a hot-dip in the molten zinc tank. A galvanized product is an economical choice that resists rust. This finish comes with a 5-year warranty.

## Super TGIC Powder Coat

Available in 18 vibrant shades, super TGIC coated products will stain significantly less from UV light than other finishes. This finish has a 1-year warranty.



Note: Due to variations in the printing process, colors shown may not be an exact match. Please request color samples from Madrax for accurate color comparisons.