



DERO
A PLAYCORE Company



Meter Hitch

Based on our popular Bike Hitch, the Meter Hitch is designed to fit into the streetscape. The Meter Hitch has a minimal footprint and is a bicyclist favorite for its ease of use and solid bike support. Planners also appreciate that design restricts bikes to parking parallel with the rack so bikes will not interfere with pedestrian right of way or the street.

Patent D620,8455

Meter Hitch



FINISH OPTIONS

Galvanized



Stainless



Powder Coat



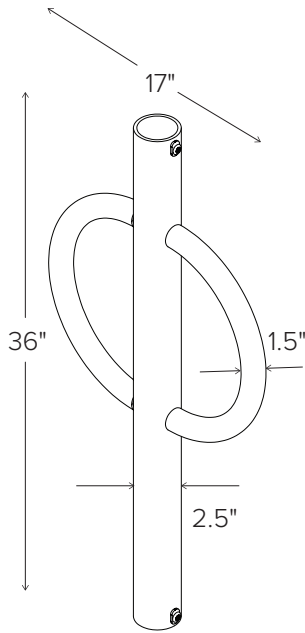

CAPACITY 2 Bikes

MATERIALS **Centerbeam:** 2.5" schedule 40 pipe

All Meter Hitches are made based on existing pole dimension to be provided by customer. Please verify all post dimensions with Dero before ordering.

FINISHES

- Galvanized**
An after fabrication hot dipped galvanized finish is our standard option.
- Powder Coat**
Our powder coat finish assures a high level of adhesion and durability by following these steps:
 1. Sandblast
 2. Epoxy primer electrostatically applied
 3. Final thick TGIC polyester powder coat
- Stainless**
Stainless Steel: 304 grade stainless steel material finished in either a high polished shine or a satin finish.

MOUNT OPTIONS

Hitch Mount
Meter Hitch slides over existing 2.38" OD parking meter poles. Two tamper-resistant set screws secure the Meter Hitch to the parking meter pole.

- CAP**
- Capped** (if no meter will remain on the pole)
 - Uncapped** (if meter will remain on the pole)

